

# INSTRUCTION MANUAL

Serial Number 567

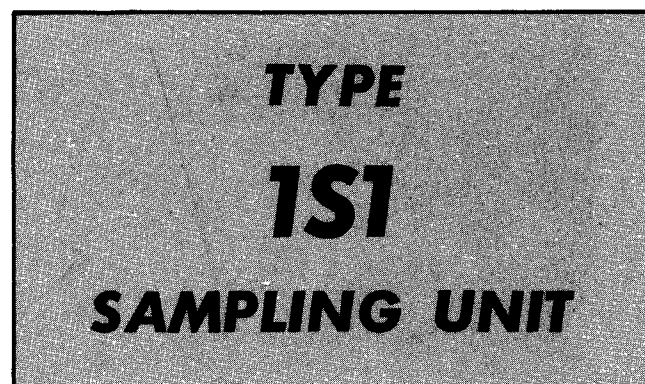

Tektronix, Inc.

S.W. Millikan Way • P. O. Box 500 • Beaverton, Oregon • Phone MI 4-0161 • Cables: Tektronix

070-0475-00

765



## WARRANTY

All Tektronix instruments are warranted against defective materials and workmanship for one year. Tektronix transformers, manufactured in our own plant, are warranted for the life of the instrument.

Any questions with respect to the warranty mentioned above should be taken up with your Tektronix Field Engineer.

Tektronix repair and replacement-part service is geared directly to the field, therefore all requests for repairs and replacement parts should be directed to the Tektronix Field Office or Representative in your area. This procedure will assure you the fastest possible service. Please include the instrument Type and Serial number with all requests for parts or service.

Specifications and price change privileges reserved.

Copyright © 1965 by Tektronix, Inc., Beaverton, Oregon. Printed in the United States of America. All rights reserved. Contents of this publication may not be reproduced in any form without permission of the copyright owner.



## CONTENTS

Warranty

- Section 1 Characteristics
- Section 2 Operating Instructions
- Section 3 Circuit Description
- Section 4 Maintenance
- Section 5 Calibration
- Section 6 Parts List and Diagrams

A list of abbreviations and symbols used in this manual will be found on page 6-1. Change information, if any, is located at the rear of the manual.

# TYPE 1S1 SAMPLING UNIT

RISETIME  $\leq .36$  nSEC

**TIME POSITION FINE** (KNOB)

**VERT POSITION DC OFFSET  $\pm 1V$**  (KNOB)

**m VOLTS/CM** (CAL VARIABLE) (KNOB)  
Scale: 100, 200, 50, 20, 10, 5, 2

**VERT GAIN** (KNOB)

**VAR BAL** (KNOB)

**TIME/CM** (CAL VARIABLE) (KNOB)  
Scale: 5  $\mu$ S, 1, 50, 20, 10, 5, 2, 500 nS

**SMOOTHING SAMPLES/CM** (KNOB)  
Scale: MIN, NORM, 50  $\mu$ S

**TRIGGER SENSITIVITY RECOVERY TIME** (KNOB)  
Scale: 50 nS, SYNC

**DISPLAY MODE** (KNOB)  
Options: MANUAL SCAN, EXT HORIZ ATTEN, NORMAL, SINGLE SWEEP, MAN

**TRIGGER SOURCE** (KNOB)  
Options: EXT, INT, FREE RUN

**MAGNIFIER** (KNOB)  
Scale: 1, 2, 5, 10, 20, 50  
Label: PULL TO UNLOCK

**EXT TRIG** (KNOB)

**PROBE POWER** (KNOB)

**SIGNAL IN  $\pm 2V$  MAX,  $50\Omega$**  (BNC)

**EXT TRIG  $\pm 2V$  MAX,  $50\Omega$**  (BNC)

**OFFSET OUTPUT** (BNC)

**EXT HORIZ INPUT** (BNC)

**VERT OUTPUT** (BNC)

**HORIZ OUTPUT** (BNC)

**Specifications:**  
X10, 10K $\Omega$  VERT OUTPUT  
150V MAX HORIZ OUTPUT  
2V/CM, 10K $\Omega$  VERT OUTPUT  
1V/CM, 10K $\Omega$  HORIZ OUTPUT

**SERIAL** [ ]

**TEKTRONIX, INC., PORTLAND, OREGON, U.S.A.**

Type 151 Sampling Unit



# SECTION 1

## CHARACTERISTICS

### GENERAL DESCRIPTION

The Tektronix Type 1S1 Sampling Unit is a combination vertical- and horizontal-deflection plug-in unit for use with any Tektronix oscilloscope that accepts 1-series or letter-series plug-in units. The Type 1S1/Oscilloscope combination forms a complete sampling system with a risetime of 350 picoseconds or less and an equivalent bandpass to at least 1 gigacycle. The crt display is produced by reconstructing the signal waveform from a series of samples taken from many repetitions of the input signal.

Calibrated equivalent-time sweep rates provide accurate crt displays from 50  $\mu\text{sec}/\text{cm}$  to 100 psec/cm. A tunnel diode trigger circuit provides triggering from 10 cps to 1 Gc or more from either an internal or external signal on either the positive-going or negative-going slope. (Pulse triggering is required below 100 kc.) An internal signal delay line permits the observation of fast-rise pulses without the need of external signal delay. Time-positioning of the signal on the crt screen is provided by a front-panel control.

Display dot density is continuously variable from approximately 5 samples/cm to several thousand samples/cm. A direct-reading time magnifier permits equivalent sweep magnification of up to X100 with no change in display dot density. Magnification takes place about a time-reference point that remains fixed at the left edge of the screen. The equivalent sweep rate is always read directly from the single TIME/CM switch setting, even when the display is magnified. Internal circuitry provides blanking between displayed dots as well as during sweep retrace. Display noise is 1 mv or less and may be reduced by "smoothing."

Real-time sampling technique can also be used with the Type 1S1 for viewing low-frequency signals. In this type of operation, the input signal is sampled by the Type 1S1, and the display oscilloscope real-time sweep and triggering are utilized. (See the Operating Instructions for use of the real-time sampling technique.)

The following characteristics indicated by footnote (1) apply over an ambient temperature range of 0° C to +50° C. Warm-up time for the given accuracy is 20 minutes.

### VERTICAL SYSTEM

#### Risetime

350 psec or less, measured between the 10% and 90% amplitude levels.<sup>1</sup>

#### Bandpass

Equivalent to dc to 1 Gc.

#### Deflection Factors

Calibrated steps of 2, 5, 10, 20, 50, 100 and 200 mv/cm, selected with the front-panel mVOLTS/CM switch. Accuracy

is within 3% at all switch positions<sup>1</sup> with the VARIABLE control in CAL position and an input signal source impedance of 50 ohms.

The VARIABLE control provides uncalibrated deflection factors between steps of the mVOLTS/CM switch, increasing the sensitivity up to 4 times or more from the calibrated position.<sup>1</sup> At the 2 position of the mVOLTS/CM switch, the VARIABLE control extends the deflection factor to at least 0.5 mv/cm.

#### Input Coupling

Dc-coupled from 50-ohm SIGNAL IN connector to sampling bridge.

#### Input Impedance

Nominally 50 ohms at SIGNAL IN connector. A higher input impedance to the sampling system may be obtained through the use of a passive sampling probe or a cathode-follower probe.

#### Internal Delay Line

Signal delay between trigger takeoff and sampling gate permits crt display to start approximately 4 nsec in advance of the triggering point on the waveform.

#### Input Signal Requirements

Dynamic operating range is  $\pm 2$  volts. Frequencies (or repetition rates) from dc to 1 Gc or more.

#### Maximum Signal Input Voltage

Allowable accidental short-time overload is  $\pm 5$  volts.

#### Display Noise

1 mv or less, peak to peak, with the SMOOTHING control set for normal response (unity loop gain).<sup>1</sup>

#### Low-Frequency Tilt

3% or less following leading edge of square wave, at 150 kc or less.<sup>1</sup>

#### Memory Drift

No visible dot drift at triggering rates above approximately 50 cps; 1 cm or less of vertical drift at 10 cps triggering rate.<sup>1</sup>

<sup>1</sup>Performance requirement checked at the factory.

## Smoothing Control Range

At least 3:1 reduction of display noise (compared to noise present at normal-response position) with front-panel SMOOTHING control set fully counterclockwise.<sup>1</sup> If the display dot density is low, smoothing reduces dot transient response of the system.

## Interdot Blanking

Internally coupled through oscilloscope chopped blanking circuit, with CRT Cathode Selector switch at Chopped Blanking position.

## Retrace Blanking

Off-screen retrace, produced by signal applied internally through vertical channel.

## Trigger Takeoff Signal

Signal amplitude to trigger circuit is approximately 1/7th the amplitude of the vertical input signal.

## DC Offset

At least +1 volt to -1 volt offset range, obtained through use of the front-panel DC OFFSET control.<sup>1</sup> Permits use of full sensitivity even in the presence of dc levels up to  $\pm 1$  volt.

## Vertical Position Control Range

At least 10 cm positioning capability on the crt screen.<sup>1</sup>

## Offset Output

At least +10 volts to -10 volts offset monitor range. Voltage change at the front-panel OFFSET OUTPUT jack is 10 times the voltage change ( $\pm 2\%$ ) of the display produced by use of the DC OFFSET control.<sup>1</sup> Output voltage permits accurate measurement of dc voltage level changes.

## Front-Panel Vertical Output

200 mv amplitude ( $\pm 3\%$ ) per cm of crt display, into a high-impedance load.<sup>1</sup> Output signal is the real-time waveform of the sampled signal displayed on the crt screen.

## HORIZONTAL SYSTEM

### Display Modes

Repetitive, single-sweep, manual scan or external horizontal scan, selected by the front-panel DISPLAY MODE switch. In SINGLE SWEEP position, the START button starts a single sweep of the display.<sup>1</sup>

### Equivalent Sweep Rates

50  $\mu$ sec/cm through 1 nsec/cm, unmagnified, in 15 calibrated steps. Sequence is 1, 2, 5. A direct-reading magnifier

provides up to X100 magnification (depending on the sweep rate) with no change in dot density. Magnification takes place about the left edge of the screen. Using the magnifier, the fastest calibrated sweep rate is 100 psec/cm.

An uncalibrated Time/Cm VARIABLE control provides sweep rates between the calibrated steps, increasing the sweep speed up to at least 3 times the calibrated speed<sup>1</sup>, and extending the fastest magnified rate to about 33 psec/cm.

### Equivalent Sweep Rate Accuracy

Within 3% of the rate indicated by the TIME/CM switch (with the VARIABLE control at CAL), excluding the first portion of each time position ramp when the oscilloscope deflection factor is set to 1 volt/cm  $\pm 1\%$ .<sup>1</sup> The portion excluded (with the TIME POSITION and FINE controls fully clockwise) is 2% of the total ramp on the 500  $\mu$ S, 50  $\mu$ S and 5  $\mu$ S ranges and 4% of the total ramp on the 50 nS range.

### Display Time Positioning

50 nsec to 500  $\mu$ sec time-positioning capability, depending on the equivalent sweep rate and magnification. TIME POSITION and FINE controls delay the start of the display time window over the approximate range indicated by the blue tab on the TIME POSITION RANGE switch, as read on the blue Time Position Range scale. Total duration of observable display time is equal to the TIME POSITION RANGE setting plus the time width of the crt screen.

### Display Samples/Cm

Continuously variable from approximately 5 samples/cm to more than 7,000 samples/cm.<sup>1</sup> Sweep may progress perceptibly when the control is switched to SWEEP OFF position.

### Front-Panel Horizontal Output

1 volt/cm of horizontal display ( $\pm 1\%$ ) when the horizontal deflection factor of the oscilloscope is adjusted correctly.<sup>1</sup>

### External Horizontal Deflection Factor

1 volt/cm  $\pm 4\%$  with the EXT HORIZ ATTEN control turned fully clockwise.<sup>1</sup>

16 volts (or more)/cm with the EXT HORIZ ATTEN control turned fully counterclockwise.<sup>1</sup>

### Display Jitter

0.02% or less of the 500  $\mu$ S, 50  $\mu$ S or 5  $\mu$ S time position ranges.<sup>1</sup>

0.024% or less of the 500 nS time position range.<sup>1</sup>

0.08% or less of the 50 nS time position range.<sup>1</sup>

These values apply when using a 400-mv to 1-volt triggering signal with a fast rise (relative to the minimum amount of triggering jitter).

<sup>1</sup> Performance requirement checked at the factory.

### Triggering Source

Internal from trigger takeoff at input of vertical channel, or external from front-panel 50-ohm EXT TRIG input connector. Both triggering sources are disconnected in FREE RUN position of the TRIGGER SOURCE switch.

### Input Impedance

Nominally 50 ohms at EXT TRIG connector.

### Trigger Coupling

Ac-coupled from both internal and external sources.

### Trigger Slope

Positive-going (+) or negative-going (−) from either internal or external triggering source as selected by the TRIGGER SOURCE switch.

### Sine-Wave Triggering Requirements

Frequency—100 kc or less to 1 Gc or more.<sup>1</sup>

Amplitude—50 mv or less to 2 volts peak to peak (at SIGNAL IN connector) for internal triggering; 8 mv or less<sup>2</sup> to 200 mv peak to peak (at EXT TRIG connector) for external triggering.

### Fast-Rise Triggering Requirements

Repetition Rate—Approximately 10 cps to 1 Gc. Below 50 cps the display may be limited by memory drift.

Amplitude— $\pm 40$  mv to  $\pm 2$  volts (at SIGNAL IN connector for internal triggering;  $\pm 7$  mv to  $\pm 200$  mv (at EXT TRIG connector) for external triggering.

### Maximum External Triggering Voltage

Allowable accidental short-time overload of  $\pm 2$  volts.

### Trigger Recovery Time

11.5  $\mu$ sec  $\pm 1.5$   $\mu$ sec on 50 nS or 500 nS time position range.<sup>1</sup>

23.5  $\mu$ sec  $\pm 3.5$   $\mu$ sec on 5  $\mu$ S time position range.<sup>1</sup>

235  $\mu$ sec  $\pm 35$   $\mu$ sec on 50  $\mu$ S time position range.<sup>1</sup>

2.05 msec  $\pm 0.25$  nsec on 500  $\mu$ S time position range.<sup>1</sup>

These values apply only when the RECOVERY TIME control is set to minimum position (fully counterclockwise but not at SYNC). The trigger recovery time is increased by turning the RECOVERY TIME control clockwise.

### Triggering Jitter (Low-Amplitude)

200 psec or less on a 2-nsec duration pulse of 40-mv amplitude for internal triggering or 7-mv amplitude for external triggering.<sup>1</sup>

200 psec or less on a 1-Gc sine-wave of 50-mv amplitude for internal triggering or 8-mv amplitude for external triggering.<sup>1</sup>

5 nsec or less on a 10-Mc sine wave of 50-mv amplitude for internal triggering or 8-mv amplitude for external triggering.<sup>1</sup>

0.7  $\mu$ sec or less on a 100-kc sine wave of 50-mv amplitude for internal triggering.<sup>1</sup>

0.5  $\mu$ sec or less on a 100-kc sine wave of 4-mv amplitude for external triggering.<sup>1</sup>

Amplitude for internal triggering is that at the SIGNAL IN connector; amplitude for external triggering is that at the EXT TRIG connector.

### External Trigger Kickout

25 mv or less at the EXT TRIG connector with the TRIGGER SOURCE switch at  $\pm$ EXT.<sup>1</sup>

## POWER SUPPLY

### Regulated Voltages

Regulated supplies provide  $-19$ -volt and  $+19$ -volt outputs for stable operation of the sampling circuits.

### Probe Power

Power provided through front-panel connector for operation of cathode-follower probe. Filament voltage is approximately  $-12.6$  volts (terminal B) when loaded and plate voltage is approximately  $+100$  volts (terminal D).

## ENVIRONMENTAL CHARACTERISTICS

### Temperature

Operating— $0^{\circ}$  C to  $+50^{\circ}$  C.

Non-operating— $-40^{\circ}$  C to  $+65^{\circ}$  C.

### Altitude

Operating—15,000 feet maximum.

Non-Operating—50,000 feet maximum.

## MECHANICAL CHARACTERISTICS

### Ventilation

Forced filtered air is provided by the display oscilloscope.

### Construction

Aluminum-alloy chassis frame and anodized front panel. Epoxy-laminate etched-wiring boards.

### Dimensions

Height—7 inches; width— $5\frac{7}{8}$  inches; depth— $11\frac{1}{2}$  inches.

<sup>1</sup> Performance requirement checked at the factory.

## Characteristics—Type 151

### Weight

Approximately 8 pounds.

### STANDARD ACCESSORIES

2—50  $\Omega$  10X T-attenuators with GR connectors (017-0044-00)

1—10-nsec 50  $\Omega$  coax cable (RG-58A/U) with GR connectors (017-0501-00).

1—5-nsec 50  $\Omega$  coax cable (RG-8A/U) with GR connectors (017-0502-00).

1—18-inch patch cord (red) with banana combination connectors (012-0039-00)

1—GR-to-BNC plug connector adapter (017-0064-00).

1—GR-to-BNC jack connector adapter (017-0063-00).

2—Instruction Manuals (070-0475-00).

# SECTION 2

## OPERATING INSTRUCTIONS

### General Information

This section of the manual provides the basic information required for operation of the Type 1S1. Instructions are included for installing the unit, using the front-panel controls, setting up the crt display, triggering the display and using the Type 1S1 for making voltage and time measurements.

The Type 1S1 operates with the indicator oscilloscope to form a complete sampling system, capable of viewing repetitive waveforms with risetimes in the sub-nanosecond range or frequencies up to more than one gigacycle. The "equivalent-time" display is formed by taking samples from many cycles of the waveform and reconstructing the waveform on the crt screen. A bright crt display is produced, since each displayed dot is momentarily stationary, and the display repetition rate may be varied over a wide range by changing the number of dots in the display. For a triggered display, each dot requires a separate triggering event, rather than one trigger per sweep as in a conventional real-time display.

### Installation

To install the Type 1S1 in the oscilloscope, insert it into the plug-in compartment and push it in as far as it will go. Secure the unit by turning the securing-rod knob (at the bottom of the front panel) clockwise until it is tight. The horizontal deflection patch cord is then connected, as described later under "First-Time Operation."

To remove the unit, disconnect the patch cord, then turn the securing-rod knob counterclockwise until the rod feels loose. Pull the Type 1S1 part of the way out of the compartment with the knob, then take hold of the unit by the corner rods to remove it from the oscilloscope.

The Type 1S1 may be removed or inserted without turning off the oscilloscope power; however, it is recommended that the power be turned off to protect the unit from transient voltage surges that might occur as the various interconnecting plug terminals make or break contact. If the power is left on, be sure to turn down the crt beam intensity.

Whenever the Type 1S1 is transferred from one oscilloscope to another, the horizontal deflection factor of the oscilloscope must be adjusted and the "Operational Adjustments" described later in this section should be checked. These operational adjustment controls can all be reached either from the front panel or from the left side of the unit after removing the oscilloscope left side panel (or after extending a rack-mounted oscilloscope). If the oscilloscope is operating properly, the Type 1S1 should remain within the operating specifications given in Section 1.

For checking circuits or for adjusting horizontal circuit controls, the Type 1S1 can be operated on either a rigid extension or a flexible extension cable. For normal operation, however, the unit should be installed directly in the oscilloscope.

### Cooling

The fan in the display oscilloscope provides forced-air cooling of the Type 1S1. For proper circulation of air, the oscilloscope should normally be operated with the side panels in place. A constant temperature is important for accurate operation of the instrument. Ambient air temperature should not exceed 50° C (122° F).

### FRONT-PANEL CONTROLS

All controls and connectors required for the normal operation of the Type 1S1 are located on the front panel of the unit (see Fig. 2-1). To make full use of the capabilities of the instrument, the operator should be familiar with the function and use of each of these controls and connectors. Brief descriptions are presented in Table 2-1 and further information, if necessary, is included later in this section under an appropriate heading. The nature of the input signal and the triggering signal will determine the setting of the controls.

**TABLE 2-1**

Functions of Controls and Connectors

VERTICAL	
mVOLTS/CM Switch	Selects vertical input deflection factor from 7 calibrated steps ranging from 200 mv/cm to 2 mv/cm. Deflection factor is calibrated only when mVolts/Cm VARIABLE control is at CAL position and VERT GAIN adjustment is set correctly.
mVolts/Cm VARIABLE Control	Varies vertical input deflection for adjusting display amplitude between steps of mVOLTS/CM switch. Extends deflection factor to about 500 $\mu$ v/cm from 2 mv/cm position of switch. When making voltage measurements from display, be sure VARIABLE control is set to CAL position. Does not affect dc offset voltage measurement.
VERT POSITION Control	Positions display vertically on oscilloscope crt screen. Positioning range is slightly greater than 10 cm. Further vertical positioning is provided by DC OFFSET control.
DC OFFSET Control	Positions display vertically on oscilloscope crt screen by adding internal dc voltage (+1 volt to -1 volt) to vertical signal. Amount of offset voltage added to signal (multiplied $\times 10$ ) can be accurately monitored at OFFSET OUTPUT jack.
OFFSET OUTPUT Jack	Provides monitor output for determining amount of offset voltage added by DC OFFSET control. Voltage change at OFFSET OUTPUT jack is 10 times the vertical signal dc level change produced by DC OFFSET control. Output impedance is

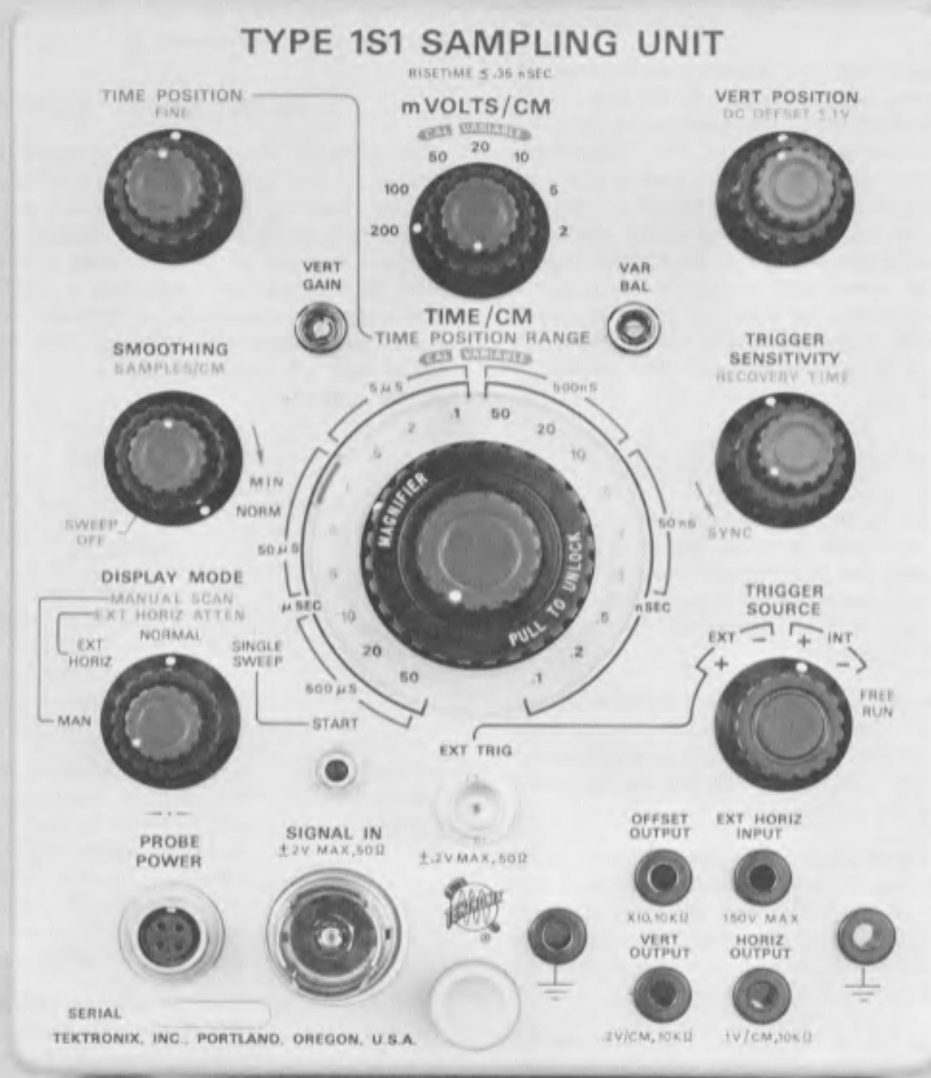

Fig. 2-1. Front-panel controls and connectors.

10 k ohms. Measurement of offset voltage should be made with high-impedance device.

**SMOOTHING Control** Reduces random display noise amplitude when control is turned counterclockwise. Noise may be decreased to approximately 1/3rd of the value present at normal response position (NORM). If display dot density is low, smoothing reduces apparent transient response of system.

**PROBE POWER Connector** Provides filament and plate voltages and ground return for operation of cathode-follower probe.

**SIGNAL IN Connector** Provides 50-ohm environment for applying signal to input circuit of vertical system. Connector is followed by trigger takeoff, delay line, 50-ohm termination and sampling gate. Dynamic operating range is up to  $\pm 2$  volts and maximum short-time overload is approximately  $\pm 5$  volts (higher with reduced duty factor).

**VERT OUTPUT Jack** Provides real-time replica of signal applied to oscilloscope vertical amplifier. Output amplitude (through 10 k ohms) is 200 mv per cm of calibrated display amplitude. Includes dc offset voltage. If vertical signal is driven out of dynamic range of sampling amplifiers, signal at VERT OUTPUT jack is distorted. Output signal can be used in conjunction with horizontal output to drive pen recorder or monitor oscilloscope.

**VERT GAIN Adjustment** Adjust display amplitude to correspond to deflection factor indicated by mVOLTS/CM switch, when mVolts/Cm VARIABLE control is at CAL position.

**VAR BAL Adjustment** Adjusts vertical balance so that with zero offset voltage trace does not move vertically when mVolts/Cm VARIABLE control is rotated.

**TRIGGERING**

**TRIGGER SENSITIVITY Control** Selects triggering signal level that starts trigger circuit operation. Adjusts frequency of synchronizing circuit for operation on high-frequency triggering signals when RECOVERY TIME control is switched into SYNC position.

**RECOVERY TIME Control and SYNC Switch** Adjusts duration of trigger holdoff interval so that recovery occurs between cycles of input triggering signal, thus providing stable triggering regardless of triggering signal repetition rate. Sets circuit for synchronized operation when control is switched to SYNC detent position at counterclockwise end of rotation.

**TRIGGER SOURCE Switch** Selects triggering signal from vertical channel trigger takeoff or from EXT TRIG input connector. Also selects either positive-going (+) or negative-going (—)

slope of triggering signal. Disconnects triggering signal and permits free run operation of triggering circuit when switch is set to FREE RUN position.

**EXT TRIG Connector**

Permits application of external signal (ac-coupled) for triggering sampling operation. Primarily for use with small amplitude triggering signals (from 5 mv to 200 mv) and for obtaining time positioning not possible with internal triggering. Also permits triggering from a single source to retain time relationships between different vertical input signals and to avoid readjusting triggering controls. One trigger is required for each sample. For slow-rise signals, 1 mv/ $\mu$ sec minimum rate of rise is required. If triggering signal amplitude exceeds 200 mv, be sure to attenuate signal.

**SWEEP**

**TIME/CM (MAGNIFIER) Switch**

Operates with TIME POSITION RANGE indicator to select display equivalent-time sweep rate and time magnification. Calibrated steps range from 50  $\mu$ sec/cm to 0.1 nsec/cm. Time magnification up to X100 is possible on sweep rates from 50  $\mu$ sec/cm to 1 nsec/cm, with no change in display dot density. Magnification takes place following a time-reference point that remains fixed at the left edge of the screen. White dot on MAGNIFIER knob always indicates display equivalent-time sweep rate, even when magnified. Display is calibrated only when Time/Cm VARIABLE control is at CAL position and oscilloscope horizontal deflection factor is adjusted to 1 volt/cm. Display repetition rate also depends on display dot density and on triggering signal repetition rate.

**Time/Cm VARIABLE Control**

Varies equivalent-time sweep rate continuously between steps of TIME/CM switch. Sweep speed is increased from rate indicated by TIME/CM switch as VARIABLE control is turned clockwise. Can extend fastest sweep rate (.1 nSEC/CM) to about 33 psec/cm. When making time measurements from display, be sure VARIABLE control is set to CAL position (counterclockwise detent).

**TIME POSITION RANGE Indicator**

Indicates time range through which TIME POSITION and FINE controls can move start of crt display "time-window." Range is read on blue TIME POSITION RANGE scale, as indicated by blue tab on clear skirt of knob.

**TIME POSITION and FINE Controls**

Position start of sweep through time range indicated by TIME POSITION RANGE indicator to move display time window and to position time-reference point for magnification. Fully clockwise position of each control provides minimum sampling delay (maximum lead time).



## Operating Instructions—Type 1S1

SAMPLES/CM Control	Adjust number of samples (dots) displayed per cm of horizontal displacement, and thus adjusts display repetition rate, when DISPLAY MODE switch is set to NORMAL or SINGLE SWEEP. Normally is adjusted for maximum resolution with minimum display flicker. Dot density is continuously variable from approximately 5 samples/cm in counterclockwise detent position (SWEEP OFF), dot is displayed on crt screen and may move extremely slowly across screen. SAMPLES/CM control does not function when DISPLAY MODE switch is at EXT HORIZ or MAN positions.
DISPLAY MODE Switch	Selects one of 4 modes of display presentation: NORMAL—Presents normal repetitive-sweep display; SINGLE SWEEP—Presents single sweep of display each time START button is pressed; EXT HORIZ—Permits application of external sweep signal through EXT HORIZ INPUT jack; MAN—Permits manual scan of equivalent-time display with MANUAL SCAN control.
START (Pushbutton) Switch	Starts single sweep of display when button is pressed if DISPLAY MODE switch is set to SINGLE SWEEP position. Sweep is then held off until START button is pressed again or until DISPLAY MODE switch is set to another position.
MANUAL SCAN or EXT HORIZ ATTEN Control	Manually moves crt spot horizontally to trace out equivalent-time display when DISPLAY MODE switch is set to MAN. Also serves as input attenuator for external scan voltage applied to EXT HORIZ INPUT jack when DISPLAY MODE switch is set to EXT HORIZ position. In either case, equivalent-time sweep rate of display is same as when DISPLAY MODE switch is set to NORMAL, and depends on setting of TIME/CM switch.
EXT HORIZ INPUT Jack	Permits application of external signal for scanning equivalent-time display when DISPLAY MODE switch is set to EXT HORIZ position. Attenuation of input signal is adjusted by EXT HORIZ ATTEN control, and equivalent-time sweep rate of display is set by TIME/CM control. Deflection factor is adjustable from 1 volt/cm to more than 16 volts/cm.
HORIZ OUTPUT Jack	Provides output waveform for driving horizontal deflection of display oscilloscope. Connection is made through oscilloscope External Horizontal Input jack. Output amplitude (through 10 k ohms) is 1 volt/cm, therefore oscilloscope horizontal deflection factor must be set to 1 volt/cm for correct equivalent-time sweep rates. Output signal may be used for driving pen recorder, since signal corresponds to real-time vertical signal available through VERT OUTPUT jack. When using normal stair-

case sweep, duration of output staircase steps depends on setting of SAMPLES/CM control, repetition rate of trigger circuit, and time position range used.

### FIRST-TIME OPERATION

The first 18 steps of the following procedure describe setting up the crt display when using a Type 1S1 and a display oscilloscope. These steps may be used in installing a Type 1S1.

The remaining steps of the procedure demonstrate the basic operation of the Type 1S1 front-panel controls. These demonstration steps are not required for setting up the sampling system.

1. With the display oscilloscope power turned off, insert the Type 1S1 in the plug-in compartment.
2. Set the oscilloscope Intensity control counterclockwise.
3. Turn on the oscilloscope power switch.
4. Connect a banana/banana patch cord from the Type 1S1 HORIZ OUTPUT jack to the oscilloscope External Horizontal Input jack.
5. Set the controls as follows:

#### Type 1S1

mVOLTS/CM	200
mVolts/Cm VARIABLE	CAL
VERT POSITION	Centered
DC OFFSET	At center of 10-turn range
TIME POSITION	Clockwise
FINE	Centered
SMOOTHING	NORM (Clockwise)
SAMPLES/CM	Centered
DISPLAY MODE	NORMAL
MANUAL SCAN EXT HORIZ ATTEN	Clockwise
TIME/CM	2 nSEC
Time/Cm VARIABLE	CAL
TRIGGER SOURCE	INT +
TRIGGER SENSITIVITY	Clockwise
RECOVERY TIME	Centered

#### Oscilloscope

Triggering controls	Set to hold off sweep
Horizontal Display	Ext $\times 1$
Amplitude Calibrator	5 v
Crt Cathode Selector	Chopped Blanking

6. Adjust the oscilloscope Intensity control to display a free-running trace of moderate brightness.
7. Adjust the DC OFFSET control to position the trace near the horizontal centerline.
8. Adjust the oscilloscope External Horizontal Input Variable control and Horizontal Position control to obtain approximately 10.2 cm of horizontal deflection.
9. Adjust the oscilloscope Focus and Astigmatism controls for the best presentation. The dots should be small, with equal vertical and horizontal dimensions.
10. Adjust the oscilloscope Trace Alignment control or crt adjustment to align the trace with the horizontal centerline.
11. Reset the Intensity control for a dim trace.
12. Remove the patch cord from the Type 1S1 HORIZ OUTPUT jack and connect it between the oscilloscope Calibrator Output connector and the oscilloscope External Horizontal Input jack. An adapter or a BNC/ banana patch cord may be required for the connection.
13. With the oscilloscope Horizontal Position control, position the left dot to the 1-cm graticule line (see Fig. 2-2).

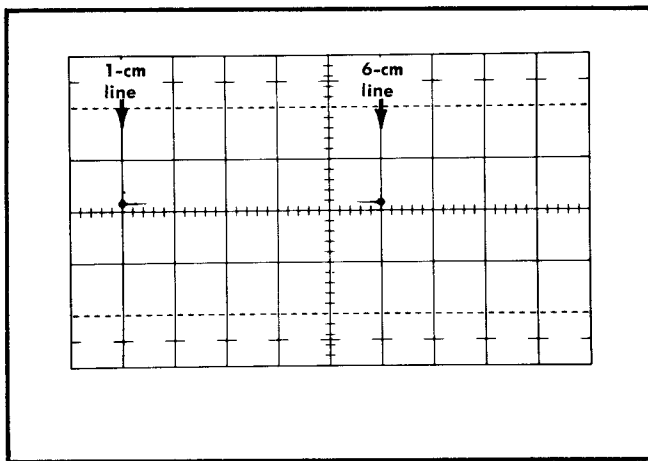

Fig. 2-2. Oscilloscope display for adjusting external horizontal deflection factor ( $\pm 4\%$ ).

14. Adjust the oscilloscope External Horizontal Input Variable control and Horizontal Position control to position the right-hand dot to the 6-cm graticule line while the left dot is at the 1-cm line.
15. Check that this adjustment is correct by positioning the pair of dots to the 4-cm and 9-cm graticule lines. If there is a difference in deflection, adjust the External Horizontal Input Variable control for a compromise setting.
16. Remove the patch cord from the Calibrator Output connector and reconnect it between the Type 1S1 HORIZ OUTPUT jack and the oscilloscope External Horizontal Input jack.
17. With the oscilloscope Horizontal Position control, position the start of the trace at the left edge of the graticule.
18. Before making any accurate voltage measurements from the display, check the vertical gain adjustment by ap-

plying a signal from an accurate 50-ohm source. The oscilloscope calibrator cannot be used for this adjustment unless it has an amplitude that is specified to be correct into 50 ohms.

19. Connect a positive-going pulse signal to the SIGNAL IN connector through a 50-ohm coax cable and attenuators as required. (A good signal for this purpose is a 600-mv 2-nsec pulse with a repetition rate of about 70 kc, such as the output pulse from a Tektronix Type 111 Pretrigger Pulse Generator applied through  $20\times$  attenuation). If the signal amplitude is greater than 1 volt, peak to peak, attenuate it with external attenuators. If the combined dc and peak ac voltage is over 1 volt, ac-couple the signal with a coupling capacitor at the SIGNAL IN connector.

20. Turn the TRIGGER SENSITIVITY control through its range of rotation. Note that the display is free running when the control is fully clockwise, that it is triggered when the control is approximately midrange, and that the display is held off when the control is turned fully counterclockwise. (It may be necessary to increase the intensity to view the triggered display.)

21. Set the TRIGGER SENSITIVITY control for a stable triggered display.

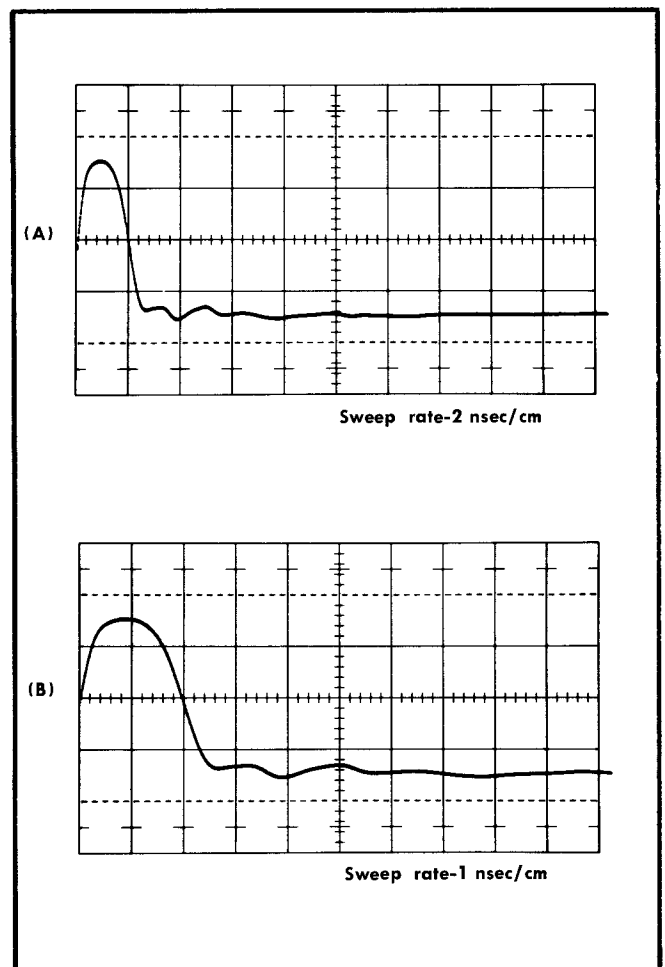

Fig. 2-3. Typical oscilloscope display illustrating time magnification of the display. Expansion takes place about the left edge of the screen.

## Operating Instructions—Type 1S1

22. With the DC OFFSET control, position the display to the center of the crt screen.

23. Turn the SAMPLES/CM control through its range of rotation and note the change in dot density from about 5 samples/cm at the MIN (clockwise) position to many thousands of samples/cm at the counterclockwise end of rotation.

### CAUTION

Always decrease the crt beam intensity whenever a stationary spot or slow-moving display is on the screen. Excessively high intensity can damage the crt screen.

24. Switch the SAMPLES/CM control to the SWEEP OFF position. The displayed dot remains on the crt screen at the position of the trace at the time the control was switched. (The dot may move slowly across the screen.)

25. Switch the SAMPLES/CM switch out of SWEEP OFF position and adjust it for as dense a trace as possible with minimum display flicker.

26. With the TIME POSITION control, move the displayed pulse to the left edge of the screen so that the trace starts on the pulse rise (see Fig. 2-3).

27. Pull out on the MAGNIFIER knob and turn the TIME/CM switch clockwise one position. Note that the display time-magnification takes place at the left edge of the screen. Also notice that there is no change in horizontal dot density. Since the equivalent time per cm is decreased, however, the dot density is **increased** in equivalent time, producing a more continuous trace on the pulse rise.

28. Turn the TIME/CM switch to the .5 nSEC, .2 nSEC and .1 nSEC positions. (It is not necessary to pull on the MAGNIFIER knob except when initially disengaging it from the TIME POSITION RANGE switch.) Observe the display expansion.

29. Return the TIME/CM switch to 2 nSEC. The MAGNIFIER knob will automatically engage with the TIME POSITION RANGE switch.

30. Set the DISPLAY MODE switch to SINGLE SWEEP.

31. Press the START button. A single triggered sweep of the display is presented each time the START button is pressed.

32. Set the DISPLAY MODE switch to MAN position.

33. Turn the red MANUAL SCAN (EXT HORIZ ATTEN) knob slowly counterclockwise and note that the same pulse display is traced out on the crt. The TIME/CM switch still determines the equivalent-time sweep rate of the display and the TIME POSITION control still determines the display position.

34. Connect a patch cord from the oscilloscope Sawtooth Output jack to the Type 1S1 EXT HORIZ INPUT jack.

35. Set the oscilloscope triggering controls for a free-running sweep to generate a sawtooth output.

36. Set the oscilloscope Time/Cm switch to 10 mSec.

37. Set the Type 1S1 DISPLAY MODE switch to the EXT HORIZ position.

38. Adjust the Type 1S1 EXT HORIZ ATTEN control for a horizontal deflection of about 10 cm. Notice that in this

mode, similar to manual scan, the external horizontal input voltage determines the crt spot position, but the Type 1S1 TIME/CM switch still determines the equivalent-time sweep rate of the display. Since the external voltage merely scans the display, the sawtooth voltage scans on both the ramp and retrace portions of the sawtooth waveform.

39. Turn the SAMPLES/CM control. Notice that the dot density of the display is not controlled by the SAMPLES/CM control when the display is externally scanned, but is instead controlled by the rate of scanning and by the trigger repetition rate. (The same is true when the display is manually scanned.)

40. Return the DISPLAY MODE switch to NORMAL.

41. Adjust the SAMPLES/CM control for a dense display with minimum flicker.

42. Set the TIME POSITION control to position the pulse display to the right of the vertical centerline.

43. Set the TRIGGER SOURCE switch to INT —.

44. Readjust the TRIGGER SENSITIVITY control if necessary for a triggered display. Notice that the displayed pulse has shifted to the left due to the fact that the triggering occurs at essentially the same time, but now is on the negative-going slope. (There is also a slight additional shift of 1 or 2 nsec due to the inverting transformer.)

45. Return the TRIGGER SOURCE switch to INT +.

46. Disconnect the pulse input signal.

47. Connect a 10-Mc sine wave of about 1 volt amplitude (e.g. from a Tektronix Type 180A through 5× attenuation) to the SIGNAL IN connector.

48. Set the TIME/CM switch to 50 nSEC.

49. Trigger the display with the TRIGGER SENSITIVITY control. The control should be set to the most stable triggering point.

50. Slowly turn the RECOVERY TIME control through its range of rotation. Note that several positions of the control provide stable triggering of the display.

51. Switch the RECOVERY TIME control to SYNC position.

52. Adjust the TRIGGER SENSITIVITY control for a stable display. This synchronized mode of operation is normally used for input signals from 20 Mc to 1 Gc.

53. Switch the RECOVERY TIME control out of SYNC position and set it to midrange. Readjust the TRIGGER SENSITIVITY control if necessary.

54. Turn the TIME POSITION and FINE controls fully clockwise.

55. With the TIME/CM MAGNIFIER knob locked to the TIME POSITION RANGE switch, set the TIME/CM switch to 20 nSEC. This sets the TIME POSITION RANGE switch to 500 nS. Each cycle of the 10-Mc waveform represents 100 nsec of time.

56. Observe the display while turning the TIME POSITION control fully counterclockwise. Notice that approximately  $4\frac{1}{2}$  cycles of the waveform, representing approximately 450 nsec, pass the left edge of the crt screen.

57. Turn the FINE control fully counterclockwise. Notice that approximately  $\frac{1}{2}$  cycle of the waveform, representing 50 nsec, passes the left edge of the screen. Thus the total positioning capability is 500 nsec, as indicated by the TIME POSITION RANGE switch. The FINE control has about  $\frac{1}{10}$ th of the time positioning range of the TIME POSITION control.

58. Turn the TIME/CM switch to  $.2 \mu\text{SEC}$ , setting the TIME POSITION RANGE switch to  $5 \mu\text{S}$ .

59. Pull out on the MAGNIFIER knob and turn the TIME/CM switch back to 20 nSEC. The sweep rate and display are now the same as before, except that now the time positioning controls have a range of  $5 \mu\text{sec}$ , and the display repetition rate is reduced.

60. Turn the FINE control through its range of rotation. Notice that now the control moves approximately  $4\frac{1}{2}$  cycles of the waveform past the left edge of the crt screen. (At this time position range, the TIME POSITION control would move approximately 45 cycles of the waveform through the edge of the "time window". Thus the total time positioning capability is approximately  $5 \mu\text{sec}$ , as indicated by the TIME POSITION RANGE switch.)

61. Set the TIME/CM switch to  $.2 \mu\text{SEC}$  to engage the MAGNIFIER knob with the TIME POSITION RANGE switch, then turn the TIME/CM switch to 1 nSEC. There is now approximately  $\frac{1}{10}$ th of a cycle displayed.

62. Position the top or bottom of the waveform to the center of the screen with the TIME POSITION control.

63. Set the mVOLTS/CM switch to 2.

64. With the DC OFFSET control, position the tip of the waveform on the screen.

65. Turn the SMOOTHING control fully counterclockwise. Notice the decrease in display noise with smoothing.

66. Return the mVOLTS/CM switch to 200.

67. Set the TIME/CM switch to 5 nSEC.

68. With the SMOOTHING control set fully counterclockwise, turn the SAMPLES/CM control to MIN position (fully clockwise). Notice the decrease in display amplitude, due to the combination of full smoothing and minimum dot density. This illustrates the need for a relatively high dot density when smoothing is used.

69. Turn the SMOOTHING control to NORM (fully clockwise). The display amplitude is returned to normal, even with minimum dot density.

70. Readjust the SAMPLES/CM control for a normal trace with maximum dot density and minimum flicker.

71. Insert a  $10\times$  attenuator in the signal path.

72. Retrig the display with the TRIGGER SENSITIVITY control.

73. Set the VERT POSITION control to midrange.

74. Center the trace with the DC OFFSET control.

75. Turn the VERT POSITION control through its range of rotation. The overall range of the control is more than 10 cm, thus positioning the display off screen both upward and downward. Leave the VERT POSITION control at midrange.

76. Turn the DC OFFSET control fully counterclockwise, then fully clockwise. Notice that the positioning capability of the control is more than  $\pm 5$  cm, representing  $\pm 1$  volt at this 200 mv/cm deflection factor.

77. Set the mVOLTS/CM switch to 20.

78. Turn the DC OFFSET control and notice that the display positioning capability has increased, since at this deflection factor the  $\pm 1$  volt offset provides  $\pm 50$  cm of positioning. (At 2 mv/cm the positioning range is  $\pm 500$  cm.)

79. Center the trace with the DC OFFSET control.

80. Turn the VERT POSITION control through its range of rotation. Notice that this control still has approximately 10 cm of positioning capability. This is true regardless of the input deflection factor.

81. Disconnect the input signal. This concludes the demonstration of front-panel control functions.

## OPERATIONAL ADJUSTMENTS

Whenever the Type 1S1 is transferred from one oscilloscope to another, the external horizontal deflection factor of the oscilloscope must be adjusted to 1 volt/cm and the vertical gain of the system should be checked.

Occasional checks should also be made of the smoothing balance, the vertical attenuator balance, the attenuator variable balance and the vertical position range. In general, the need for the balance and position adjustments will be obvious from the display, as described below. Allow at least 20 minutes warm up of the Type 1S1 before making any of these adjustments.

In addition to these normal operational checks, it may sometimes be necessary to check the sampling loop gain if the display seems to have an incorrect amount of overshoot or rolloff.

### Horizontal Deflection Adjustment

To provide correct equivalent-time sweep rates, the horizontal deflection factor of the oscilloscope must be adjusted to 1 volt/cm to match the calibrated 1 volt/cm horizontal output of the Type 1S1. Any accurate low-impedance voltage signal or dc voltage source from about 4 volts to 8 volts in amplitude can be used for making this adjustment.

One method, using the oscilloscope calibrator 5-volt square-wave signal, has been described under "First-Time Operation". This method is easy and fast but provides an accuracy within only about 4%, including about 1% possible error in reading the display. If the oscilloscope 5-volt calibrator signal amplitude is more accurate than the 3% tolerance, the timing error may be much less than 4%. On the other hand, if the calibrator signal is not exactly 5 volts, but its amplitude is accurately known, the deflection factor can also be adjusted accurately by setting the centimeters of deflection to equal the known amplitude in volts.

Another method of adjusting the horizontal deflection factor is given in the timing calibration adjustment in Section 5. This method, which provides an accuracy within about 1%, uses a differential comparator oscilloscope for adjusting the square-wave amplitude to within 0.5% of 8 volts.

## Operating Instructions—Type 151

Use either of these methods, as described in the procedures, or make use of some other accurate voltage source. The differential comparator can be used to check the 5-volt calibrator amplitude, after which the horizontal deflection adjustment can be made to within about 2% accuracy with only the calibrator signal.

### Smoothing Balance Adjustment

If the trace (with no signal applied) moves vertically as the SMOOTHING control is turned, adjust the smoothing (memory) balance adjustment as follows:

1. Remove the left side panel of the oscilloscope (or extend a rack-mounted oscilloscope).
2. Locate the MEMORY BAL adjustment control (R110) shown in Fig. 2-4.
3. Alternately adjust the control, then turn the SMOOTHING control, until there is no vertical trace movement as the SMOOTHING control is turned.

While the oscilloscope side panel is off, also check the attenuator and variable balance adjustments and the vertical position range adjustment as given in the following procedures.

### Attenuator Balance Adjustment

With the dc offset at zero volts and with no signal applied, if the trace moves vertically on the crt screen as the mVOLTS/CM switch is turned from one position to another, adjust the attenuator balance as follows:

1. First check and adjust the smoothing balance as described above.

2. Set the DC OFFSET control to zero volts by monitoring the OFFSET OUTPUT jack with a high-impedance voltmeter or a dc-coupled test oscilloscope. Another method of setting the dc offset to zero volts is by moving the patch cord connector from the HORIZ OUTPUT jack to the OFFSET OUTPUT jack to monitor the offset voltage. When the output voltage is zero, the crt spot will not move horizontally as the patch cord connector is touched to or removed from the OFFSET OUTPUT jack.

3. With the mVOLTS/CM switch at 200, position the free-running trace on the horizontal centerline with the VERT POSITION control.

4. Set the mVOLTS/CM switch to 2.

5. Locate the BRIDGE BAL adjustment control (R30) shown in Fig. 2-4.

6. Adjust R30 to reposition the trace to the center of the crt screen.

7. Repeat steps 3 and 4 to check the adjustment.

### Variable Balance Adjustment

With the dc offset at zero volts and with no signal applied, if the trace moves vertically on the crt screen as the mVolts/Cm VARIABLE control is rotated, adjust the variable balance as follows:

1. First check and adjust the smoothing balance and attenuator balance as described above.

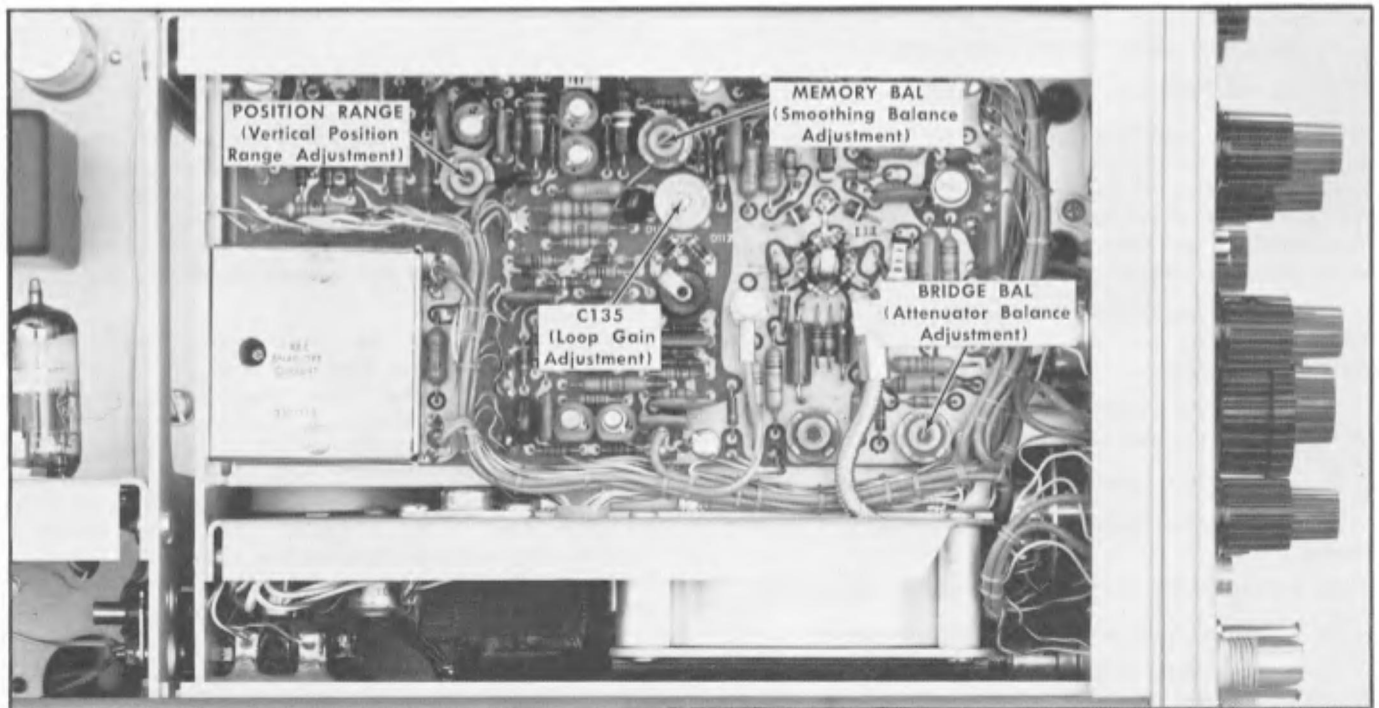

Fig. 2-4. Operational adjustment controls on the left side of the Type 151.

2. Set the DC OFFSET control for zero volts at the OFF-SET OUTPUT jack.
3. Set the mVOLTS/CM switch to 200.
4. Turn the mVolts/Cm VARIABLE control clockwise to the point of maximum sensitivity.
5. With the VERT POSITION control, position the free-running trace to the horizontal centerline.
6. Return the mVolts/Cm VARIABLE control to the CAL detent position.
7. With a small screwdriver, adjust the front-panel VAR BAL control to return the trace to the horizontal centerline.
8. Repeat steps 4, 5 and 6 to check the adjustment.
9. Leave the mVolts/Cm VARIABLE control set to the CAL position.

### Vertical Position Range Adjustment

With the dc offset at zero volts and with no signal applied, if the VERT POSITION control does not have enough range to move the trace off the screen in one direction or the other, the position range control may need to be adjusted. First, however, check the 3 balance adjustments given above. If the balance adjustments are correct but the range of the VERT POSITION control is not correct, make the adjustment as follows:

1. Set the DC OFFSET control for zero volts at the OFF-SET OUTPUT jack.
2. Center the VERT POSITION control so that the white dot points straight up.
3. Locate the POSITION RANGE adjustment control (R194) shown in Fig. 2-4.
4. Adjust R194 to position the free-running trace to the horizontal centerline.

### Vertical Gain Adjustment

The vertical gain of the Type 1S1 should be adjusted when the unit is first installed in an oscilloscope and should be checked occasionally thereafter.

The use of a 50-ohm amplitude calibrator, as described in the calibration procedure in Section 5, is recommended for this adjustment. The procedure given there provides an accuracy within about 1%.

Another method of checking the vertical gain can be used if the oscilloscope 1-kc calibrator has a position that is calibrated into 50 ohms (e.g. 0.1 V Into 50  $\Omega$  at the .5 Volts position). However, since the calibrator tolerance is  $\pm 3\%$ , accuracy of the check with the oscilloscope calibrator will be only within about 4%, unless the amplitude error is known.

The following procedure is suggested for use of the 0.1 V Into 50  $\Omega$  calibrator signal:

1. Set the TIME/CM switch to 50  $\mu$ sec.
2. Connect the oscilloscope calibrator directly to the Type 1S1 SIGNAL IN connector through an adapter and a coax cable.

3. Set the calibrator to the 0.1 V Into 50  $\Omega$  position.
4. Set the Type 1S1 mVOLTS/CM switch to 20.
5. Trigger the crt display with the TRIGGER SENSITIVITY control.
6. Check for 5 cm of vertical deflection (see Fig. 2-5). If the amount of error in the calibrator signal is known, check the display for a vertical deflection of 200 mv/cm.

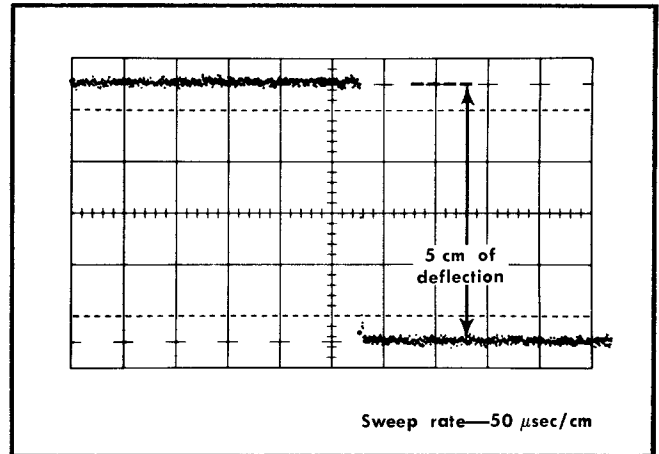

Fig. 2-5. Typical oscilloscope display for checking vertical deflection factor ( $\pm 4\%$ ) with oscilloscope calibrator.

7. If the vertical gain is not correct, use a small screwdriver to adjust the front-panel VERT GAIN control.

### Loop Gain Adjustment

To present a correct display on the crt screen when using a low dot density, the dot transient response of the sampling channel must be correct. That is, the gain of the sampling feedback loop must be set so that each display dot accurately represents the signal level at the time the sample was taken. If loop gain is greater than unity (gain of 1), the display will be excessively noisy and have overshoot. If loop gain is less than unity, the rising portions of fast pulses will be rolled off when using a low dot density, and the display amplitude will be decreased for sine waves.

In the Type 1S1, loop gain is adjusted to unity with the SMOOTHING control set to the fully clockwise NORM position. The SMOOTHING control can then be used to decrease loop gain when necessary to reduce display noise.

Use a 1-volt 40-kc fast-rise pulse approximately 20 nsec in duration, as described in the calibration procedure, for checking loop gain. This check causes the loop to process a 1-volt change between each two samples, thus detecting any variation from unity gain.

## INPUT SIGNAL CONNECTIONS

### General Information

The input circuits for both the vertical signal and the external triggering signal are designed to have the character-

## Operating Instructions—Type 1S1

istics of a 50-ohm transmission line. This permits the use of 50-ohm coax cables for applying the input signals with minimum signal loss or distortion.

When connecting the signal from the source to the Type 1S1, many factors must be taken into consideration including loading of the source, signal losses in the cables, time delay, coupling and attenuating the signal, and matching impedances. This portion of the manual discusses these factor with respect to the vertical input signal. Connections for applying an external triggering signal are discussed later under "Triggering the Display".

### Coax Cables

Signal cables that connect the vertical signal from the source to the Type 1S1 SIGNAL IN connector should have a characteristic impedance of 50 ohms. Impedances other than 50 ohms will cause reflections that will make it difficult to interpret the display. High-quality low-loss coaxial cables should be used to insure that all the information obtained at the source will be delivered to the Type 1S1 vertical input. If it is necessary to use cables with characteristic impedances other than 50 ohms, suitable impedance-matching devices will aid in the transition.

The characteristic impedance, velocity of propagation and nature of signal losses in a coaxial cable are determined by the physical and electrical characteristics of the cable. Losses caused by energy dissipation in the dielectric are proportional to the signal frequency. Therefore much of the high-frequency information in a fast-rise pulse can be lost in a very few feet of interconnecting cable.

Fig. 2-6. shows the relative increase in output signal risetime when a step input signal is passed through several types of commonly used 50-ohm coax cables. This increase in output risetime must be taken into consideration when making risetime determinations. For example, a length of cable with a 225-psec output risetime will degrade a 500-psec input risetime by about 10%. (This may be determined by the "root of the sum of the squares" formula.) As can be seen from

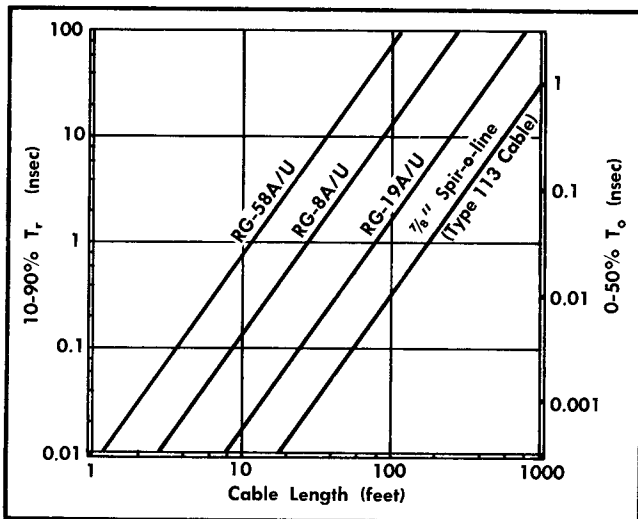

Fig. 2-6. Output signal risetime in response to a step input, given as a function of cable length for some common coaxial cables.

the graph, it takes only 6 feet (9 nsec) of RG-58A/U cable to cause this 10% change. However, it will take about 15 feet (22.5 nsec) of RG-8A/U or 80 feet (95 nsec) of Spir-o-line to cause the same amount of change. If signal delay greater than 60 nsec is required, the use of a Tektronix Type 113 Delay Cable is recommended.

It is important to note that the risetime of the transmitted signal deteriorates approximately in proportion to the square of the length of the cable. As an illustration, a 500-psec risetime would be increased to 1000 psec (100% increases) by a length of cable with a risetime of about 867 psec. From Fig. 2-6 it is seen that approximately 10 feet (15 nsec) of RG-58A/U, 25 feet (37.5 nsec) of RG-8A/U or 115 feet (137 nsec) of Spir-o-line would cause this amount of risetime change. Comparing this result with the previous determination, it is seen that a 67% increase in cable length would produce a 900% increase in risetime deterioration for the 500-psec pulse risetime.

Due to the high-frequency losses in coax cables, the 0-50% half-amplitude risetime ("T nought",  $T_0$ ) is often used instead of the 10-90% measurement that is used with amplifiers.  $T_0$  is approximately equal to 1/30th the 10-90% risetime of the coax cable output.

Occasionally, it may be desirable to use long 50-ohm cables to move reflections out of the "time window" of interest (delayed by double the transit time of the cable). Keep in mind, however, the degrading effect that long lengths of delay cable have on the pulse risetime.

### Coupling

If there is a dc voltage greater than  $\pm 2$  volts associated with the signal source, a coupling capacitor must be used to block the dc voltage. If a capacitor is not used, the signal will be offset and will not be positionable on the screen. In addition, voltage in excess of  $\pm 5$  volts may damage the input circuitry.

### Attenuation

Maximum signal amplitude that should be applied to the Type 1S1 SIGNAL IN connector is  $\pm 2$  volts, combined dc and peak ac. If the signal amplitude at the source is too great, use an attenuator probe and/or externally-connected T-attenuators. The attenuators that are used must have a bandpass to about 2 Gc to avoid reducing the performance of the system. High-quality 50-ohm attenuators are available with attenuation factors of 10 $\times$ , 5 $\times$  and 2 $\times$ . When the attenuators are stacked, their attenuation factors multiply. Thus, two 10 $\times$  attenuators produce a 100 $\times$  attenuation factor.

### Impedance Matching

To provide a smooth transition between devices of different characteristic impedance, each device must encounter a total impedance equal to its own characteristic impedance. Thus, when a signal is applied to the Type 1S1 SIGNAL IN connector, if the source impedance of the signal is not 50 ohms, a suitable impedance-matching device must be provided. If the impedances are not matched, reflections and standing waves in the cables will result in distortion of the displayed waveform.



In many cases, insertion of a 50-ohm attenuator in the signal path will provide an approximate impedance match and will absorb most reflections. It should be noted, however, that the attenuation factor will not be the same as it would be if the impedances were the same on both sides.

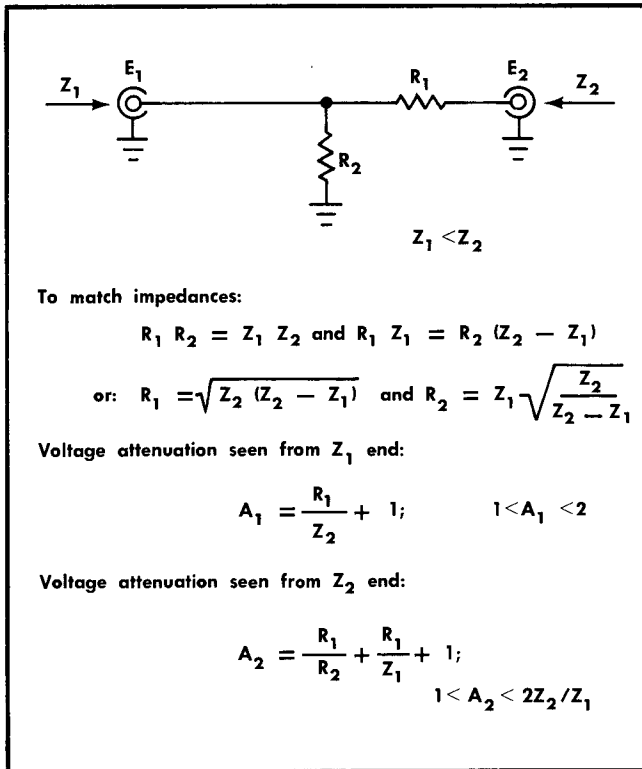

Fig. 2-7. Simple resistive impedance-matching network providing minimum attenuation.

Fig. 2-7 illustrates a simple resistive impedance-matching network that provides minimum attenuation. To match impedances with the network, the following conditions must exist:

$$\frac{(R_1 + Z_2) R_2}{(R_1 + Z_2) + R_2} \text{ must equal } Z_1; \text{ and } R_1 + \frac{Z_1 R_2}{Z_1 + R_2} \text{ must equal } Z_2.$$

Therefore:

$$R_1 R_2 = Z_1 Z_2; \text{ and } R_1 Z_1 = R_2 (Z_2 - Z_1)$$

or  $R_1 = \sqrt{Z_2 (Z_2 - Z_1)}$ ;  
 and  $R_2 = Z_1 \sqrt{\frac{Z_2}{Z_2 - Z_1}}$

As an example, to match a 50-ohm system to a 125-ohm system:

$$Z_1 = 50 \text{ ohms; and } Z_2 = 125 \text{ ohms.}$$

Therefore:

$$R_1 = \sqrt{125 (125 - 50)} = 96.8 \text{ ohms}$$

and  $R_2 = 50 \sqrt{\frac{125}{125 - 50}} = 64.6 \text{ ohms}$

When constructing such a device, the environment surrounding the components should also be designed to provide a transition between the impedances. Keep in mind that the characteristic impedance in a coaxial system is determined by the ratio between the outside diameter of the inner conductor and the inside diameter of the outer conductor ( $Z_0 = 138 \log_{10} D_1/D_2$ ).

Though the network in Fig. 2-7 provides minimum attenuation for a purely resistive impedance-matching device, the attenuation as seen from one end does not equal that seen from the other end. A signal applied from the lower impedance source ( $Z_1$ ) encounters a voltage attenuation ( $A_1$ ) that may be determined as follows:

Since:  $i_{R1} = i_{Z2}; \frac{E_1 - E_2}{R_1} = \frac{E_2}{Z_2}$

Therefore:  $A_1 = \frac{E_1}{E_2} = \frac{R_1}{Z_2} + 1; (1 < A_1 < 2)$

A signal applied from the higher impedance source ( $Z_2$ ) will encounter a greater voltage attenuation ( $A_2$ ) that may be determined similarly:

Since:  $i_{R1} = i_{R2} + i_{Z1}; \frac{E_2 - E_1}{R_1} = \frac{E_1}{R_2} + \frac{E_1}{Z_1}$

Therefore:  $A_2 = \frac{E_2}{E_1} = \frac{R_1}{R_2} + \frac{R_1}{Z_1} + 1;$

$$(1 < A_2 < \frac{2Z_2}{Z_1})$$

In the example of matching 50 ohms to 125 ohms,

$$A_1 = \frac{96.8}{125} + 1 = 1.77;$$

$$\text{and } A_2 = \frac{96.8}{64.6} + \frac{96.8}{50} + 1 = 4.44$$

Note that if the 50-ohm source were used for pulsing a high-impedance load,  $R_1$  would approximately equal the impedance of the load (high R) and  $R_2$  would approximately equal the 50 ohms of the pulse source. In this situation, voltage attenuation would be about 2.

If a low-impedance load (<50 ohms) were to be encountered, the 50-ohm pulse source would be the  $Z_2$  source. If the load impedance were to approach 0 ohms, the value of  $R_1$  would then approach the load impedance (low R). Voltage attenuation in this case would become quite significant:

$$\text{Attenuation} = \frac{2Z_2}{Z_L} = \frac{100}{Z_L} \text{ (very high)}$$

The illustrated network can be modified to provide different attenuation ratios by adding another resistor (< $R_1$ ) in series between  $Z_1$  and the junction of  $R_1$  and  $R_2$ .

### Probes

For relatively high-impedance measurements of nanosecond signals, special passive or cathode-follower signal probes are available for use with the Type 1S1 Sampling Unit. Passive probes may also be built into or onto the circuits to be monitored, to minimize changes in loading.

## Operating Instructions—Type 151

**Passive Probes.** The Tektronix P6034 10× Probe and the P6035 100× Probe are moderate-resistance passive probes designed for use with 50-ohm systems. They are small in size, permitting measurements to be made in miniaturized circuitry. Power rating is 0.5 watt up to a frequency of 500 Mc. Momentary voltage peaks up to 500 volts can be permitted at low frequencies, but voltage derating is required at higher frequencies. Characteristic data is given in the probe instruction manuals.

The P6034 10× Probe places 500 ohms resistance and less than 0.8 pf capacitance in parallel with the signal source at low frequencies. The probe bandpass is dc to approximately 3.5 Gc, and risetime is 100 psec or less (10%-90%). At 1 Gc, the input resistance is about 300 ohms and the capacitive reactance is about 450 ohms.

The P6035 100× Probes places 5 k ohms resistance and less than 0.7 pf capacitance in parallel with the signal source at low frequencies. Bandpass of the probe is dc to approximately 1.5 Gc, and risetime is 200 psec or less (10%-90%). At 1 Gc the input resistance is about 2 k ohms and the capacitive reactance is about 450 ohms.

The P6026 Passive Probe, also designed for use with 50-ohm systems, has a bandpass of dc to approximately 600 Mc when dc-coupled, and a risetime of 600 psec or less. The probe consists of a coax cable, connectors, ac-coupled and dc-coupled 50-ohm terminations, and seven attenuator heads with attenuation factors from 5 to 5000.

**Cathode-Follower Probes.** The Tektronix P6032 Cathode-Follower Probe is a high-impedance high-frequency probe for Tektronix sampling systems. Bandpass is dc to approximately 850 Mc and risetime is 400 psec or less. Seven attenuator heads are provided, with attenuation factors from 10× to 1000× for the combination of probe and attenuator. Input resistance is 10 megohms at dc, and the parallel capacitance ranges from 1.3 pf to 3.6 pf, depending on the attenuator head used. At 1 Gc, the capacitive reactance is about 100 ohms and the input resistance is about 100 ohms for the 10× attenuator and 2 k ohms for the 1000× attenuator.

The advantage of the cathode-follower probe is the high input resistance and low capacitive loading at moderately high frequencies. Dynamic characteristic data is given in the probe instruction manual.

**Built-In Probes.** Another satisfactory method of coupling fractional nanosecond signals from within a circuit is to design the circuit with a built-in 50-ohm output terminal. With this method, the circuit can be monitored without being disturbed. When the circuit is not being tested, a 50-ohm terminating resistor can be substituted for the test cable. If it is not convenient to build in a permanent 50-ohm test point, an external coupling circuit, which may be considered a probe, can be attached to the circuit.

Several factors must be considered when constructing such a built-in signal probe. A probe is designed to transfer energy from a source to a load, with controlled fidelity and attenuation. Both internal and external characteristics affect its operation. It must be able to carry a given energy level, be mechanically adaptable to the measured circuit, and be equally responsive to all frequencies within the limits of the system. The probe must not load the circuit significantly or the display may not present a true representation of the circuit operation. Loading may even disrupt the opera-

tion of the circuit. When it is necessary to ac-couple the probe, the capacitor should be placed between the series resistance and the probe cable to minimize differences between the input characteristics with and without the capacitor. In this 50-ohm environment, stray capacitance to ground has a shorter and more uniform time constant than if the capacitor were placed at the signal source where the impedance is usually higher and of unknown value.

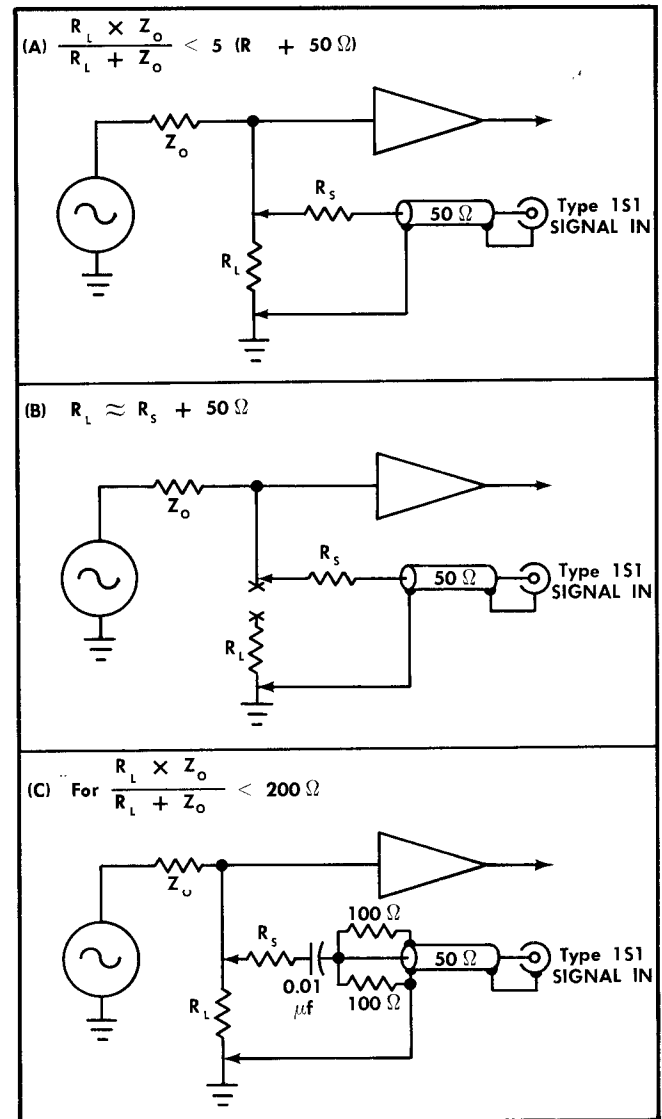

Fig. 2-8. Built-in probes for coupling to a test circuit. (A) Parallel method; (B) series method; (C) reverse-terminated parallel method.

Fig. 2-8A shows the parallel method of coupling to a circuit under test. Resistor  $R_s$  is connected in series with the 50-ohm input cable to the Type 151, placing  $R_s + 50$  ohms across the impedance in the circuit. This method usually requires the use of an amplitude correction factor. In order to avoid over-loading the circuit, the total resistance of  $R_s + 50$  ohms should not be less than 5 times the impedance of the device ( $R_L$  in parallel with  $Z_o$ ) requiring a 20% correction. The physical position of  $R_s$  will affect the fidelity of the coupling.

Fig. 2-8B shows the series method of coupling to a circuit. Resistor  $R_s$  plus the 50-ohm input of the Type 1S1 replaces the impedance of the circuit under test. If  $R_L$  is 50 ohms, simply substitute the 50-ohm test cable with no additional series resistance. It is best to locate  $R_s$  in the original position of  $R_L$  and to ground the coax where  $R_L$  was grounded.

A variation of the parallel method is the reverse-terminated network shown in Fig. 2-8C. This system may be used across any impedance up to about 200 ohms. At higher source impedances, circuit loading would require more than 20% correction. The two 100-ohm resistors across the cable input serve to reverse-terminate any small reflections due to connectors, attenuators, etc. The series capacitor, which is optional, blocks any dc component and protects the resistors.

## TRIGGERING THE DISPLAY

Selection of the triggering source and method of coupling will depend primarily on the amplitude of the applied signal, the frequency or repetition rate of the signal and the time relationship of the signal to the desired crt display.

Each sample to be displayed on the crt screen requires a separate trigger recognition by the trigger circuit. The sampling rate is determined by the frequency of the input signal, the settings of the triggering controls and the setting of the TIME POSITION RANGE switch. For triggered operation on signal frequencies below the maximum repetition rate of the trigger circuit (e.g. 80 kc on the 500  $\mu$ S and 50  $\mu$ S time position ranges), each cycle of the input triggering signal produces one trigger pulse and displays one sample. Above the repetition rate of the trigger circuit, one trigger pulse is produced and one sample is displayed for every two or more cycles of the input triggering signal, due to the count-down operation of the circuit.

### Triggering Sources

The triggering signal may be obtained either internally from the trigger takeoff in the vertical channel or externally from the front-panel EXT TRIG connector, as selected by the TRIGGER SOURCE switch. The methods of applying the external triggering signal are discussed below under "Triggering From an External Source".

**Internal Triggering.** When the TRIGGER SOURCE switch is set to either INT+ or INT—, the portion of the vertical signal taken off by the trigger takeoff transformer at the vertical input is applied to the trigger circuit. This allows the trigger to start the sampling operation while the input signal is traveling through the delay line to the sampling gate. Triggering internally from the vertical input signal is the most convenient method under most circumstances, since no external triggering connections are required. The time delay provided by the internal delay line, the time positioning capability of the TIME POSITION controls and the ability to trigger on either the positive-going or negative-going slope of the signal permit internal triggering on most common input signals. With minimum sampling delay (TIME POSITION controls clockwise), sampling of the input signal starts approximately 4 nsec (on the 500 nS ramp) before the triggering signal reaches the sampling gate. (Minimum delay is greater on the slower time position ranges.)

**External Triggering.** When the TRIGGER SOURCE switch is set to either EXT+ or EXT—, the signal applied to the front-panel EXT TRIG connector is applied to the trigger circuit. For the crt display to be meaningful, this triggering signal must be time-related to the vertical input signal applied to the SIGNAL IN connector. In addition to providing the advantage of triggering on smaller signals, external triggering also establishes a time relationship between different input signals, provides time positioning outside the time domain of the Type 1S1 TIME POSITION controls, and avoids the readjustment of triggering controls when a series of time-related input signals is to be observed.

**Free Run.** Both trigger sources (the trigger takeoff and the EXT TRIG input) are disconnected from the trigger circuit when the TRIG SOURCE switch is set to FREE RUN position. In addition, the circuit operation is changed so that it will free run regardless of the setting of the TRIGGER SENSITIVITY control.

Free run operation is provided primarily to present a trace on the crt for setting up the display. It is also used when displaying a spot on the crt screen with the DISPLAY MODE switch set to MAN or EXT HORIZ, and when using real-time sampling at very low frequencies (see "Real-Time Sampling Operation" later in this section).

Normally, the trace may also be free run by turning the TRIGGER SENSITIVITY control fully clockwise. If an input signal is connected, however, the trigger circuit may synchronize with the signal and it may not be possible to free run the trigger. In this case, if a free running display is desired, the TRIGGER SOURCE switch should be set to FREE RUN position.

### Triggering Signal Requirements

**Repetition Rate or Frequency.** The input to the trigger circuit is capacitively-coupled, with an RC time constant that limits sine-wave triggering to frequencies above approximately 100 kc. Pulse triggering, however, provides stable triggering down to single pulses. With either sine waves or pulses, high-frequency triggering is stable up to at least 1 Gc.

For triggering on low repetition-rate pulses, the rate of pulse rise must be 7 mv/ $\mu$ sec or faster for internal triggering, or 1 mv/ $\mu$ sec for external triggering. This means, for example, that for triggering internally on a 350-mv pulse, the risetime must be 40  $\mu$ sec or less. That is, the rate of rise between the 10% and 90% levels (280 mv) must be 7 mv/ $\mu$ sec or faster.

Pulse triggering below approximately 50 cps is not generally practical, since it takes at least 50 dots to make one sweep of the crt, and the display dots may drift slightly at these very low repetition rates.

**Amplitude.** The amplitude of the internally-derived triggering signal is only about 1/7th the amplitude of the vertical input signal. Therefore, a signal applied to the SIGNAL IN connector must be proportionately greater in amplitude than a triggering signal applied through the EXT TRIG connector to provide the same triggering capability.

Internal triggering on pulses and other fast-rise waveforms requires an amplitude of 40 mv or more. For internal

## Operating Instructions—Type 1S1

sine-wave triggering, an amplitude of 50 mv or more (peak to peak) is required. Since the maximum amplitude to be applied to the SIGNAL IN connector is  $\pm 2$  volts, combined dc and peak ac, this is also the upper limit obtainable for internal triggering. The TRIGGER SENSITIVITY control has adequate range for triggering on any signal between these amplitude limits.

External triggering on fast-rise waveforms requires an amplitude of 7 mv or more at the EXT TRIG connector. External sine-wave triggering requires an amplitude of 8 mv or more, peak to peak. Maximum amplitude of the input triggering signal applied to the EXT TRIG input connector should not be over  $\pm 200$  mv. The input circuitry will not be damaged by voltages up to  $\pm 2$  volts, but above 200 mv the TRIGGER SENSITIVITY control may not be able to control the triggering operation. External 50-ohm attenuators may be used to reduce the amplitude to the required level. (A convenient amplitude for the signal is about 150 mv.)

### Triggering From an External Source

To be able to view the signal that triggers the Type 1S1, triggering must take place approximately 40 nsec before the input signal reaches the sampling gate. For internal triggering, this time difference is provided by the internal delay line in the vertical signal path between the trigger takeoff and the sampling gate.

Since external triggering signals are applied to the trigger circuit in the same manner as internal triggering signals, the external triggering signal will have to reach the EXT TRIG connector at approximately the same time as the vertical signal reaches the SIGNAL IN connector. Otherwise, the desired signal may occur outside the "time window" of the crt screen. The time positioning controls of the Type 1S1 provide a relatively wide range of time positioning of the display that is adequate for most purposes. However, to view some portion of the signal that is not within the range of the time positioning controls, it is necessary to use external triggering to advance or delay the triggering signal with respect to the vertical input signal.

### Coupling

The EXT TRIG input is connected to the trigger circuit (ac-coupled) when the TRIGGER SOURCE switch is set to either EXT+ or EXT-. When the switch is set to either of the INT positions, the EXT TRIG input is terminated in 50 ohms. The impedance of the cable or other device used to apply the external triggering signal should be approximately 50 ohms. An impedance above 50 ohms will attenuate the signal and result in poor triggering.

Even though the input to the trigger circuit is capacitively coupled, the triggering signal should not have a large dc component. If the signal has a dc component greater than  $\pm 2$  volts at the signal source, connect it to the EXT TRIG connector through a coupling capacitor. Be sure to take this capacitance into consideration when determining the low-frequency cutoff of the input coupling.

### Sources

External triggering signals may be obtained from a test device, from a pulse generator that is pulsing a test device,

or from the same signal that is applied to the vertical input. Several types of connecting devices are available for connecting the triggering signal to the Type 1S1. These include attenuator probes, voltage or current pickoff devices, T-connectors and coaxial cables. Some of these are suggested in Table 2-2. Be sure the amplitude of the triggering signal does not exceed the limits given above under "Triggering Signal Requirements".

**Probes.** For many applications, a trigger probe can be used to trigger the Type 1S1 if a signal that is time-related to the input signal can be taken from the device under test. The probe is connected to the EXT TRIG connector through an adapter or through a coupling capacitor and an adapter. The Tektronix P6034 Probe provides  $10\times$  attenuation with an input resistance of 500 ohms and input capacitance of about 0.8 pf. The Tektronix P6035 Probe provides  $100\times$  attenuation with 5 k ohms input resistance and about 0.7 pf capacitance. For amplitudes above about 16 volts, use a coupling capacitor with the probe.

**Current Takeoff.** When a portion of the input signal must be taken off for triggering, some means of dividing the signal without introducing severe distortion must be found. One suitable takeoff device is the Tektronix CT-3 Current Takeoff. This is a feed-through device that is inserted into the 50-ohm signal path and takes off a small portion of the signal. The output voltage to the trigger circuit, through a BNC connector, is about 1/10th of the amplitude of the feed-through signal.

**Voltage Pickoff.** The Tektronix VP-1 Voltage Pickoff may be used in conjunction with a P6034 Probe or P6035 Probe to take a portion of the signal from the 50-ohm system. The VP-1 is inserted into the 50-ohm signal path and allows the probe to take the signal from the line.

**T-Connectors.** An impedance-matched T-connector (e.g. General Radio Type 874-TPD) can also be used, dividing the input signal into two equal signals for viewing and triggering. If an unmatched coaxial T-connector is used to obtain the triggering signal, the impedance transition may cause reflections in the system. Most of these reflections can usually be absorbed by placing attenuators in series with the signal.

**Coax Cables.** If a 50-ohm signal source that is time-related to the vertical input signal is available, it may be used as an external triggering signal. By selecting the length of the triggering signal cables with respect to the input signal cables, the triggering point may be adjusted as desired to shift the "time window" of the crt display. The delay provided by coax cables with polyethylene dielectric is about 1 nsec for each 8 inches of cable. If cables are used, however, keep them as short as possible.

If the triggering signal occurs slightly early with respect to the portion of the vertical signal to be viewed, the display can often be returned to the screen by setting the TIME POSITION RANGE switch to a higher numerical value and using the MAGNIFIER knob to return the TIME/CM switch to the desired sweep rate.

If the desired portion of the signal cannot be located on the screen by use of the TIME POSITION RANGE switch, triggering is occurring too early. In this case, the triggering signal should be delayed with coax cables. If any portion

**TABLE 2-2**  
Triggering Signal Guide

Input	Suggested Connections	Amplitude at Signal Source					
		1 mv	10 mv	100 mv	1 v	10 v	100 v
SIGNAL IN Connector	50 Ω Coax (GR) <sup>1 2</sup> -----			██████████			40 mv-2 v
	P6034 10× Probe -----				██████████		400 mv-20 v
	P6035 100× Probe -----					██████████	4 v-20 v
	P6035 100× Probe/Coupling capacitor -----					██████████	4 v-150 v
	P6032 Probe (10×) <sup>3</sup> -----				██████████		400 mv-2 v
	P6032 Probe (1000×) <sup>3</sup> -----						40 v-150 v
	50 Ω Coax (BNC)/Adapter <sup>1 2</sup> -----			██████████			40 mv-2 v
EXT TRIG Connector	50 Ω Coax (BNC) <sup>1 2</sup> -----		██████████				8 mv-200 mv
	CT-3/50 Ω Coax (BNC) <sup>4</sup> -----			██████████			40 mv-2 v
	VP-1/P6034 10× Probe/Adapter <sup>5</sup> -----				██████████		80 mv-4 v
	VP-1/P6035 100× Probe/Adapter <sup>5</sup> -----					██████████	800 mv-20 v
	VP-1/P6035/Coupling Cap./Adapter <sup>5</sup> -----					██████████	800 mv-40 v
	T-Connector/50 Ω coax (GR)/Adapter <sup>6</sup> -----			██████████			16 mv-400 mv
	50 Ω Coax (GR)/adapter <sup>1 2</sup> -----		██████████				8 mv-200 mv

**Tektronix Part Numbers of Suggested Connecting Devices**

CT-3 Current Takeoff .....	017-0060-00
VP-1 Voltage Pickoff .....	017-0073-00
2-nsec Coax Cable (GR) .....	017-0505-00
5-nsec Coax Cable (GR) .....	017-0502-00
10-nsec Coax Cable (GR) .....	017-0501-00
~50 Ω Coax Cable (BNC) .....	012-0057-00
P6032 Cathode-Follower Probe .....	010-0108-00
P6034 10× Probe (GR) .....	010-0110-00
P6035 100× Probe (GR) .....	010-0111-00
50 Ω Coupling Capacitor (GR) .....	017-0028-00

<sup>1</sup>With no attenuation. External attenuators may be used for larger signals.

<sup>2</sup>Use impedance-matching device if source impedance is other than 50 ohms.

<sup>3</sup>Minimum and maximum attenuation factors shown. Use other attenuators for intermediate amplitudes.

<sup>4</sup>CT-3 Current Takeoff inserted into 50-ohm system.

<sup>5</sup>VP-1 Voltage Pickoff inserted into 50-ohm system.

<sup>6</sup>Reduce reflections with T-attenuators.

## Operating Instructions—Type 1S1

of the signal is displayed on the crt screen, the proper amount of delay to be added or subtracted can be determined from the sweep rate of the display and the amount of displacement that the signal must be moved.

Advancing the trigger signal with respect to the vertical input signal may be accomplished either by using a pretrigger pulse generated before the vertical signal pulse, or by delaying the vertical signal with high-quality coax cable. If signal delay in excess of 60 nsec is required, the use of a Tektronix Type 113 Delay Cable is recommended.

Delaying the triggering signal may be done by inserting delay cables between the signal source and the EXT TRIG connector or by removing some delay cable from the vertical signal path. Connecting cables for the triggering signal may be RG-58A/U or RG-8A/U.

### Pretriggering

If a test device has a significant amount of signal delay, a pretrigger pulse may be used to advance the triggering signal to the Type 1S1. The time relationship between the pretrigger and the test pulse should be such that the pretrigger precedes the test pulse by less than one half the reading of the TIME POSITION RANGE scale to be used, minus the delay time of the test device. This positions the response signal on the crt when the TIME POSITION control is centered, and allows the display to be examined in detail.

If a pretrigger pulse generator is to be used for triggering when the response signal is being observed from a test device without significant delay, the pretrigger may have to be delayed up to 40 nsec in order to use the 50 nS time position range. Otherwise the triggering may occur before the response signal has reached the sampling gate. (All other time position ranges have enough positioning capability to overcome the time shift produced by the delay line.)

### Triggering Controls

Operation of the triggering controls depends on the frequency or repetition rate and the waveshape of the input triggering signal. Table 2-3 outlines the use of the TRIGGER SENSITIVITY and RECOVERY TIME controls with the TRIGGER SOURCE switch set to INT $\pm$  or EXT $\pm$  and an appropriate triggering signal applied.

For triggering signals from approximately 100 kc to 1 Gc, the trigger circuit recognizes either positive-going or negative-going excursions of the input triggering signal. The setting of the TRIGGER SOURCE switch determines whether the positive-going (+) or negative-going (—) excursion of the signal causes a trigger recognition to be made, and the TRIGGER SENSITIVITY control determines the level of the triggering signal that causes the recognition. The RECOVERY TIME control adjusts the rate at which the trigger circuit is allowed to recover and be rearmed.

**Table 2-3**

Use of Triggering Controls

Type of Triggering	Triggering Signal Frequency or Repetition Rate	Waveshape	Operation of Controls
Normal Triggered Operation (RECOVERY TIME not at SYNC)	Below 80 kc	Sine wave	1. Set RECOVERY TIME to any position, preferable counterclockwise but not to SYNC. 2. Adjust TRIGGER SENSITIVITY to trigger display at desired level.
		$\pm$ Pulse	
	80 kc to 20 Mc	Sine wave or $\pm$ Pulse	Either A or B: A. 1. Set RECOVERY TIME to any position, preferably counterclockwise but not to SYNC. 2. Adjust TRIGGER SENSITIVITY to trigger display at desired level. B. 1. Set TRIGGER SENSITIVITY to free run region (45° or more clockwise from midrange). 2. Adjust RECOVERY TIME to count down smoothly from triggering signal frequency.
SYNC Triggering (RECOVERY TIME control switched to SYNC)	20 Mc to 1 Gc	Sine wave or $\pm$ Pulse	1. Set RECOVERY TIME to SYNC position. 2. Adjust TRIGGER SENSITIVITY to synchronize circuit with triggering signal.

Normally a zero triggering level is obtained with the TRIGGER SENSITIVITY control set 45° clockwise from the midrange (straight up) position. When the TRIGGER SOURCE switch is set to the INT+ or EXT+ position, if the TRIGGER SENSITIVITY control is turned clockwise from the zero level position, the ac-coupled input triggering signal is moved in the positive direction with respect to the fixed triggering level of the circuit (see Fig. 2-9A and 2-9B). If the control is turned counterclockwise, the triggering signal is moved in a negative direction with respect to the triggering level (see Fig. 2-9C and 2-9D). Trigger recognitions will be made in Fig. 2-9A and 2-9C because the triggering signal passes through the triggering level. In Fig. 2-9B, the trigger will free run, since the input triggering signal is always more positive than the triggering level. In Fig. 2-9D, the trigger will be held off, since the triggering signal is always more negative than the triggering level. The trigger circuit is most sensitive to small signals when the TRIGGER SENSITIVITY control is set slightly counterclockwise from the zero triggering level position.

If the TRIGGER SOURCE switch is set to the INT— or EXT— position, the input triggering signal is inverted prior

to being connected to the trigger circuit. In this case, negative-going pulse signals are changed to positive-going signals, then the triggering operation is the same as previously described and trigger recognitions are made on negative-going excursions of the input signal.

The TRIGGER SENSITIVITY control determines the input triggering signal level that will cause the circuit to operate. The amplitude and duty factor of the input signal will determine the effective range of the control operation (approximately 200 mv when the signal is applied through the EXT TRIG connector, and 2 volts when applied by way of the SIGNAL IN connector). Normal triggering is accomplished by setting the TRIGGER SENSITIVITY control so that the trigger level coincides with the desired triggering level of the input signal.

The repetition rate of the trigger circuit is established primarily by the setting of the TIME POSITION RANGE switch and is adjusted by means of the RECOVERY TIME control. This holdoff period is designed to allow the fast ramp to operate and reset properly between triggering events. Mini-

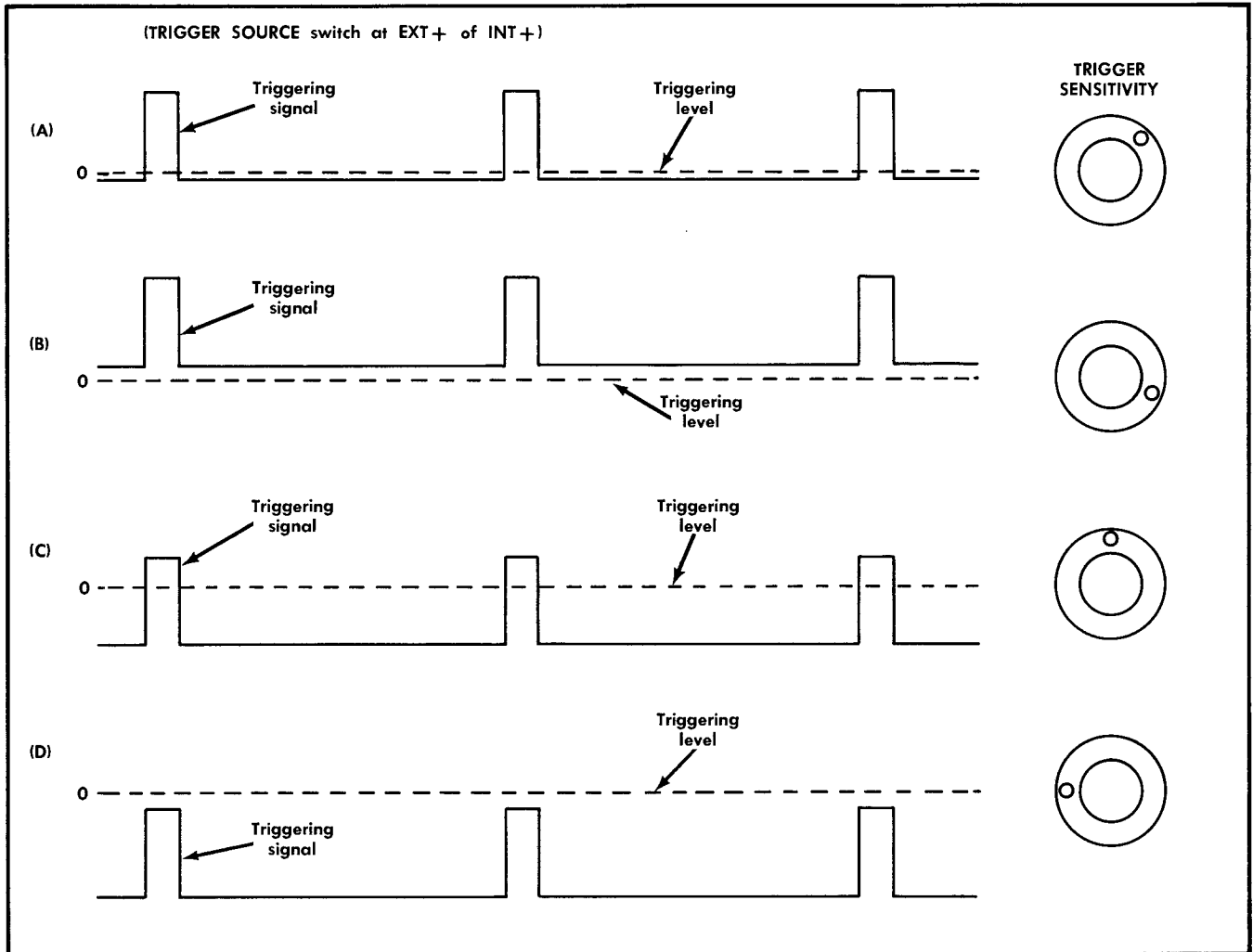

Fig. 2-9. Operation of the TRIGGER SENSITIVITY control, with an input pulse amplitude of about 100 mv external (or 1 volt internal) and a repetition rate below 80 kc (see text).



imum holdoff of the trigger circuit (for a given setting of the TIME POSITION RANGE switch) occurs with the RECOVERY TIME control set fully counterclockwise (but not switched to SYNC position). If the control is turned clockwise, the hold-off time of the circuit is increased and the maximum repetition rate is decreased. This control can change the repetition rate of the circuit by about 30% on any time position range, permitting the rate to be adjusted so that the trigger recognition circuit is armed between cycles of the input triggering signal. If recovery occurs while the input signal level is above the triggering level, an unstable display may result (see Fig. 2-10).

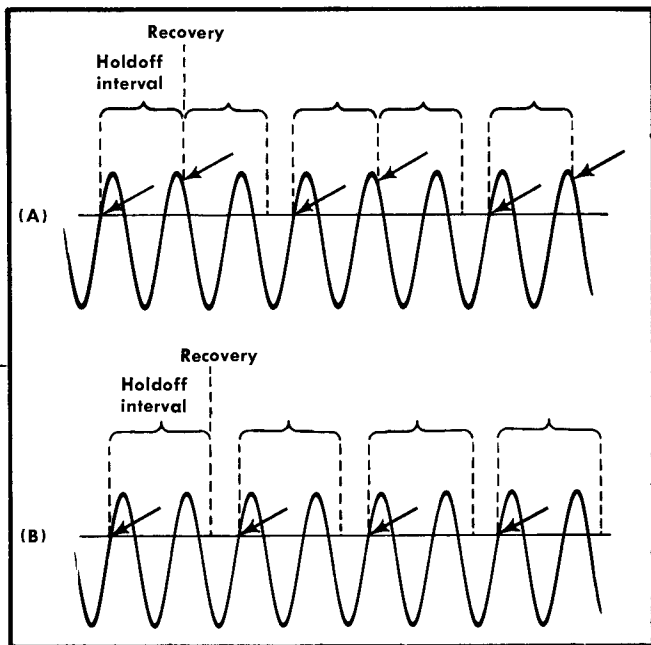

Fig. 2-10. Operation of the RECOVERY TIME control, illustrated with a 125-kc sine wave and 500  $\mu$ s time position range. Arrows indicate triggering points. (A) Trigger recovery occurs during wrong portion of cycle causing unstable triggering. (B) RECOVERY TIME control is adjusted so that recovery occurs between cycles and triggering takes place at the same point on the waveform each time.

For waveforms such as pulses, that have low duty factors, the RECOVERY TIME control is usually not needed unless the frequency of the input signal is nearly equal to the repetition rate of the holdoff circuit. For signals with medium or high duty factors, such as sine waves and square waves, use of the RECOVERY TIME control will usually improve the triggering stability. In this case, adjust the TRIGGER SENSITIVITY control to the desired level, then adjust the RECOVERY TIME control for a stable display.

**Free Run.** When the TRIGGER SENSITIVITY control is turned fully clockwise, the trigger circuit will normally free run at the maximum repetition rate of the holdoff circuit, unless the trigger recognition circuit synchronizes with the input triggering signal. This free run condition is normal with any signal up to 80 kc and many signals up to about 10 Mc. Above 10 Mc, however, if the signal excursion occurs just prior to the time that the circuit would be ready to free run (following the holdoff period), the circuit may

be triggered in synchronization with the signal. Thus synchronized triggering is possible with the TRIGGER SENSITIVITY control set in its free run region (45° or more clockwise from the midrange point). Slight adjustment of the RECOVERY TIME control or the TRIGGER SENSITIVITY control will then usually provide stable triggering.

**Normal Triggered Operation.** On input triggering signals up to the repetition rate of the trigger circuit (set by the TIME POSITION RANGE switch and the RECOVERY TIME control), one trigger occurs for each cycle of the input triggering signal when the TRIGGER SENSITIVITY control is set correctly. (This applies primarily to pulse triggering, since sine-wave triggering rolls off below about 100 kc.)

When the frequency of the input triggering signal is above the maximum repetition rate of the trigger circuit, trigger recognition takes place on the first cycle of the waveform following circuit recovery. Output pulses to the remainder of the system then occur at or slightly below the maximum repetition rate of the trigger circuit. In this triggering range, the RECOVERY TIME control is effective in adjusting the trigger circuit to recover between cycles of the input signal, to provide stable triggering.

**“SYNC” Triggering.** When the RECOVERY TIME control is switched to SYNC position, the trigger circuit operation is changed so that it will synchronize with signals of approximately 20 Mc and above. Basic operation of the trigger circuit is the same as for normal triggering, but with the RECOVERY TIME control set to a fixed position, only the TRIGGER SENSITIVITY control requires adjustment. The frequency of the synchronizing circuit is adjusted by the TRIGGER SENSITIVITY control to permit the circuit to synchronize with the input signal during the remaining period. Thus, when the circuit is ready to be triggered, the triggering occurs in synchronization with the input signal.

### Triggering Difficulties

The incorrect use of triggering controls and incorrect connections to the signal source are the most common causes of apparent triggering problems. Sometimes, however, the difficulty may result from the misadjustment of a calibration control or malfunction of a circuit component.

Always check switch and control settings and triggering signal input connections if an apparent problem occurs. Table 2-4 provides helpful information for alleviating certain possible triggering difficulties.

TABLE 2-4  
Possible Sources of Triggering Problems

Symptom	Suggestions
No sweep	Check that the DISPLAY MODE switch is at NORMAL position. Check that the SAMPLES/CM control is not at SWEEP OFF position. Check that the horizontal deflection patch cord is in place. Check that the trace is not positioned off the screen horizontally with the oscilloscope Horizontal Position control. Check that the trace is not positioned off

No Sweep (cont'd)	<p>screen vertically with the DC OFFSET control.</p> <p>Check that the TRIGGER SENSITIVITY control is set correctly.</p> <p>Check the CONTROL TD BIAS adjustment.</p> <p>Check the COMPARATOR LEVEL adjustment.</p>
Free-Running Sweep	<p>Check that the TRIGGER SOURCE switch is not at FREE RUN.</p> <p>Check that the TRIGGER SENSITIVITY control is set correctly.</p> <p>Check the CONTROL TD BIAS adjustment.</p> <p>Check the COMPARATOR LEVEL adjustment.</p>
No Triggering	<p>Check that the TRIGGER SOURCE switch is set to the correct source and correct slope.</p> <p>Check that the input signal amplitude is within the correct amplitude range for the source used (40 mv to 2 volts for internal; 8 mv to 200 mv for external).</p> <p>Check that the triggering signal frequency is within the proper triggering range (100 kc to 1 Gc for sine waves). Use fast-rise pulses from 10 cps to 100 kc (and up to 1 Gc).</p> <p>Check that the TRIGGER SENSITIVITY and RECOVERY TIME controls are set correctly for the particular signal frequency.</p> <p>Check the INT TRIG LEVEL adjustment.</p>
Display Jitter	<p>Check that the triggering signal amplitude is correct (see "No Triggering" above).</p> <p>Check that the triggering signal frequency is within the proper triggering range (see "No Triggering" above). Above 10 Mc, SYNC triggering may provide a more stable display.</p> <p>Check that the triggering signal rate of rise is fast enough (7 mv/<math>\mu</math>sec or faster for internal; 1 mv/<math>\mu</math>sec or faster for external).</p> <p>Check that the TRIGGER SENSITIVITY and RECOVERY TIME controls are set correctly for the particular signal frequency.</p> <p>Check the COMPARATOR LEVEL adjustment.</p>
Triggering Cannot Be Held Off	<p>Check that the input triggering signal amplitude is not too large for the source used (see "No Triggering" above).</p> <p>Check the INT TRIG LEVEL adjustment.</p>

## OPERATING INFORMATION

### Selecting Display Dot Density

Selection of the dot density that will produce the best display depends on both the repetition rate of the input triggering signal, and the maximum repetition rate of the trigger circuit on the time position range being used. If the input repetition rate is low, or if the trigger holdoff period is long, the trace progresses very slowly across the crt screen when the dot density is high. On the other hand, if the dot

density is set lower than necessary, some of the display information may be unnecessarily lost between samples. In general, the best setting of the SAMPLES/CM control is one that produces the highest dot density possible with a reasonable display repetition rate. If there are fast-rise portions on the waveform, however, it may be advantageous to set the SAMPLES/CM control for a more dense display in order to observe the detail of the waveform.

If smoothing is used for reducing display noise, the dot density must be sufficiently high to allow the sampling circuits to follow the input signal closely. If the shape of the displayed waveform changes as the SAMPLES/CM control is turned, the display is being modified by the combination of smoothing and low dot density. In this case, the control should be set for the best compromise between repetition rate and dot density that does not change the display waveshape significantly from that present with a high dot density.

### Selecting Equivalent Sweep Rate

The various combinations of TIME/CM switch settings and TIME POSITION RANGE indicator settings permit a considerable amount of flexibility in selecting the best sweep rate and the best time positioning range for the particular waveform display. See "Time Magnification" below for the use of the magnification controls.

Since the display produced by the Type 1S1 is made up of samples taken from different cycles of the input waveform, the sweep rate indicated by the TIME/CM switch is not the actual display rate, but is rather the "equivalent-time" sweep rate. This means that the TIME/CM switch is calibrated in time units that would be appropriate if the display were a continuous real-time presentation. This permits making accurate time measurements in the sub-nanosecond range directly from the sampling display. If the dot density is set quite high, the actual sweep rate of the display may be very slow, even though a very fast equivalent-time sweep rate is used.

It is usually best to use the fastest sweep rate that is commensurate with the waveform to be observed. This permits high resolution when making time measurements, since the portion of the waveform to be measured is spread out over several cm. A fast sweep rate also provides the highest possible display repetition rate (for a given dot density), since the holdoff period of the trigger circuit is shorter on the time position ranges available at the faster sweep rates. The TIME POSITION and FINE controls can then be used to position the desired portion of the display on the screen for observation.

If a sweep rate slower than 50  $\mu$ sec/cm is required, a conventional pramplifier plug-in unit may be substituted for the Type 1S1, or the oscilloscope and Type 1S1 can be set for real-time sampling operation, as described later in this section.

### Time Magnification

A direct-reading time magnifier is built into the TIME/CM switch, permitting the range of the time positioning controls to be increased by factors of 10 and 100, and permitting up to  $\times 100$  magnification of a display from sweep rates from 50  $\mu$ sec/cm to 1 nsec/cm. Horizontal dot spacing of the display is not changed by the time magnification. This

means that the number of samples taken per unit equivalent time is increased by the magnification factor. When the display is magnified, expansion occurs about the left edge of the crt screen, regardless of the TIME POSITION control setting.

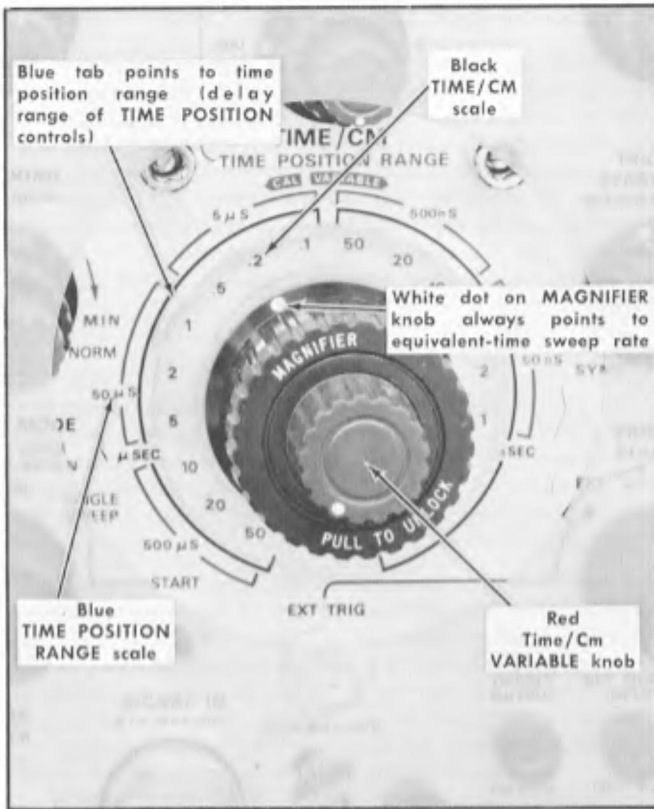

Fig. 2-11. Use of the time magnifier for expanding the display. As shown, the unit is set for  $\times 5$  magnification with a display sweep rate of  $0.2 \mu\text{sec}/\text{cm}$  and a crt "time window" positioning range of  $50 \mu\text{sec}$ .

Fig. 2-11 shows the magnification controls. To use the controls for magnifying a display:

1. With the TIME/CM MAGNIFIER knob and the TIME POSITION RANGE switch engaged, set the sweep rate to the desired unmagnified display. (White dot and blue tab should be together.)
2. Position the display with the TIME POSITION and FINE controls so the portion of interest is near the left edge of the screen.
3. Pull out the gray MAGNIFIER knob and turn it clockwise for the desired amount of magnification. Magnification up to  $\times 100$  is available in six steps. If the MAGNIFIER knob is turned clockwise farther than the  $\times 100$  position, it will pull the TIME POSITION RANGE switch with it.
4. Reposition the FINE control slightly, if necessary.

Up to 3 times more time magnification (uncalibrated) with no decrease in dot density can be obtained with the Time/Cm VARIABLE control. Display expansion with the VARIABLE control also takes place about the left edge of the screen.

## Use of DC Offset

The front-panel DC OFFSET control may be used for cancelling the effect of a dc voltage (up to  $\pm 1$  volt) in the presence of a low-amplitude signal, and may be used in conjunction with the OFFSET OUTPUT jack for making accurate dc voltage measurements of the input waveform. See "Basic Applications" later in this section for the use of dc offset for measuring voltages.

In addition to providing display positioning, the use of dc offset for cancelling dc voltages may be used to make particular dc level of a waveform remain stationary on the crt screen while the mVOLTS/CM switch is changed from one setting to another (see Fig. 2-12).

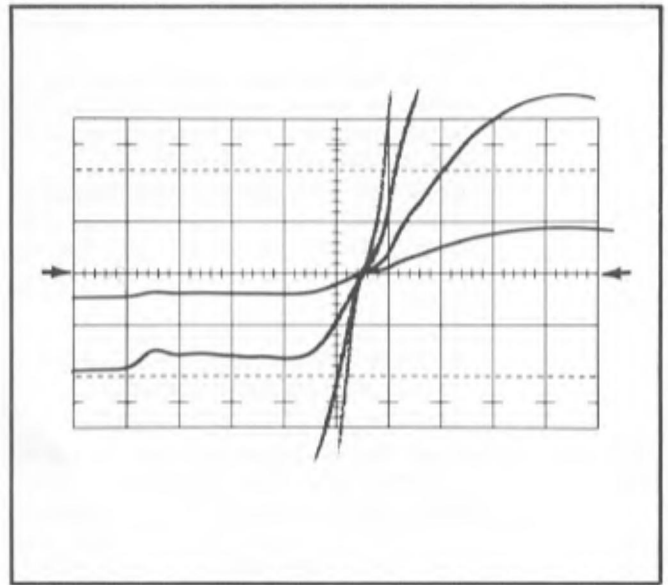

Fig. 2-12. Multiple-exposure photograph showing use of DC OFFSET control for holding display at a particular dc level while vertical deflection factor is changed.

To adjust the DC OFFSET control for observation of a particular level of the waveform, proceed as follows:

1. Obtain a display of the input waveform in the usual manner.
2. Set the mVOLTS/CM switch to the lowest deflection factor (highest sensitivity) to be used.
3. With the DC OFFSET control, move the selected level of the display to the graticule centerline.
4. Switch the mVOLTS/CM to the highest deflection factor to be used.
5. With the VERT POSITION control, center the selected level on the graticule centerline again.
6. Repeat steps 2 through 5 for the final adjustment.

Now leave the DC OFFSET control in this final position while making observations of the display. The selected level will stay at the same vertical position on the crt screen while the mVOLTS/CM switch is rotated between its various posi-

tions. Use only the VERT POSITION control for positioning the display vertically on the crt screen.

### Use of Smoothing

Time and amplitude noise may sometimes be objectionable when operating at minimum deflection factors or maximum sweep rates. The SMOOTHING control may be used to reduce random noise, when necessary, by decreasing the gain of the sampling feedback loop. Fig. 2-13 shows the advantage of using smoothing when observing a low-amplitude signal.

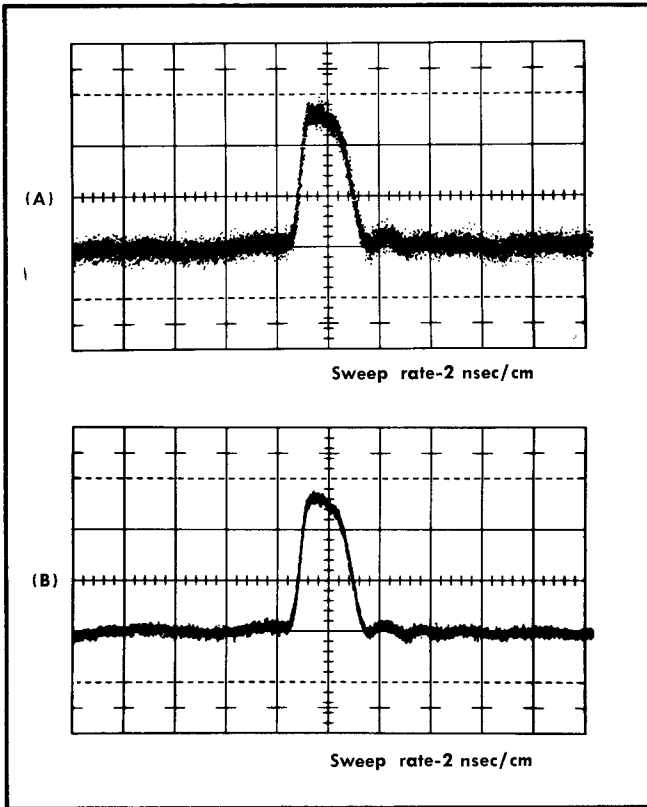

Fig. 2-13. Use of the SMOOTHING control for decreasing display noise when viewing a low-amplitude signal. Displayed waveform is a 5-mv 2-nsec pulse. (A) SMOOTHING control at NORM; (B) SMOOTHING control counterclockwise.

Normally the SMOOTHING control will not significantly affect the risetime of the display if the dot density is sufficient. If, however, the waveform shape is affected when the SMOOTHING control is adjusted, a compromise must be made between smoothing and dot density (see "Selecting Display Dot Density" above). Fig. 2-14 illustrates the effect produced by using smoothing when the dot density is too low.

### "False" Displays

Due to the nature of the sampling display, it is sometimes possible to obtain an apparent waveform on the crt screen that is not a true representation of the input signal, with

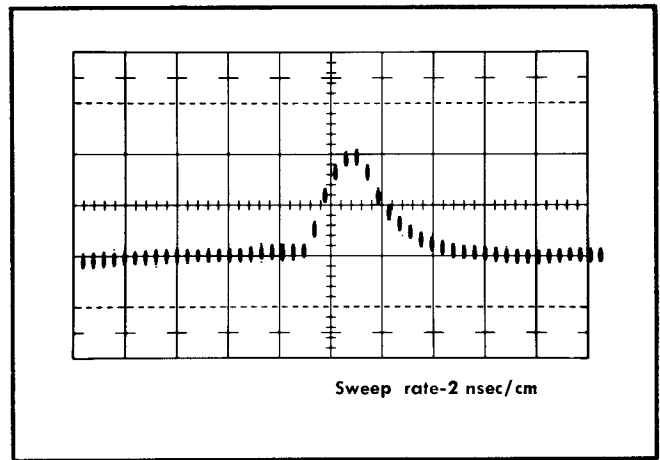

Fig. 2-14. Typical waveform illustrating the use of smoothing in conjunction with a low dot density. The waveform is the same 5-mv 2-nsec pulse shown in Fig. 2-13. The distortion can be removed by either increasing the dot density or decreasing the amount of smoothing.

respect to equivalent time, if the sampling rate is very close to a sub-multiple of the signal frequency. This type of display appears as a waveform of a much lower frequency than the input signal and is caused by sampling at such a slow rate that the samples are taken on widely-separated portions of the signal. Each sample represents the correct amplitude at the instant of sampling, but not enough samples are taken to trace out the correct waveform.

In the Type 1S1, this type of display is rarely obtained because of the continuously variable selection of sampling dot density with the SAMPLES/CM control. A false display can be detected by merely changing the dot density. The timing of the waveform should not change. If the display is found to be false, increase the sweep with the TIME/CM switch until the individual cycles of the waveform are displayed and the apparent timing does not change with display dot density (see Fig. 2-15).

### Single Sweep

A single-sweep presentation of the crt display may be obtained with the DISPLAY MODE switch set to SINGLE SWEEP position. This feature may be used for viewing or photographing a waveform on a slow-moving sweep or a waveform that changes shape over a relatively short period of time.

To display a single sweep of the crt:

1. Set up the triggering controls with the DISPLAY MODE switch set to NORMAL.
2. Set the DISPLAY MODE switch to SINGLE SWEEP. The sweep will be held off following the completion of the current sweep.
3. Press the START button. The sweep circuit is then armed and the sweep will occur immediately if the triggering information is still arriving.
4. Release the START button. This allows the single-sweep circuit to be reset. (The START button must be released to

## Operating Instructions—Type 1S1

its normal position before another single-sweep presentation can be obtained.)

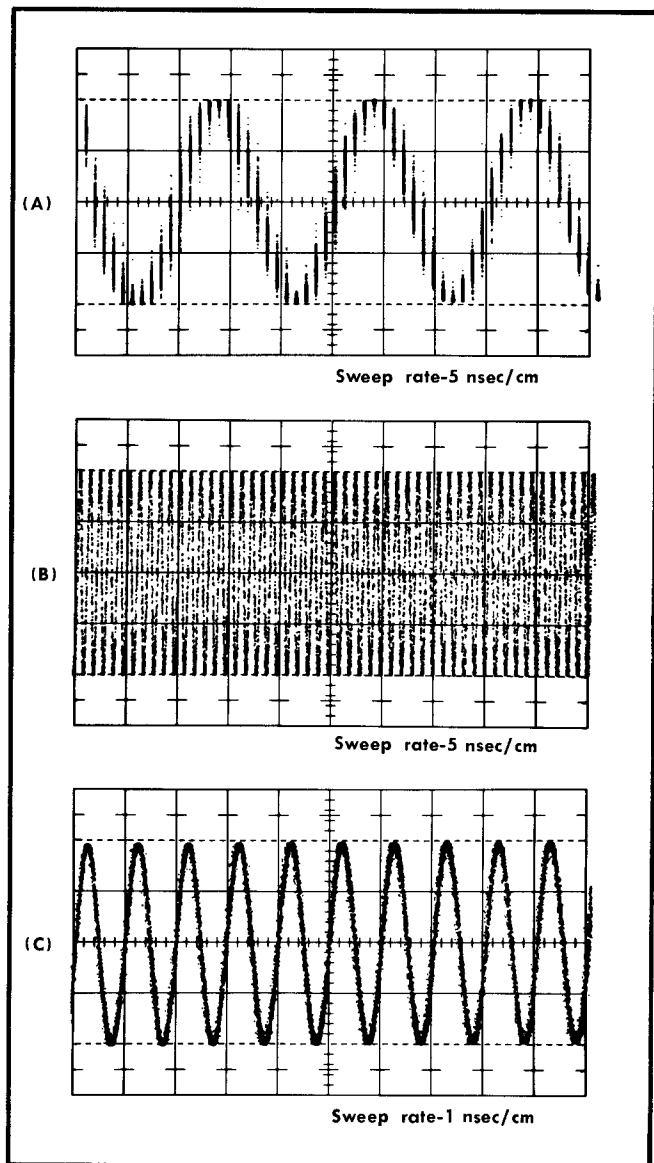

Fig. 2-15. Typical "false" sampling display showing the means of detecting and eliminating the "false" presentation. (A) 1-Gc sine wave viewed at 5 nsec/cm and a low dot density; (B) same 1-Gc waveform viewed at a high dot density; (C) waveform viewed at 1 nsec/cm sweep rate, showing true frequency of signal.

### External Sweep and Manual Scan

When the DISPLAY MODE switch is set to either EXT HORIZ or MAN, the staircase generator no longer provides a staircase waveform for driving the horizontal deflection. If an external voltage signal is applied to the EXT HORIZ INPUT jack with the DISPLAY MODE switch at EXT HORIZ, the external signal will produce horizontal scanning of the crt display, but the display will still be calibrated in equivalent time as indicated by the TIME/CM switch. Similarly, if the MANUAL SCAN control is turned while the DISPLAY

MODE switch is at MAN position, an internal voltage in the Type 1S1 will provide horizontal scanning of the equivalent-time crt display.

Slow scanning with either an externally-applied signal or the MANUAL SCAN control is convenient at times for driving an external recording device or for observing some particular portion of the waveform at a high dot density.

Since all circuits other than the staircase must still be operated once for each sample to be displayed, the other display and triggering controls should be set up in the usual manner. The dot density of the display is set by the rate of scanning, rather than by the setting of the SAMPLES/CM control. Because of this, it is usually best to use a linear waveform such as a sawtooth or triangle for scanning the display, in order to provide a uniform dot density. The Sweep Output or Sawtooth Output jack on the oscilloscope front panel is a convenient source for the scanning voltage. The more slowly the display is scanned, the denser the trace will be.

The EXT HORIZ ATTEN control adjusts the attenuation of an externally-applied deflection voltage. The attenuation factor is variable from 1 volt/cm with the control fully clockwise to greater than 16 volts/cm with the control fully counterclockwise. This permits full scanning of the crt with signals of from 10 volts to 150 volts in amplitude (150 volts is the maximum permissible at the EXT HORIZ INPUT).

## REAL-TIME SAMPLING OPERATION

### General Information

If sweep rates are needed below the slowest equivalent-time rate provided by the Type 1S1 TIME/CM switch, the Type 1S1 and the oscilloscope may be operated in such a way as to produce "real-time" sampling displays. Real-time sampling is a method of operation in which the samples are taken at a constant rate from a relatively low frequency signal (Dc to 5 kc) and displayed at a sweep rate determined by the oscilloscope Time/Cm switch. Thus, the samples are taken continuously along the waveform, rather than one sample from each cycle of the waveform, and the displayed series of dots follows the actual shape of the input signal waveform.

In real-time sampling operation, the oscilloscope provides triggering of the display, in addition to providing the real-time sweep rate. The triggering circuit of the Type 1S1 is operated in free run to provide sampling pulses. To provide the fastest sampling repetition rate, the Type 1S1 TIME POSITION RANGE switch should be set to one of the 500 nS or 50 nS positions. The staircase generator of the Type 1S1 must be disabled for real-time sampling operation to prevent periodic blanking during the staircase retrace. This is done by setting the Type 1S1 SAMPLES/CM control to the SWEEP OFF position.

### Advantages

The primary advantage of real-time sampling is that it extends the operation of the oscilloscope down to low frequencies without having to use a different plug-in unit. In addition, the Type 1S1 provides greater vertical sensitivity than many non-sampling plug-in units, though its maximum

sensitivity can be used only if the signal source impedance is 50 ohms. Passive sampling probes or cathode-follower probes, with 10X minimum attenuation, may be used if the source impedance is other than 50 ohms. Another advantage of real-time sampling with the Type 1S1 is that the passive probes may be conveniently extended from the oscilloscope by relatively long lengths of 50-ohm coax cable without changing the input characteristics of the Type 1S1.

### Sweep Rates

The range of sweep rates available for use in real-time sampling is from the slowest rate available with the oscilloscope to about 0.1 msec/cm. At the crossover point from real-time to equivalent-time sampling, the display dots begin to have significant horizontal dimension, due to their duration in real time. This may be seen in Fig. 2-16 which shows a 5-kc square wave in equivalent-time sampling and real-time sampling displays. (This is one sweep rate beyond the practical limit of real-time sampling.) At sweep rates of 2 msec/cm and slower, the display dots are essentially continuous and provide a presentation that can be compared quite favorably with that obtained with a non-sampling plug-in unit.

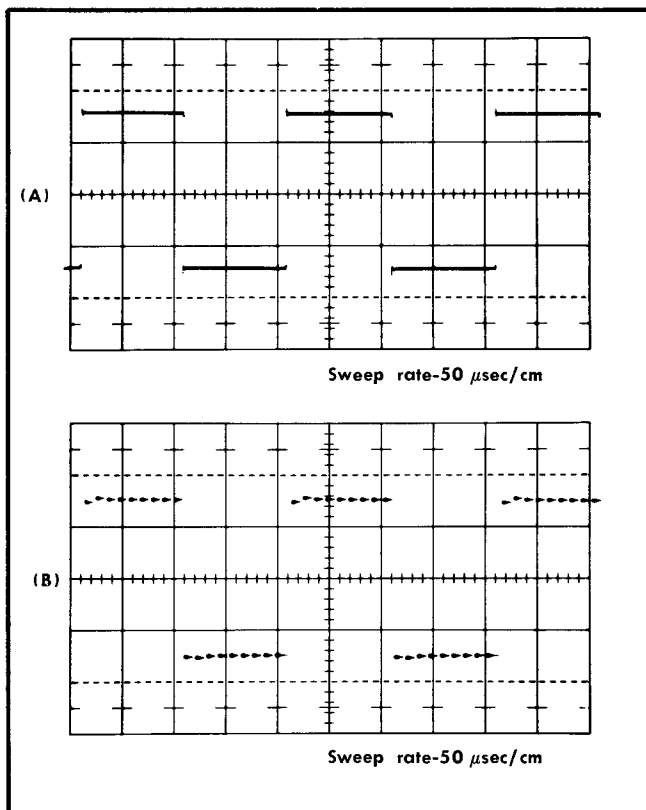

Fig. 2-16. Crt display of a 5-kc square wave showing comparison between equivalent-time sampling (A) and real-time sampling (B), just past the sweep-rate limit of real-time sampling (see text).

### Signal Coupling

The input signal may be applied to SIGNAL IN connector through 50-ohm coaxial cables and attenuators, passive

sampling probes or cathode-follower probes. For input signals with amplitudes above approximately 16 volts, a cathode-follower probe should be used, since dc-coupled passive sampling probes cannot be used above this voltage level, and ac-coupling of the probes does not pass signals at these frequencies.

### Triggering Sources

Since the oscilloscope triggering circuitry is used, the normal triggering sources available through the oscilloscope are used. The triggering signal may be obtained either internally from the oscilloscope vertical amplifier or power-line signal, or externally through the oscilloscope external trigger input.

### Procedure

To set up the Type 1S1 and oscilloscope for displaying signals with the real time method of operation:

1. Set the Type 1S1 controls as follows:

TRIGGER SOURCE	FREE RUN
TIME/CM	Any position utilizing the 50 nS or 500 nS time position range
SAMPLES/CM	SWEEP OFF
mVOLTS/CM and VARIABLE	Adjust for adequate display amplitude
VERT POSITION and DC OFFSET	Adjust to position trace on crt

2. Set the oscilloscope Horizontal Display switch to one of the internal time-base positions (e.g. Time Base A).
3. Apply an input signal within the amplitude limits of the SIGNAL IN connector (maximum  $\pm 2$  volts). Use an attenuator probe or coaxial attenuators if the signal amplitude is greater than this.
4. Trigger the display with the oscilloscope triggering controls. For very low frequencies, use dc trigger coupling, as selected by the oscilloscope Trigger Mode or Coupling switch. For power-line frequency input signals, use line triggering.

Fig. 2-17 shows a comparison between a real-time sampling display of a line frequency signal obtained with the Type 1S1 and a conventional display of the same signal obtained with a non-sampling plug-in unit. (The signal was taken from the lead supplying power to the graticule lights of the oscilloscope.)

## BASIC APPLICATIONS

### General Information

The displayed waveform on the oscilloscope screen is normally a plot of voltage per unit equivalent time. The calibrated deflection factors of the Type 1S1 permit the sampling system to be used for making accurate voltage and time measurements of the input signal.

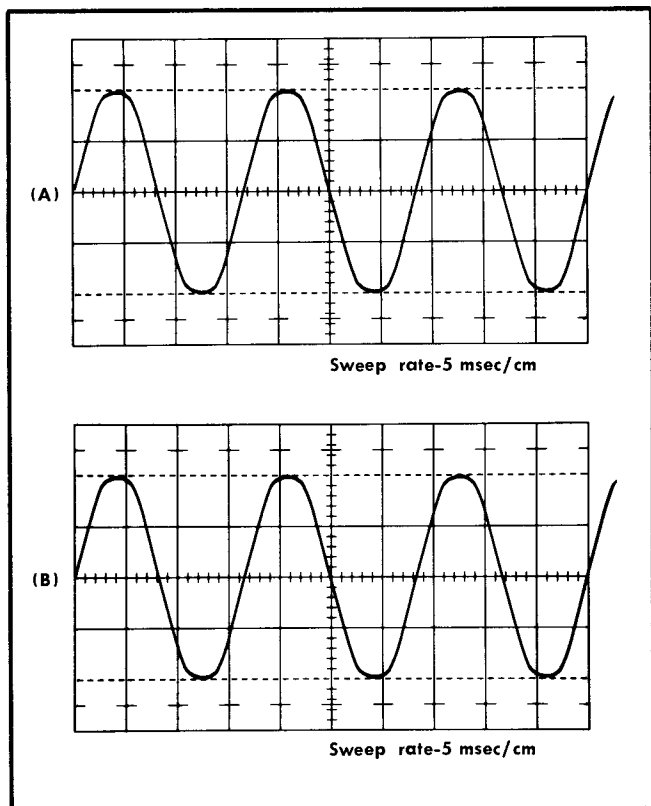

Fig. 2-17. Crt displays showing comparison between real-time sampling and non-sampling presentations of a 60 cps waveform. (A) Waveform obtained with Type 151; (B) Waveform obtained with non-sampling plug-in unit.

The displayed waveform on the crt screen of the oscilloscope is a plot of voltage per unit equivalent time. Since the Type 151 has calibrated deflection factors both vertically and horizontally, the sampling system can be used for making accurate voltage and time measurements of the vertical input signal. Because of the fast risetime and nanosecond sweep rates available, it is able to make measurements of fast-rise pulses, and may therefore be used in pulse-testing applications.

### VOLTAGE MEASUREMENTS

Vertical displacement of the crt trace is directly proportional to the voltage at the SIGNAL IN connector of the Type 151. The amount of displacement for any given voltage may be selected with the mVOLTS/CM switch. To provide adequate resolution for making a measurement, set the mVOLTS/CM switch so the display spans a large portion of the graticule.

#### Voltage-Difference Measurement from Display

The ac component of a waveform may be measured in terms of the peak-to-peak value or the voltage difference between any two points on the display. In many cases, either ac or dc coupling can be used for connecting the vertical input signal. In some applications, however, it may

be necessary to use ac coupling to prevent the dc component from deflecting the trace off the crt screen.

To make a voltage-difference measurement between two points on a display, use the following procedure:

1. Use the crt graticule to measure the vertical deflection in centimeters and fractions of centimeters between the two points on the display. Be sure the mVolts/CM VARIABLE control is in CAL (detent) position.
2. Multiply the amount of vertical deflection by the numerical setting of the mVOLTS/CM switch, and by the attenuation factor if an attenuator or probe is used. This product is the voltage difference between the two points measured. For a peak-to-peak measurement, this is the ac signal amplitude.

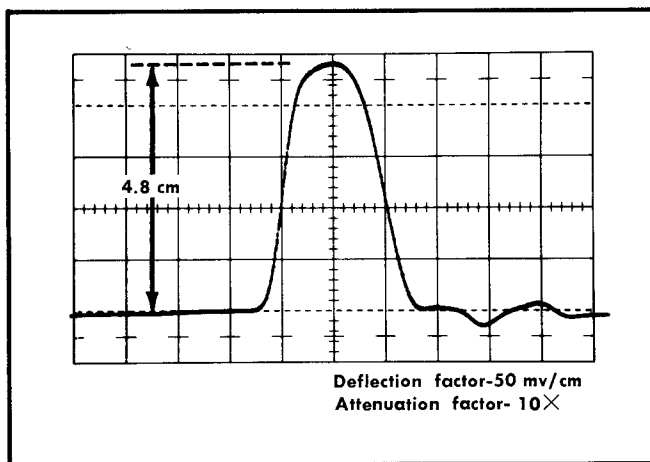

Fig. 2-18. Voltage measurement from display.  
Example:  $4.8 \text{ cm} \times 50 \text{ mv/cm} \times 10\text{X} = 2.4 \text{ v}$ .

As an example, Fig. 2-18 shows a waveform with 4.8 divisions of vertical deflection between two points of interest (the baseline and the peak), with the mVOLTS/CM switch at 50. The signal amplitude is therefore 240 mv at the SIGNAL IN connector. Assuming there is a 10X attenuator between the signal source and the SIGNAL IN connector, the voltage at the signal source then is 2400 mv or 2.4 volts.

#### Dc Voltage Measurement from Display

The instantaneous (dc) voltage of a displayed waveform is measured from some voltage reference level such as chassis ground.

To measure the dc voltage level of a signal:

1. Before connecting the input signal, free run the crt trace and position it at one of the horizontal graticule lines for a zero-volt dc reference level. The graticule line should be selected on the basis of polarity and amplitude of the applied signal. Make no further adjustments of the VERT POSITION and DC OFFSET controls while making subsequent measurements.
2. Connect the input signal.



3. Measure the voltage as described above, using the established zero-volt reference level as the point from which to make all measurements.

If the applied signal has a relatively high dc level, the zero-volt level and the input signal may be so far apart that only one will be in the graticule viewing area. In this case, use the DC offset method of voltage measurement as described next.

### DC Offset Voltage Measurement

The DC OFFSET control and the voltage available at the OFFSET OUTPUT jack can be used to make accurate voltage measurements of the input signal, whether or not the deflection factor of the Type 1S1 is calibrated.

Use the following procedure to make a measurement:

1. Obtain the desired sampling display through normal operating procedures.
2. Position the bottom of the waveform (or other desired reference portion) to the graticule centerline with the VERT POSITION and/or DC OFFSET control.
3. Measure the voltage at the OFFSET OUTPUT with an accurate high-impedance voltmeter or a monitor oscilloscope. This voltage is 10 times the applied offset voltage.
4. Using only the DC OFFSET control, position the top of the waveform (or other level to be compared) to the graticule centerline.
5. Again measure the OFFSET OUTPUT voltage.
6. Determine the voltage difference between the two measurements. If the voltage polarity has reversed, add the two measurements.
7. Divide the measured voltage difference by 10 to obtain the voltage difference at the SIGNAL IN connector. If the input signal path includes an attenuator, multiply the input signal voltage by the attenuation factor to obtain the voltage difference at the signal source.

## TIME MEASUREMENTS

The calibrated equivalent-time sweep rates of the Type 1S1 make any horizontal distance on the crt screen represent a specific interval of time. Thus the time lapse between any two events on an input signal can be measured directly from the waveform displayed on the crt screen. The sweep rate most convenient for measuring the input signal can be selected with the Type 1S1 TIME/CM switch. Set the sweep rate so the portion of the waveform containing the points of interest is spread over several cm of the graticule.

### Time Interval Measurement

Basic sweep accuracy of the Type 1S1 is  $\pm 3\%$  when the oscilloscope horizontal deflection factor is set to 1 volt/cm. Increased accuracy of time measurements can be obtained by checking the timing of the particular sweep rate to be used.

To make a time measurement between two points on a displayed waveform:

1. Measure the horizontal distance in centimeters and fractions of centimeters between the two points on the waveform. Be sure the Time/CM VARIABLE control is in CAL (counterclockwise detent) position.
2. Multiply the number of cm of horizontal deflection by the sweep rate indicated on the Type 1S1 TIME/CM switch.

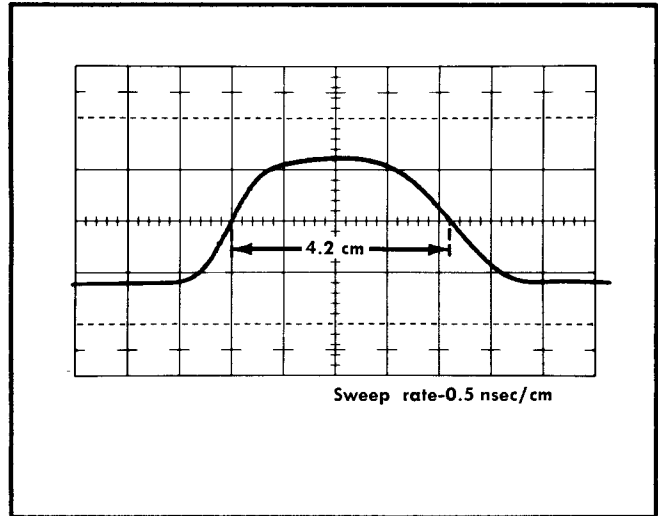

Fig. 2-19. Time interval measurement.  
Example:  $4.2 \text{ cm} \times 0.5 \text{ nsec/cm} = 2.1 \text{ nsec}$ .

Fig. 2-19 illustrates an example of a time interval measurement. The horizontal deflection of 4.2 cm is multiplied by the sweep rate of 0.5 nsec/cm to obtain a time interval of 2.1 nsec.

### Time Comparison Measurement

To make a time-comparison measurement between points on two different waveforms, it is necessary to use an external triggering signal for the time reference. The two input signals must bear a frequency relationship to each other and to the triggering signal.

1. Connect one of the input signals to the SIGNAL IN connector.
2. Connect the triggering signal to the EXT TRIG connector.
3. Set the TRIGGER SOURCE switch to EXT ( $\pm$ ) and trigger the display. Do not readjust the triggering controls until after the time comparison measurement has been made.
4. Adjust the Type 1S1 TIME POSITION control to position the point of interest on the waveform at some vertical reference line (e.g. the vertical centerline). Now do not readjust the TIME POSITION control until after the measurement has been made.
5. Remove the first input signal and connect the second signal. If the time relationship that is of interest is at the signal source, use the same input cable or probe or use another cable or probe that provides exactly the same amount of time delay.

## Operating Instructions—Type 151

6. Measure the horizontal distance between the point of interest on the second waveform and the vertical reference line obtained with the first waveform.

7. Determine the time interval between the two points in the manner described previously.

Fig. 2-20 is a double-exposure photograph illustrating the measurement of time comparison between points on two waveforms. In the example, the horizontal deflection of 6.28 cm multiplied by the sweep rate of 5 nsec/cm gives a time difference of 31.4 nsec. Since the time window starts at the left edge of the crt screen, the 50% level of the waveform to the left in the display occurs 31.4 nsec earlier in time than the 50% level of the waveform to the right.

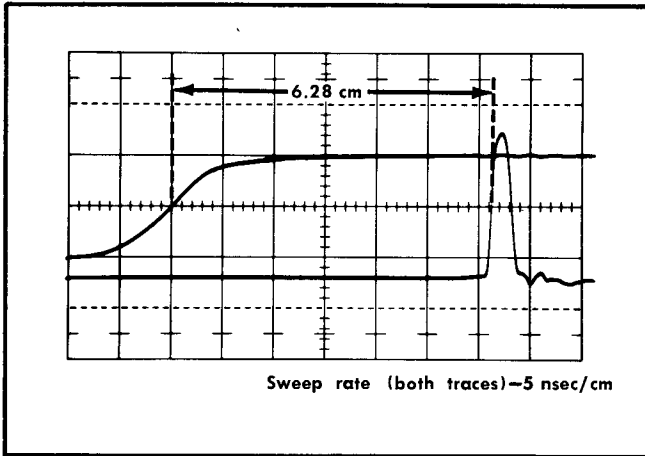

Fig. 2-20. Double-exposure of crt display for making time-comparison measurement between points on two different signals. Example:  $6.28 \text{ cm} \times 5 \text{ nsec/cm} = 31.4 \text{ nsec}$ .

### Risetime Measurement

The risetime of a pulse or signal is measured with the time-interval method. Unless otherwise specified, the risetime is measured between the 10% and 90% levels of the signal rise. Use the following procedure:

1. Set the TIME/CM switch so the rise will cover several cm horizontally. Leave the Time/Cm VARIABLE control at CAL position.
2. With the TIME POSITION control, position the pulse rise near the center of the crt screen.
3. Set the mVOLTS/CM switch and mVolts/Cm VARIABLE control to produce some even number of centimeters of vertical deflection.
4. Measure the horizontal distance between the 10% and 90% levels on the pulse rise. Table 2-5 gives the vertical deflection measurement between the 10% and 90% levels.

TABLE 2-5  
Risetime Deflection Guide

Total Cm of Deflection	Deflection Between 10% and 90% Points
4 cm	3.2 cm
5 cm	4.0 cm
6 cm	4.8 cm

For example, if the horizontal distance between the 10% and 90% points is 4.8 cm (see Fig. 2-21), and the sweep rate is 0.1 nsec/cm, the risetime of the pulse is equal to 4.8 cm multiplied by 0.1 nsec/cm, or 0.48 nsec (480 psec).

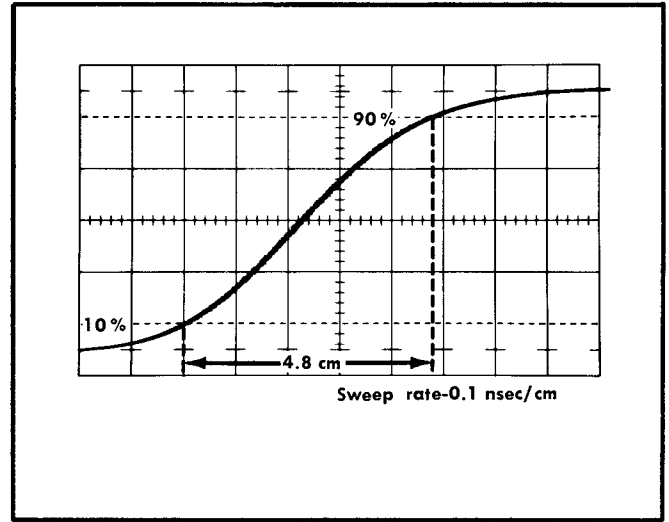

Fig. 2-21. Risetime measurement. Example:  $4.8 \text{ cm} \times 0.1 \text{ nsec/cm} = 0.48 \text{ nsec}$ , or 480 psec.

### Frequency Measurement

Since the frequency of any repetitive signal is equal to the reciprocal of its period (time interval of 1 cycle), the frequency can be calculated directly from the time interval of one cycle. If, for example, the period of a repetitive waveform is measured to be 105 nsec (see Fig. 2-22), the frequency of the signal is  $1/105 \text{ nsec}$ , or 9.5 Mc.

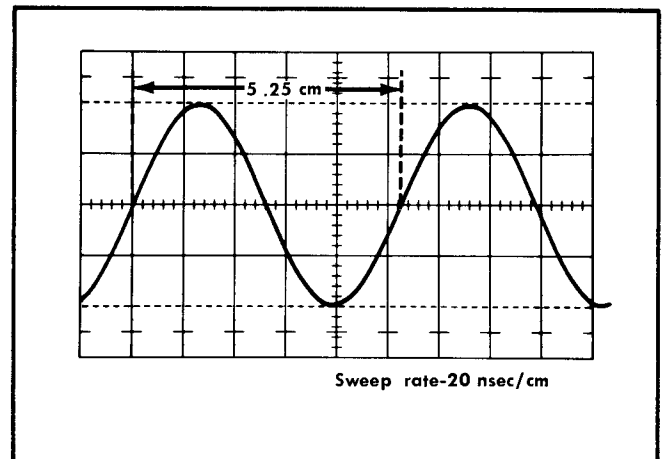

Fig. 2-22. Frequency measurement using relation  $f = 1/\text{period}$ . Example:  $5.25 \text{ cm} \times 20 \text{ nsec/cm} = 105 \text{ nsec}$ .

$$\frac{1}{105 \text{ nsec}} = 9.5 \times 10^6 = 9.5 \text{ Mc}$$

Another method of determining frequency that is sometimes easier and faster to use is obtained by dividing the average number of cycles displayed per cm by the sweep rate of the display (see Fig. 2-23). To use this method, determine the frequency as follows:

1. Set the Type 151 TIME/CM switch to display several cycles of the waveform on the crt screen. Be sure the Time/Cm VARIABLE control is in CAL (detent) position.
2. Count the precise number of cycles displayed over the 10 cm of the graticule.
3. Divide the number of cycles by 10 to obtain the average number of cycles/cm.
4. Divide the resulting number of cycles/cm by the sweep rate, indicated by the Type 151 TIME/CM switch, to obtain the frequency.

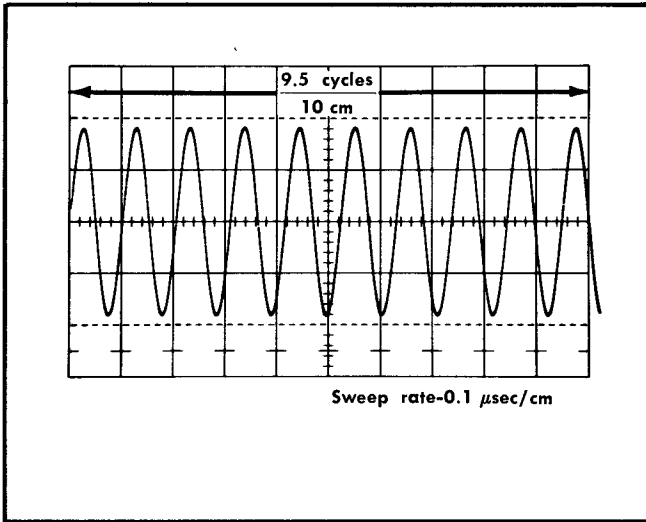

Fig. 2-23. Frequency measurement using the average number of cycles/cm.

Example:  $\frac{9.5 \text{ cycles}/10 \text{ cm}}{0.1 \mu\text{sec}/\text{cm}} = 9.5 \text{ cycles}/\mu\text{sec}$ , or 9.5 Mc

For example, with a sweep rate of  $0.1 \mu\text{sec}/\text{cm}$ , if the number of cycles displayed is exactly 9.5, divide the 9.5 cycles by 10 cm, then divide that quotient by the  $0.1 \mu\text{sec}/\text{cm}$  sweep rate, to obtain a frequency of 9.5 Mc.

### Phase Measurement

Phase comparison between two sinusoidal waveforms of the same frequency can be made by a method nearly identical to the time-comparison method just described. For phase measurements, however, it is usually more convenient to first calibrate the display in degrees of phase angle per cm of horizontal deflection. For instance, if the display sweep rate is adjusted so that one cycle of the waveform ( $360^\circ$ ) covers exactly 8 cm of the graticule, the display is then calibrated at  $45^\circ/\text{cm}$ . (The use of  $45^\circ/\text{cm}$  is suggested to provide a large display and also to calibrate the display at 1 quadrant of phase for every 2 cm.)

To retain the exact relationship between the signals at their sources, they should be applied to the SIGNAL IN connector through a signal path that provides the same delay for each signal. The external triggering signal may be taken from one of the signals at the source or may be provided by some other time-related signal.

The relative amplitude of the signals does not affect the phase measurement as long as each signal is vertically centered on the horizontal centerline. However, it is often easier to measure the phase difference if the display amplitudes have been adjusted to be the same.

To measure the phase angle between two signals:

1. Connect one input signal to the SIGNAL IN connector.
2. Connect the triggering signal to the EXT TRIG connector.
3. Set the TRIGGER SOURCE switch to EXT ( $\pm$ ) and trigger the display. Do not readjust the triggering controls again until after the phase measurement has been made.
4. Set the TIME/CM switch to display approximately 2 cycles of the waveform.
5. Adjust the Time/Cm VARIABLE control so that one cycle of the waveform covers exactly 8 cm of the graticule (to calibrate the sweep at  $45^\circ/\text{cm}$ ). At the same time, adjust the TIME POSITION control so the waveform rise crosses the horizontal centerline at the 1-cm and 9-cm vertical graticule lines (see Fig. 2-24).
6. Remove the first signal and connect the second input signal.
7. Determine the horizontal deflection in cm and fractions of cm between the rise of the second waveform and the closest vertical reference line (either the 1-cm or 9-cm vertical line).
8. Multiply the cm of deflection by the calibrated sweep rate ( $45^\circ/\text{cm}$ ) to obtain the phase angle in degrees.

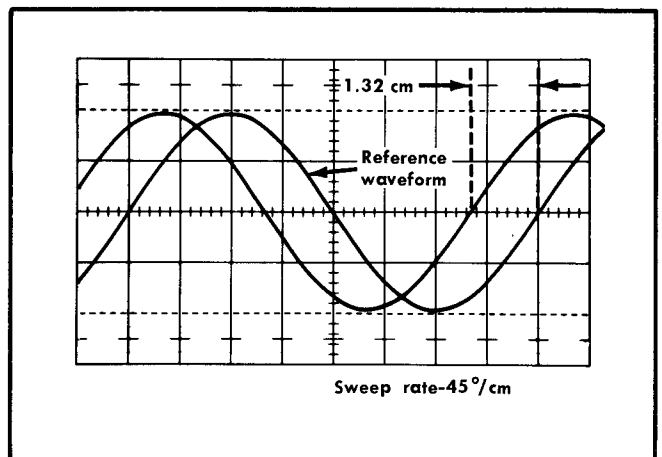

Fig. 2-24. Double exposure photograph of crt display used for making a phase-angle measurement between two signals (see text).

Example:  $1.32 \text{ cm} \times 45^\circ/\text{cm} = 59.5^\circ$ .

For example, Fig. 2-24 shows phase comparison between two 10-Mc sine waves. The horizontal deflection of 1.32 cm multiplied by  $45^\circ/\text{cm}$  gives a phase difference of  $59.5^\circ$ . The first (reference) waveform in this example lags the second waveform by  $59.5^\circ$ , since it lies to the right in the display.

## ANALOG-RECORDER OPERATION

The output horizontal and vertical sampling signals available at the Type 1S1 HORIZ OUTPUT and VERT OUTPUT jacks can be used for driving an external recording device. The Type 1S1 thus permits the recording of waveforms with picosecond risetimes or gigacycle frequencies.

To use the Type 1S1 in this manner:

1. Set up the equivalent-time sampling display in the usual manner with the Type 1S1 and oscilloscope.
2. Set the oscilloscope Time/Cm switch to 10 mSec.
3. Free run the oscilloscope time-base generator to provide a sawtooth output waveform. (Leave the oscilloscope set for external horizontal deflection.)
4. Connect a patch cord from the oscilloscope Sawtooth Output jack to the Type 1S1 EXT HORIZ INPUT jack.
5. Set the Type 1S1 DISPLAY MODE switch to EXT HORIZ.
6. Adjust the EXT HORIZ ATTEN control for a sweep length of approximately 10 cm.
7. Set the oscilloscope Time/Cm switch for the desired X-axis rate of the recording device. Most oscilloscopes that will accommodate the Type 1S1 provide sweep rates down to 5 sec/cm or 50 sec/sweep. If slower rates are required, an external sweep voltage (up to 150 volts in amplitude) may be applied to the EXT HORIZ INPUT jack.
8. Connect the Type 1S1 HORIZ OUTPUT jack to the horizontal-axis input of the recorder. (The patch cord to the oscilloscope may be left in place to monitor the display.)
9. Connect the Type 1S1 VERT OUTPUT jack to the vertical-axis input of the recorder.

## PULSE TESTING

When used with a fast-rise pulse generator, the Type 1S1 can be used for making observations and measurements of delay line transit time, impedance of an unknown source, or characteristics of response signals from a test device.

### Basic Precautions

Certain precautions should always be observed when connecting a pulse signal to a test device or to the Type 1S1:

1. Use high-quality coax cables and connectors for all signal connections.
2. Make sure that all connections are tight and that all connectors are tightly assembled.
3. Keep signal cables as short as possible to preserve the signal quality.
4. Use attenuators as needed to limit the signal amplitude into the sampling system and other sensitive circuits.
5. Use terminations and impedance-matching devices to suit the application.

### Risetime Characteristics

When using a fast-rise pulse to determine the risetime of a test device, the risetimes of the pulse and of the Type 1S1 may sometimes have to be taken into consideration. As a

general rule, if the risetime of the test device is at least 10 times as long as the combined risetime of the input pulse and the Type 1S1 and input cables, the error introduced into the measurement by the testing system will not be more than 1% and therefore can be considered negligible.

If, however, the risetime of the test device is less than 10 times as long as the combined risetime of the testing system, the observed risetime will not give a true measurement of the test device risetime. In this case, the actual risetime of the test device will have to be determined from a determination of the effects produced by the various components making up the system. Normally the overall risetime of the system can be found by taking the square root of the sum of the squares of the individual risetimes. Conversely, the risetime of the test device can be found from the same relationship if all of the risetimes in the system are known except that of the test device.

### Impedance Measurement

As a signal travels down a transmission line, each time it encounters a mismatch, or different impedance, a reflection is generated and sent back along the line to the source. The amplitude and polarity of the reflection are determined by the value of the encountered impedance in relation to the characteristic impedance of the cable. If the mismatch impedance is higher than that of the line, the reflection will be of the same polarity as the applied signal; if it is lower than that of the line, the reflection will be of opposite polarity.

The reflected signal is added to or subtracted from the amplitude of the pulse if it returns to the source before the pulse has ended. Thus, for a cable with an open end (no termination), the impedance is infinite and the pulse amplitude would be doubled. For a cable with a shorted end, the impedance is zero and the pulse would be canceled.

Measurement of an encountered impedance can be made either by observing the change in amplitude of the applied pulse or by measuring the reflection alone after separating the reflection from the pulse with delay cables. The amplitude of the reflection ( $\rho$ ), expressed as a decimal fraction of the applied pulse amplitude, is related to the characteristic impedance of the system ( $Z_0$ ) and to the load impedance ( $Z_L$ ) in the following manner:

$$\rho = \frac{Z_L - Z_0}{Z_L + Z_0}; \text{ Therefore: } Z_L = Z_0 \frac{1 + \rho}{1 - \rho}$$

The load impedance can thus be calculated from the amplitude of the reflection.

For example, consider the following situation: a +2-volt pulse is sent down a 50-ohm cable and encounters an unknown impedance; the reflection returns to the pulse source after the pulse has ended and the resulting amplitude is +500 mv. This is the reflection amplitude; therefore,  $\rho = +500/+2000 = +0.25$

$$\text{and } Z_L = 50 \frac{1.00 + 0.25}{1.00 - 0.25} = 83.3 \text{ ohms}$$

By connecting the pulse test system to the SIGNAL IN connector of the Type 1S1, this reflection signal can be observed on the oscilloscope screen, and the impedance measurement can be calculated directly from the display amplitude.

# SECTION 3

## CIRCUIT DESCRIPTION

The Type 1S1 provides both the vertical deflection signal and the horizontal deflection voltage to the display oscilloscope to produce the crt presentation. This section of the manual describes the circuitry that enables the Type 1S1 to sample the vertical input signal and to generate the necessary deflection voltages. The basic equivalent-time sampling process is discussed first, then the circuitry of the Type 1S1 is analyzed in more detail. Refer to the block diagram in Fig. 3-1 during the discussion of the basic sampling process.

### EQUIVALENT-TIME SAMPLING

Sampling oscilloscopes are designed primarily to be used for viewing high-frequency or fast-rise repetitive waveforms. Most modern sampling systems accomplish this by taking samples from many different cycles of the input signal and reconstructing the waveform in "equivalent time" on the crt screen.

The vertical system of the Type 1S1 utilizes a sampling gate that takes quick samples of the input signal, amplifiers that process the samples, and a memory circuit that applies the sampling voltage signal to the oscilloscope vertical deflection system then retains the previous level until a new

sample is taken. The horizontal sweep is produced by a staircase voltage that advances one step each time a sample is to be displayed. One excursion of the input signal causes the trigger circuit to initiate one cycle of the sampling process and produce one dot of the display.

The cycle starts when the trigger circuit recognizes an excursion of the triggering signal and unclamps the fast ramp generator which produces a rundown voltage to be compared to the staircase feedback voltage. The resulting comparison pulse is sent to the vertical system as a sampling-drive pulse and to the staircase circuit as a staircase-advance pulse.

The sampling circuit then takes a sample of the input signal while the staircase generator advances one step. The sampling memory output is applied to the vertical amplifier and the new staircase output level is applied to the horizontal deflection system of the oscilloscope. As soon as the sample has been taken, a dot is displayed on the crt screen at a level proportional to the input signal level at the instant it was sampled. The dot then remains stationary on the screen until another sample is taken.

Each subsequent triggering event initiates the same sequence of events, but since the staircase feedback voltage

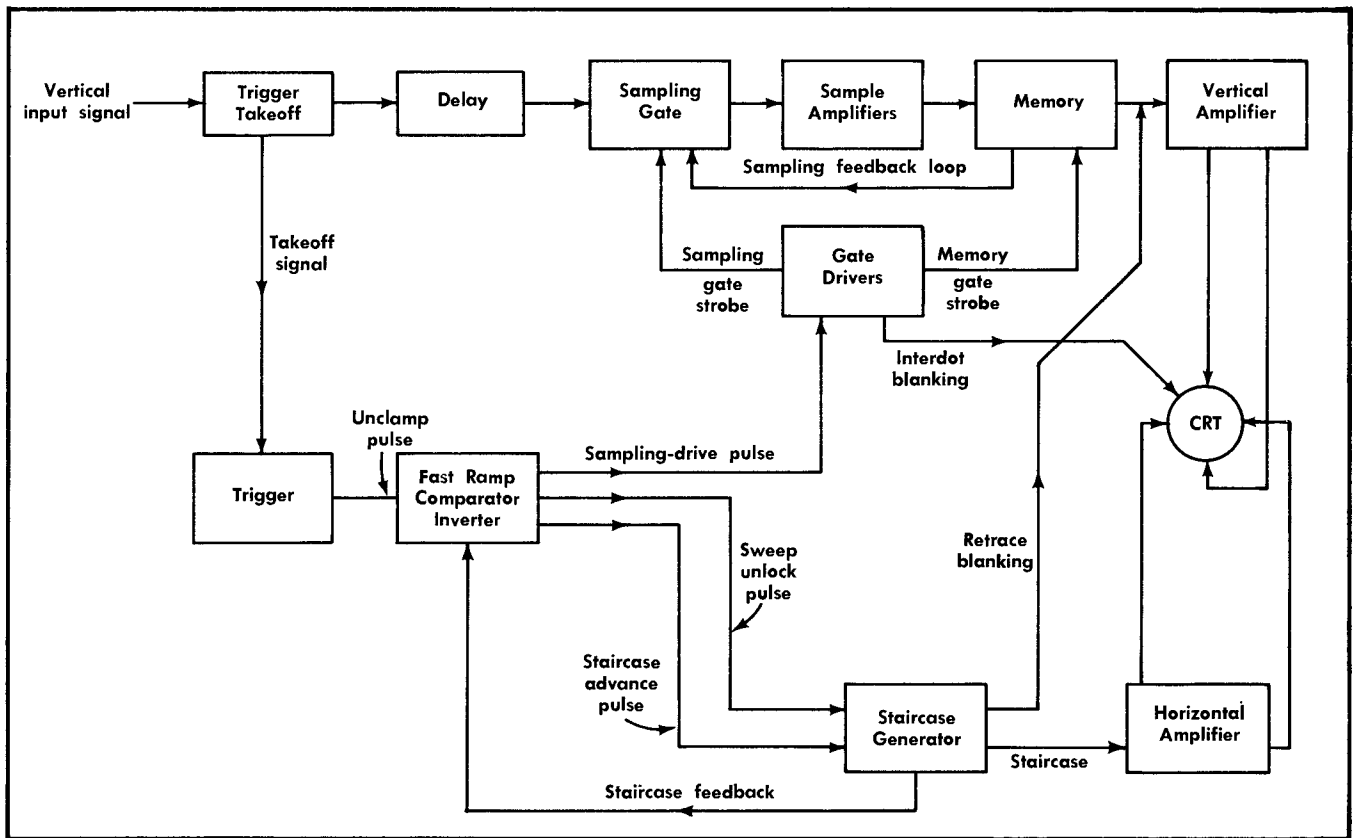

Fig. 3-1. Basic equivalent-time sampling system used in the Type 1S1.

## Circuit Description—Type 1S1

moves down one step each time, the fast ramp has to run slightly farther each time before a comparison pulse is produced. In this way the sampling operation is delayed by successively longer intervals and the samples are taken successively later along the waveform with respect to the triggering point. Each time a sample is taken, the crt is blanked momentarily while the dot position on the crt moves horizontally by one increment. Since the vertical channel is an error-sensing circuit, the vertical position of the dot changes only if the input voltage level changes between samples.

Fig. 3-2 illustrates the development of an equivalent-time display from a repetitive square-wave signal. Note that the sampling operation is triggered each time at the same point on the triggering waveform, but that the sample is taken progressively later on the waveform, due to the longer delay between the triggering event and the sampling event. No two samples are taken from the same cycle of the input waveform.

## CIRCUIT ANALYSIS

The Type 1S1 circuitry consists of a horizontal channel and a vertical channel, each of which may be subdivided into several basic circuits. The fold-out block diagram at the rear of this manual shows each basic circuit as a block and indicates the functional relationships existing between the circuits. Refer to this block diagram for the basic operation of the system and refer to the detailed block diagrams in the text and the particular schematic diagrams at the rear of the manual for the detailed analysis of each circuit. The following descriptions are arranged in essentially the same sequence as the schematic diagrams.

## VERTICAL SYSTEM

The vertical system of the Type 1S1 uses a balanced-bridge error-correction type of sampling operation, providing vertical deflection voltages for the display oscilloscope. It has an internal trigger takeoff circuit which may be used to start the trigger circuit operation. The input signal is delayed approximately 45 nsec after the trigger takeoff to allow the trigger circuit to begin the sampling cycle before the signal has reached the sampling gate diode bridge. A zero-order-hold memory is used to remember the value of the previous sample.

The sampling repetition rate ranges from approximately 50 cps to about 80 kc, depending on the repetition rate of the triggering signal and the recovery time of the trigger holdoff circuit. If a rate slower than about 50 cps is used, the memory output may drift, and memory "dot slash" may be seen. The maximum rate of 80 kc allows sufficient time for the sampling unit to pass a sample and recover before another sample is taken. Above 80 kc, countdown of the triggering signal occurs automatically.

## Cycle of Operation

The vertical input signal is applied through a 50-ohm coaxial connector and passes through the trigger takeoff and a 50-ohm coaxial delay cable to the sampling gate. The trigger takeoff transformer takes off a small portion of the input signal and sends it to the trigger circuit to be used for starting the operation of the sampling cycle.

After being triggered, the horizontal circuitry sends a sampling-drive pulse to the blocking oscillator in the vertical system. The blocking oscillator then pulses the snap-off circuit with a fast pulse and the memory gate driver with a slower pulse. Short push pull pulses from the snap-off

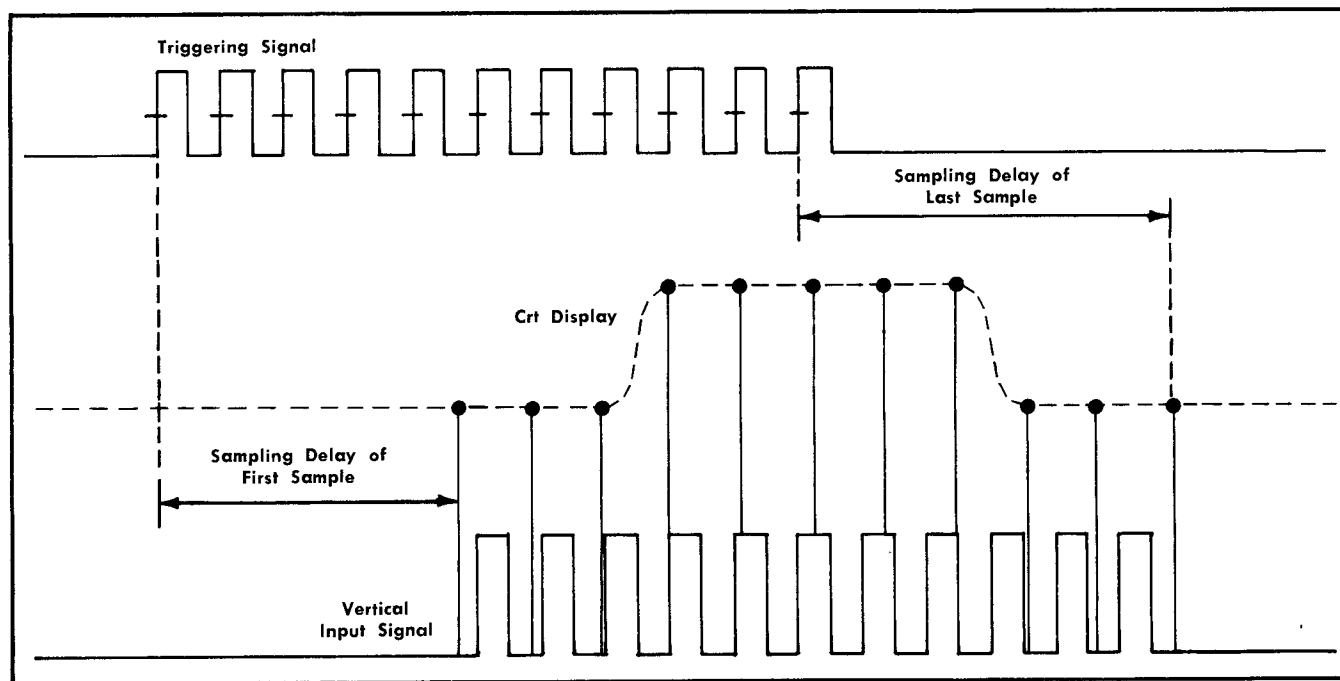

Fig. 3-2. Formation of crt display by equivalent-time sampling process.

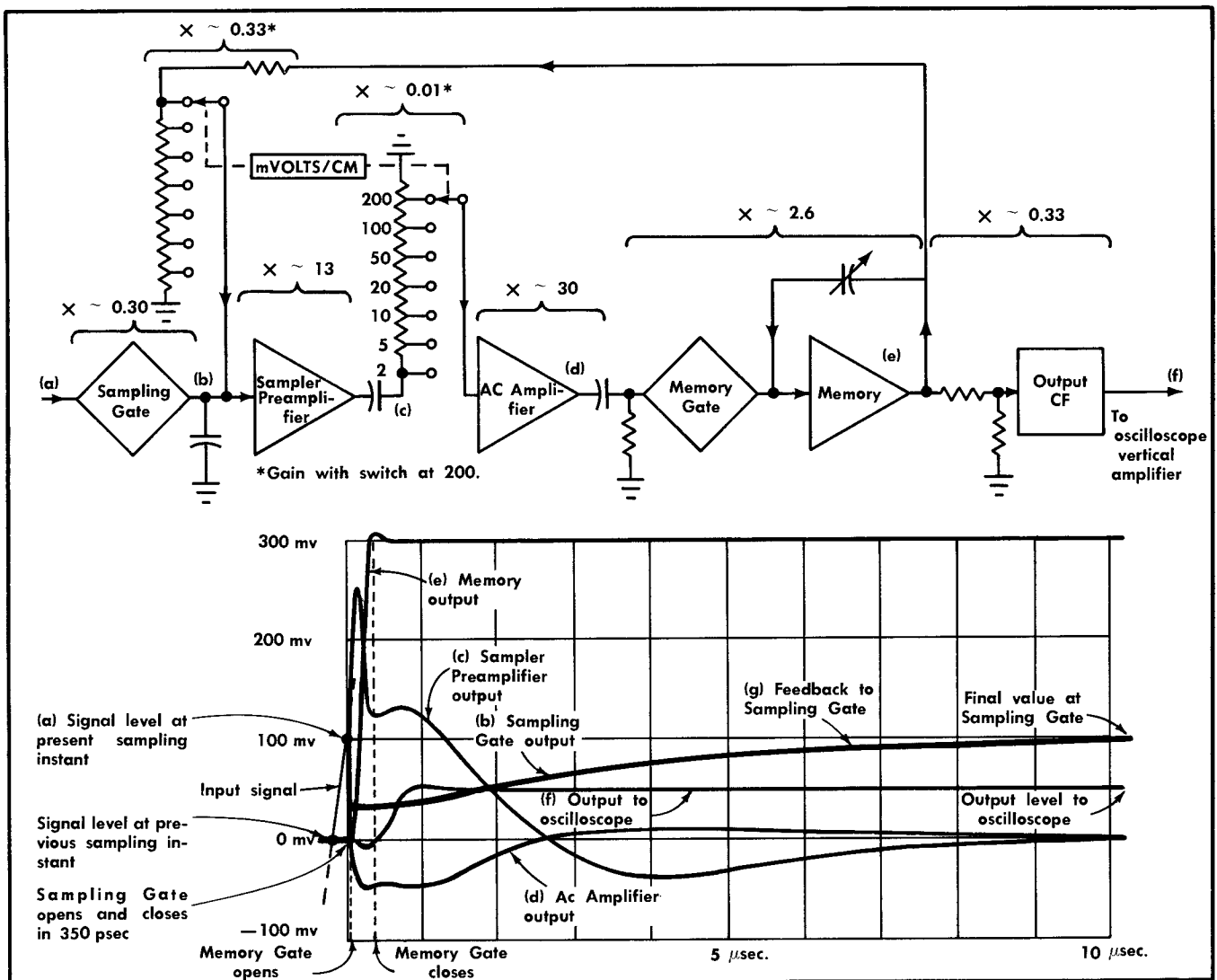

Fig. 3-3. A single sample signal traced through the feedback loop (see text).

circuit are applied to the sampling gate, strobing the gate into conduction for a brief period, during which the input signal is passed through the sampling gate. The signal attempts to charge up the circuit capacitance to the level of the input signal at the moment of sampling, but the strobe pulses end and the gate stops passing signal before the capacitance has had time to charge completely.

The small error-correction sample pulse that was passed by the sampling gate is amplified by the sampler preamplifier, then passed through a portion of the mVOLTS/CM switch and sent to the ac amplifier to be amplified and inverted again.

By the time the signal pulse reaches the memory gate, the gate has been pulsed into conduction by the memory gate driver, so the sample is passed from the ac amplifier to the memory circuit. The memory reinverts the signal and stores the value of the pulse on the memory capacitor. The memory output level is the attenuated and applied through the output cathode follower to the vertical amplifier of the display oscilloscope.

A portion of the memory output signal is also sent back through a positive feedback loop to the sampling bridge. Since the memory gate stops conducting immediately after the sample pulse has passed, the feedback signal is not regenerated through the main signal path. The signal in the feedback loop brings the charge on the input circuit capacitance up to the input signal voltage level that was present at the instant it was sampled. The vertical system is then ready for the next sample to be initiated by the next trigger pulse. Fig. 3-3 traces a single sample pulse through the sampling channel, showing the effect of feedback. In the illustration, the mVOLTS/CM switch is set to 200.

(a) The input signal is at a level of 100 mV at the time the sample is taken, having risen from zero volts, the level of the previous sample.

(b) A very fast rise is seen at the output of the sampling gate while the gate is forward biased. The pulse amplitude reaches about 30 millivolts before the gate stops passing signal, then the level remains nearly constant while the amplifiers process the sample.

## Circuit Description—Type 1S1

(c) The sampler preamplifier amplifies the step by an overall factor of about 13, thus applying an effective amplitude of about 390 mv to the attenuator.

(d) With the mVOLTS/CM switch set at 200, as in the illustration, the error-correction signal is attenuated by a factor of 100, then is amplified by the ac amplifier by a factor of about 30 to produce an inverted output of about 117 mv. The voltage at the input to the memory does not change by this amount, however, due to the fact that the memory is a high gain amplifier with negative feedback that holds its input nearly stationary.

(e) Circuit gain of the memory is about 2.6, producing an output amplitude of 300 mv in the illustration. The memory gate then stops conducting and the charge on the memory capacitor holds the output level at 300 mv.

(f) The output is applied through an attenuator to the output cathode follower. Attenuation is approximately 3 in this circuit, reducing the 300 mv memory output to 100 mv to be applied to the oscilloscope vertical amplifier.

(g) The memory output is also applied through the feedback attenuator, where it is attenuated by a factor of 3, to the sampler. Thus the input to the sampler preamplifier is brought up to the initial 100 mv present at the input at the instant of sampling. The system is then ready to take another sample.

Each subsequent sample is taken at a later point on the waveform, as determined by the staircase generator. Thus the signal through the vertical system, from the sampler to the oscilloscope, is a series of pulses, each of which is proportional to the change in signal level between sampling events. The series of level correction signals from the Type 1S1 is sent to the oscilloscope vertical circuitry where it positions the displayed dot vertically on the crt screen to draw out the input signal as a series of dots. If the signal level does not change between samples, no signals pass through the circuitry, and a straight line of dots is presented.

Since the vertical circuitry of the oscilloscope requires 100 mv of signal amplitude from the sampling unit for each centimeter of vertical deflection on the crt, the output deflection factor of the Type 1S1 must remain constant at 100 mv/cm with respect to the input signal. To maintain this relationship and still be able to change the input deflection factor for viewing both large and small signals, the output gain of the vertical system and the gain of the sample-pulse amplifiers must be varied in opposite directions. These two functions are performed simultaneously by the action of the two attenuators operated by the front-panel mVOLTS/CM switch.

### SAMPLER

The sampler schematic diagram shows the input to the vertical system, the trigger takeoff, the delay line and input termination, the sampling gate, the sampler preamplifier and the ac amplifier in the signal channel, and also the blocking oscillator, the snap-off circuit, the memory gate driver and the interdot blanking amplifier. The detailed block diagram of the sampler is shown in Fig. 3-4.

### Blocking Oscillator

A positive-going sampling-drive pulse is received from

the comparator circuit through C81. The pulse is inverted by transformer T80 and applied as a negative-going pulse to the base of blocking oscillator Q80. Between pulses, Q80 is turned off, with both the base and the emitter tied to ground. The  $-19$  volts at its collector sets Q80 a few volts short of its avalanche point, so that it is ready to saturate as soon as it is turned on.

The negative-going pulse at the base of Q80 turns the transistor on rapidly, sending a fast positive-going current pulse through C85 to the snap-off circuit. Essentially no current flows in T82 until after the snap-off diode has been "swept out". When the current source through C85 has been depleted, current begins to flow in T82. The positive-going voltage pulse at the collector of Q80 is then inverted by T82 and sent to the memory gate driver to start the operation of that circuit. The negative-going output of T82 is also fed back through D80 to the base of Q80 to sustain the blocking oscillator action.

Following saturation, the normal blocking oscillator backswing occurs, turning off Q80. Diode D80 prevents the backswing from driving the base of Q80 above ground. Diode D82 is forward biased by the backswing and quickly depletes the energy stored in T82, returning it quickly to the quiescent state.

### Snap-Off Circuit

Between sampling-drive pulses, current-storage diode (snap-off diode) D87 is turned on with a forward bias current. SNAP-OFF CURRENT adjustment R85 adjusts the current through D87, and thus adjusts the stored charge in the diode. As the positive-going current pulse is applied from the blocking oscillator through C85, the stored charge is pulled from the snap-off diode. As soon as the charge is depleted, D87 becomes a high impedance and the resulting fast voltage transition that appears at the cathode of the diode is sent through C87 and a 50-ohm transmission line to T88. The push-pull output pulse from T88 is applied through C88 and C89 to the corners of the sampling gate bridge to strobe the gate into conduction for approximately 340 psec. Resistors R88 and R89 terminate the 50-ohm transmission line.

### Sampling Channel Input

The SIGNAL IN connector on the front panel of the Type 1S1 is a 50-ohm GR Type 874 connector that assures relatively uniform input characteristics up to 1 Gc and provides a quick-mate input system. The characteristic impedance of the input is within 2% of 50 ohms at all frequencies from dc to 1 Gc.

### Trigger Takeoff

The trigger takeoff circuit is located immediately following the SIGNAL IN connector. It consists of a ferrite core transformer (T1) which takes off about 1% of the input signal energy and sends it through the TRIGGER SOURCE switch to the trigger circuit for internal triggering. Transformer T1 delivers an ac output voltage signal equal to about 1/7th the voltage of the vertical input signal, over the range from approximately 100 kc to about 1 Gc.



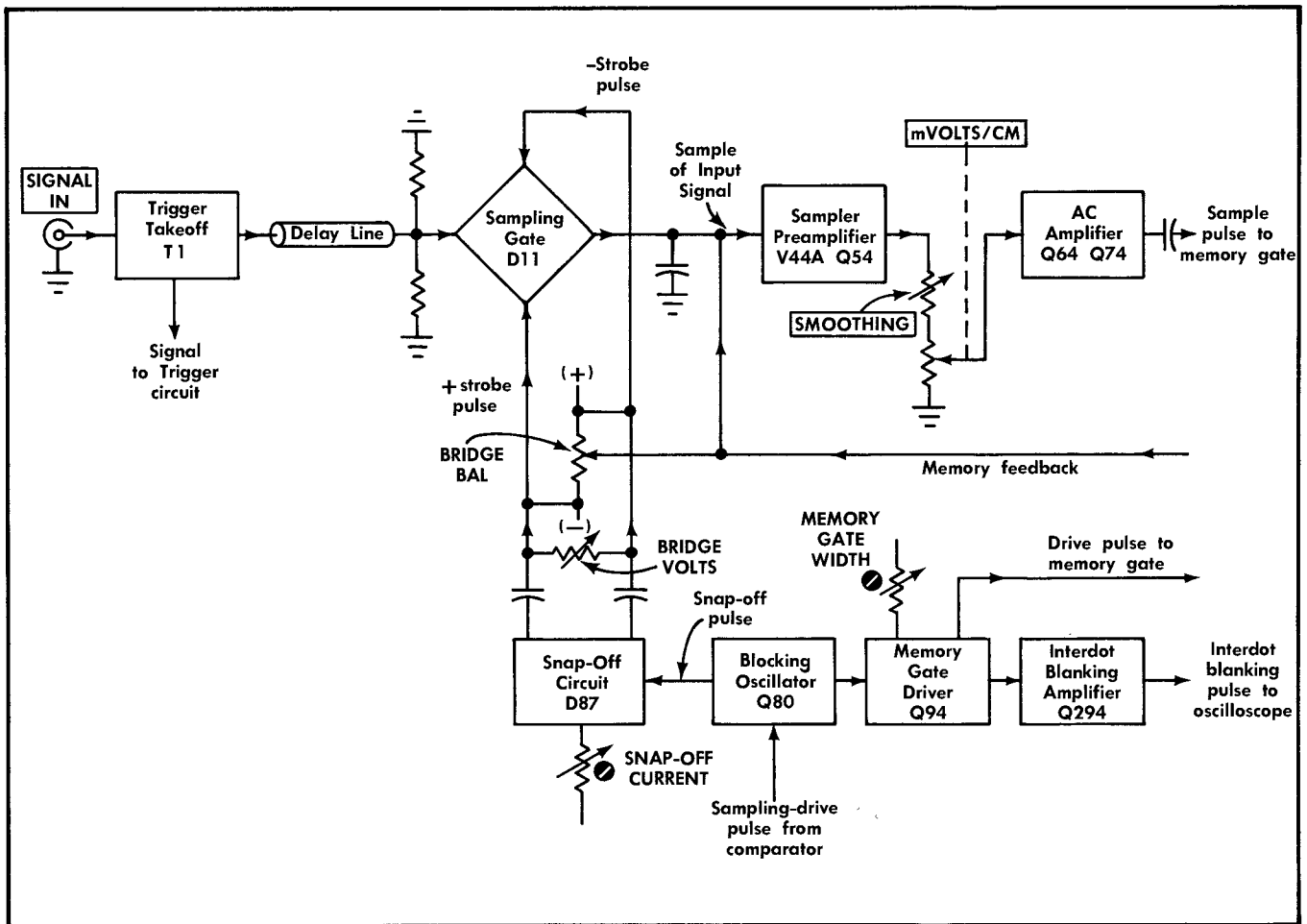

Fig. 3-4. Block diagram of the Sampler circuit.

### Delay Line

In order to display the signal that was used for triggering, the input signal must be delayed by at least 40 nsec to allow the triggering and sweep circuitry to respond to the triggering information. This signal delay is provided by passing the vertical input signal through a special delay cable between the trigger takeoff and the sampling gate. The horizontal system can then start the sampling operation before the triggering portion of the vertical input signal reaches the sampling gate. This permits samples to be taken prior to the leading edge of a fast-rise pulse.

High-frequency attenuation produced by the delay line is compensated by R4-C4, R5-C5 and L10-L11 at the input to the sampling gate. The input is terminated in 50 ohms primarily by R7 and R8 in parallel. At dc, R1 reduces the input resistance to about 49 ohms, but at higher frequencies the inductance of R1 makes it effectively an open circuit and the input impedance is determined only by the 50-ohm delay line and termination.

### Sampling Gate

Diodes D11A-D which make up the sampling gate bridge are special gallium arsenide diodes with very fast switching characteristics. Between sampling events, the sampling gate bridge diodes are reverse biased by a little more than 2

volts, preventing passage of the input signal which is always connected through the delay line to the input of the bridge. Reverse bias on the diodes is set by the BRIDGE VOLTS adjustment, R22. Balance of the bridge voltage is adjusted by the BRIDGE BAL adjustment, R30, so that no error-correction signals are produced when there is no signal change at the input.

When a push-pull sampling-drive signal is received from the snap-off circuit, approximately 2 volts of forward bias is applied across each of the 4 diodes, allowing the vertical input signal to pass through the diodes momentarily. The time constant at the output of the sampling gate, resulting from the input impedance and the circuit capacitance, is considerably longer than the 340-psec duration of the sampling-drive pulse from the snap-off circuit. This limits the initial amplitude of the sampled signal to about 30% of the difference between the previous sample level and the signal level at the time the new sample was taken. The remaining 70% of the change required at the input to the sampler preamplifier must be made up by positive feedback from the memory output so the sampling gate will be at the proper level for taking the next sample. Because only about 30% of the difference signal is able to pass through the sampling gate, the Type 1S1 is said to have a sampling efficiency of 30%.

### Sampler Preamplifier

The sampled pulse from the sampling gate is sent through R36 to the grid of V44A which amplifies the signal and applies it to the base of Q54. The signal is again amplified by Q54 and sent through C56 and the SMOOTHING control to the error-correction attenuator.

The feedback loop from the collector of Q54 to the cathode of V44A sets the output amplitude of the sampler preamplifier and also bootstraps V44A to keep the grid impedance relatively high. Gain of the circuit is approximately 13, set primarily by R52 and R39. The duration of the output pulse is stretched to about 400 nsec by the capacitance at the grid of V44A and by the time constant of R52-L52.

### Error-Correction Attenuator

The amount of attenuation produced by the error-correction attenuator, R58-R60, is selected by the mVOLTS/CM switch (SW60) to maintain a gain of one in the sampling feedback loop while the memory output amplitude is changed with the feedback attenuator.

The SMOOTHING control (R56) is part of the voltage divider at the input of the error-correction attenuator; thus, the SMOOTHING control can adjust the error signal amplitude across the divider to change the gain of the sampling feedback loop. This does not affect the vertical gain of the display, since it is within the sampling loop, but does change the ability of the sampling loop to follow the changes of the input signal. The loop is set for correct response (unity loop gain) when the SMOOTHING control is set to NORM (clockwise) position. When the control is then turned counterclockwise, the loop gain is decreased and the feedback voltage to the sampler preamplifier input cannot provide full correction for the 30% sampling efficiency. Decreasing the loop gain permits a reduction of system noise amplification when high input sensitivities are used but also may reduce the apparent transient response of the system if the display dot density is too low.

### AC Amplifier

The ac amplifier is made up of an amplifier and an output emitter follower with dc-coupled negative feedback. The error-correction pulse from the attenuator is applied through R62 to the base of Q64. The amplified and inverted signal at the collector of Q64 is then connected through emitter follower Q74 to the output of the circuit. Amplification of the stage is about 30. The error-correction signal is then applied to C76 at the memory gate input to be used for charging the memory capacitor.

### Memory Gate Driver

Diodes D90 and D92 at the input to the memory gate driver are forward biased and conducting between sampling pulses. Current division between the diodes is adjusted by R95, the MEMORY GATE WIDTH control, which also sets the voltage at the base of Q94 slightly positive and holds the transistor in cutoff. A voltage of approximately -19 volts on the collector of Q94, received through the memory gate circuit, sets the transistor so that it will saturate easily.

As D90 is momentarily reverse biased by the negative-going pulse from the blocking oscillator, current which had been passing through D90 is switched to D92. This causes Q94 to saturate quickly, producing the positive-going memory gate driver pulse at the collector of Q94. This positive-going gate pulse is sent to T110 in the memory gate circuit to turn on the gate, and to the base of the interdot blanking amplifier, Q294.

When the differentiated pulse from the blocking oscillator ends, D90 becomes forward biased again, decreasing current through D92. As soon as the charge in the base-to-emitter circuit of Q94 has been depleted, the transistor turns off, ending the memory gate driver pulse. The width of the pulse is adjusted for best performance of the sampling loop by the MEMORY GATE WIDTH control which determines the amount of charge stored in Q94 during the time that D90 is reverse biased. When R95 is set correctly, the duration of the memory gate pulse is about 350 nsec.

### Interdot Blanking Amplifier

The base of Q294 is quiescently set at -19 volts by the voltage received through T110 in the memory gate, keeping Q294 turned off. The positive-going pulse applied to the base turns on the transistor, sending a negative-going output pulse through R297 and terminal 8 of the interconnecting plug to the chopped blanking circuit in the oscilloscope. Though Q294 is turned on only for the duration of the memory gate driver pulse (approximately 350 nsec), the time duration of the interdot blanking is extended to at least 1.5  $\mu$ sec by the RC time constant in the oscilloscope chopped blanking circuit.

## MEMORY

On the memory schematic diagram are shown the memory gate, the memory, the feedback attenuator, the dc offset emitter follower and the vertical output and positioning cathode followers. Fig. 3-5 is a detailed block diagram of the memory.

### Memory Gate

The memory gate consists of diodes D110 and D112 which are pulsed into conduction by the memory gate driver through T110. The purpose of the gate is to allow the sampled error-correction signal to pass through to the memory circuit, but prevent the feedback signal that is regenerated through the amplifiers from being applied to the memory as a new error-correction signal. The memory gate is non-conducting by the time the signal is returned through the loop.

The gate diodes are normally reverse biased, with about 3 volts reverse bias set by zener diode D101. When a pulse is received from the memory gate driver, a voltage is developed across each winding of T110, forward biasing the gate diodes. The signal then passes from C76 at the output of the ac amplifier to the input of the memory circuit.

The dc level at the memory gate input is set by the MEMORY BAL adjustment, R110, so that with no error-correction signal present at the input, there will be no change in the memory output level. Capacitor C101 assures that both sides of the zener diode follow the signal equally well.

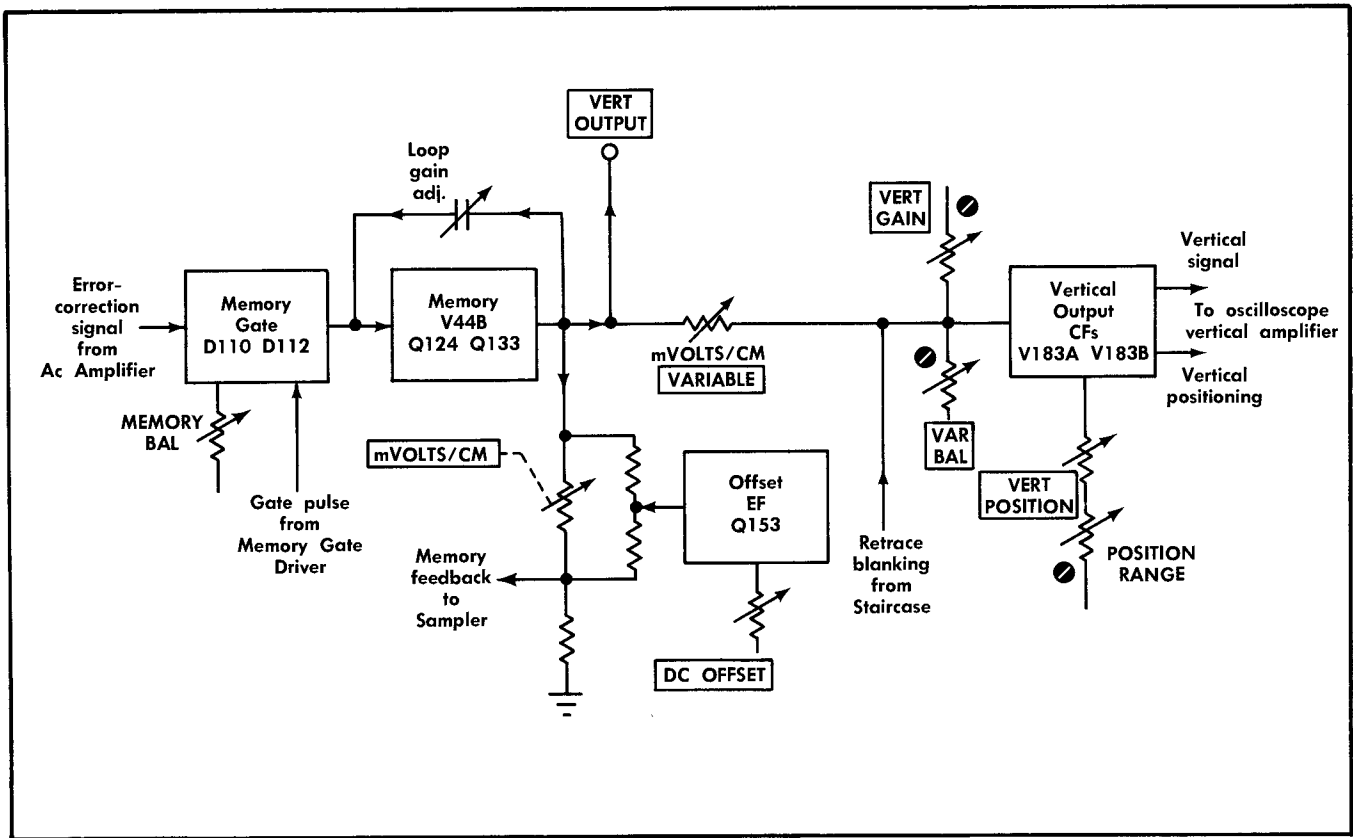

Fig. 3-5. Block diagram of the Memory circuit.

## Memory Circuit

The memory circuit is an operational amplifier using capacitors for both the input and feedback elements. The input capacitor is C76 at the output of the ac amplifier, and the feedback capacitor is the parallel combination of C135 and C136.

The error-correction signal from the ac amplifier is applied through the memory gate to the grid of V44B. The feedback action of the memory circuit places a charge on C135 and C136 equal to that applied to the input capacitor (C76). The memory gate then disconnects before the pulse from the ac amplifier has ended and the charge is left on C135 and C136.

Capacitor C135 adjusts the gain of the memory circuit to approximately 2.6, set by the ratio of C135 and C136 to C76, which adjusts the sampling loop gain to 1. A high-gain capability is needed to keep the voltage excursions at the grid of V44B very small compared to the memory output. (Open loop gain of the circuit is about 1500.) Any tendency for the grid level to change, as a result of input signal change, is amplified and returned as negative feedback through C135 and C136 to hold the grid level nearly stationary.

Between samples, the input capacitor is discharged and the ac amplifier output returns to a quiescent level. When the next sampled pulse is received, if there is a change at the input, the memory capacitor will receive a new signal

and will add or subtract the new signal from the residual charge, depending on whether the new level is above or below the previous one. Since grid current in V44B is very low and total leakage from the memory capacitor is very small, there is essentially no change in the memory output level between samples if there is no change at the input. Memory drift (dot slash) that may occur at a sampling rate below approximately 50 samples/sec is caused by a small amount of leakage current.

## DC Offset

The dc offset circuit consists of emitter follower Q153 which introduces dc shift into the sampling feedback loop. This transistor serves as a low-impedance source connected to the feedback loop between R145K and R145L. Front-panel DC OFFSET control R159 causes a  $-17$ -volt to  $+17$ -volt swing at the base of Q153 as the control is rotated from one end to the other. The emitter swing, following the base, causes a swing of  $\pm 1$  volt in the feedback loop and a voltage swing of  $\pm 10$  volts at the OFFSET OUTPUT jack. Current through the feedback attenuator remains constant, regardless of the dc voltage level inserted by Q153.

## Feedback Loop

Feedback from the memory output to the sampling gate bridge makes up for the 30% efficiency of the sampling gate. Since the memory output level determines the level of each

## Circuit Description—Type 1S1

displayed sample, the amount of attenuation the feedback loop determines the gain of the display by setting the ratio between the voltage level at the memory output and that at the sampling gate. For correct response, the feedback following each sample must be of the amplitude required to bring the level at the sampling gate up to the level of the input signal during the previous sampling instant. When it is adjusted, the loop is said to have a gain of 1.

As the feedback signal is decreased to increase the display gain, amplification of the error-correction sample must also be increased to keep the loop gain at 1. Since the gain of the amplifiers is fixed, the additional amplification is produced by allowing more of the error-correction signal to pass through R58-R60 to the ac amplifier. The error-correction attenuation caused by R58-R60, therefore, must decrease as the feedback attenuation is increased. These two attenuators are operated simultaneously by the front-panel mVOLTS/CM switch, SW60.

## Output Cathode Followers

The 600 mv/cm output from the memory circuit is applied through two divider networks to the grid of cathode-follower V183A. This divider action reduces the 600 mv/cm to the 100 mv/cm required by the oscilloscope vertical amplifier. The mVolts/Cm VARIABLE control (R165) is one of the resistors making up the attenuators. Due to its voltage division with R167 and R168, the VARIABLE control can increase the display amplitude by a factor of 4. Since this control occurs in the circuit following the VERT OUTPUT jack and the feedback loop, it does not affect the output voltage at either the VERT OUTPUT jack or the OFFSET OUTPUT jack.

During retrace of the staircase, a blanking pulse is applied from the retrace blanking amplifier in the staircase circuit through D175 and R177 to the grid of V183A. This negative-going gate pulse moves the trace off screen (in a negative direction) while the crt beam is returning to the left edge of the screen. During the staircase, D175 is reverse biased, disconnecting the blanking amplifier from the vertical system.

Vertical positioning cathode-follower V183B provides positioning of the display by changing the dc voltage applied through pin 3 of the interconnecting plug to one side of the vertical amplifier in the oscilloscope. The output voltage from V183B is adjusted by the front-panel VERT POSITION control and by the internal POSITION RANGE adjustment (R194). The positioning range produced by the VERT POSITION control is 10 cm or more on the crt screen.

## HORIZONTAL SYSTEM

The horizontal system of the Type 1S1 provides the horizontal deflection voltage for the display oscilloscope and simultaneously controls the time at which the vertical system samples the input signal. The horizontal system utilizes a tunnel-diode trigger circuit possessing wide bandwidth capabilities, a Miller-type staircase generator for generating the equivalent-time sweep, and a fast ramp circuit that develops the real-time time base for operating the sampling system. Triggering up to 1 Gc is provided by the tunnel diode trigger circuit.

## Cycle of Operation

The input triggering signal that starts the operation of the unit is received either from the trigger takeoff in the vertical system or from the front-panel EXT TRIG connector. The trigger circuit input recognizes either positive-going or negative-going triggering signals, depending on the setting of the TRIGGER SOURCE switch. After recognizing an excursion of the input signal, the trigger circuit produces an output pulse that unclamps the fast ramp generator and permits it to start the fast rundown. The trigger holdoff multivibrator then prevents another trigger recognition from being made until after the fast ramp has run down and been reset.

The fast ramp voltage is applied to the comparator circuit where it is compared to the staircase feedback voltage received through the staircase inverted circuit. When the fast ramp voltage becomes equal to the existing level of the staircase feedback, the comparator produces an output pulse which is sent to the vertical system as a sampling-drive pulse, and to the staircase generator as unlock and advance pulses. Since the voltage ramp is linear, the dc level of the ramp at the time of comparison is proportional to the amount of time that it takes the ramp to run down to the staircase feedback level. Thus, the horizontal position of each dot on the crt screen is proportional to the real time duration between triggering and the taking of a sample. The staircase-advance pulse, applied through the staircase driver, pulses the staircase circuit, causing the output level to advance one step.

One trigger recognition must be made for each dot to be displayed. Each time the trigger circuit makes a recognition, the fast ramp makes a rundown excursion, the comparator produces an output pulse and the staircase generator steps up another increment. The resulting staircase output is applied by way of the front-panel HORIZ OUTPUT jack to the oscilloscope horizontal amplifier to produce the equivalent-time sweep and also is fed back to the staircase inverter circuit to provide the comparison voltage that determines the time a sample is taken and displayed. The size of the staircase voltage increments, set by the SAMPLES/CM control, determines the equivalent-time spacing between samples (dot density). For example, if the size of the steps between samples is set so that there are 1000 samples per sweep, the fast ramp will run down 1000 times while the staircase output moves the crt spot across the screen one time.

When the staircase output reaches a certain value (set by the SWEEP LENGTH control), it resets the sweep-gating multivibrator, causing the Miller capacitor to discharge and the retrace blanking amplifier to deflect the crt beam off screen during retrace of the beam. The sweep-gating multivibrator is then ready to permit a new staircase to start when the next sweep-unlock and staircase-advance pulses are received.

When the DISPLAY MODE switch is set to either the EXT HORIZ or MAN position, the staircase voltage is not used. Instead, an externally-derived deflection voltage or an internal dc voltage is applied through the staircase generator and the HORIZ OUTPUT jack to the oscilloscope horizontal amplifier. The display timing is the same as when the staircase sweep is used, but the scanning rate is set by the external signal or the dc level change. In either case, the

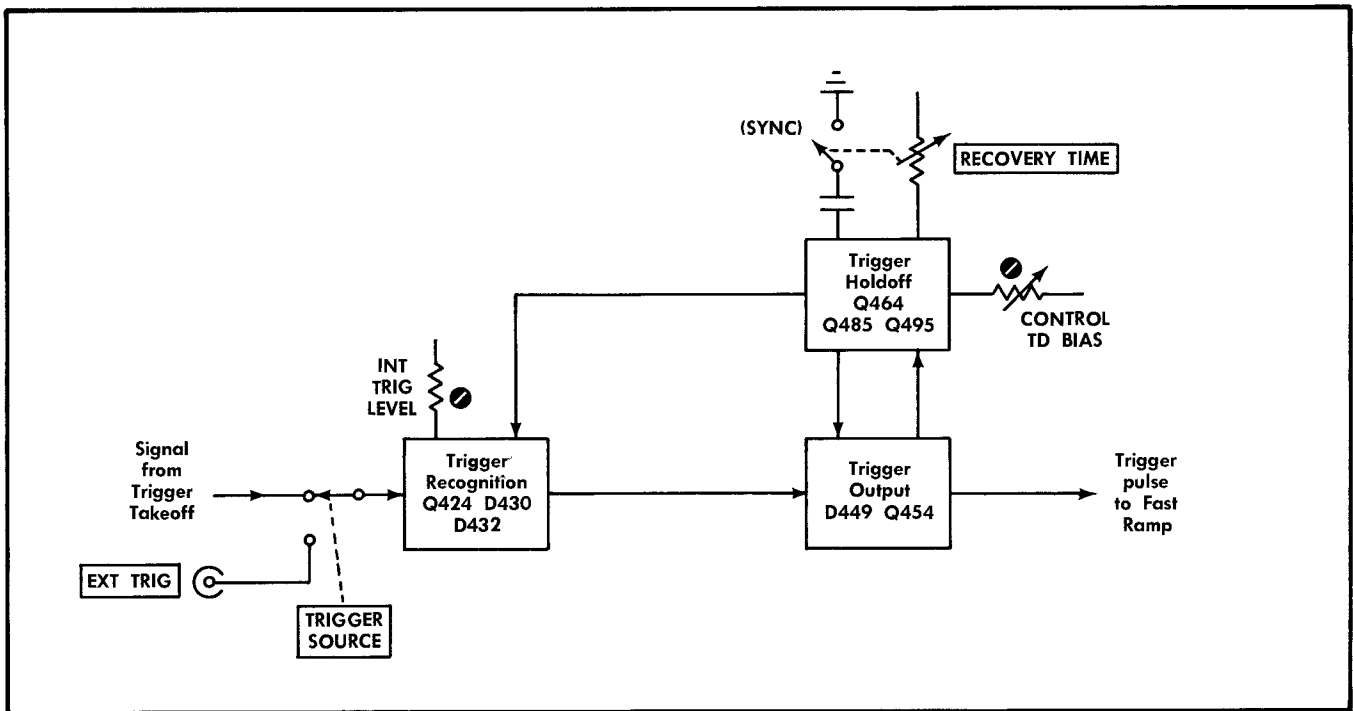

Fig. 3-6. Block diagram of the Trigger circuit.

feedback from the staircase generator to the staircase inverter still determines the horizontal position of the crt beam at the time of comparison, and the fast ramp still determines the equivalent time/cm of the display. Thus, the crt display always represents equivalent time, regardless of the source of scanning voltage.

The TIME POSITION and FINE controls can adjust the time at which the comparison pulse causes the vertical system to take a sample by raising or lowering the dc level of the staircase feedback signal to which the fast ramp must run. The effect of these controls is to shift the "time window" of the observed crt display.

## TRIGGER CIRCUIT

The schematic diagram of the trigger circuit shows the input switching to the circuit, the trigger recognition circuit, the trigger output circuit and the trigger holdoff. Fig. 3-6 is a block diagram of the trigger circuit.

### Trigger Source Switch

The TRIGGER SOURCE switch (SW400) is used to select the triggering signal either from the trigger takeoff at the vertical input or from the EXT TRIG input connector. The signal voltage received from the trigger takeoff is approximately 1/7th the amplitude of the vertical input amplitude. The trigger input that is not used is terminated in 50 ohms by R401 and R402 or by R405 and R406. In addition to selecting the source, the TRIGGER SOURCE switch also selects the polarity of the input signal that will cause a trigger recognition, by sending the signal either directly to the trigger circuit (with the switch at one of the + positions)

or by connecting the signal through inverting transformer T410 (with the switch at one of the — positions). A low-frequency termination and a high-frequency ground for the primary of T410 are provided by R412, R413, C412 and C413. The values of these components match the frequency response characteristics of the transformer.

Both triggering sources are disconnected from the trigger circuit input when the TRIGGER SOURCE switch is set to FREE RUN position. The FREE RUN position of the switch also changes the operation of the trigger circuit so the display will free run regardless of the triggering controls.

### Trigger Recognition and Output

The trigger circuit operates in a triggered mode on input triggering signals from 10 cps up to 1 Gc or more. Below approximately 100 kc, pulse triggering is required because of the sinewave rolloff produced by the capacitive input coupling through C415. Above the maximum repetition rate of the holdoff circuit, countdown occurs and trigger recognition takes place on the first input signal excursion of the correct slope following the holdoff period. On triggering signals above about 10 Mc, the circuit attempts to synchronize with the input signal during the small interval of time between the end of the holdoff period and the time that the circuit is ready to be triggered.

Input transistor Q424, connected in a common-base configuration, provides isolation between the trigger input and recognition diode D430 to minimize trigger kickout when the tunnel diode switches. Part of the bias current for D430 is provided through Q424 and the INT TRIG LEVEL adjustment, R420. The remainder of the bias is supplied from current-switch transistor Q464, which also provides bias for

## Circuit Description—Type 1S1

control tunnel diode D449. The front-panel TRIGGER SENSITIVITY control sets the sensitivity of the trigger recognition circuit by adjusting the current division between D430 and R435 (TRIGGER SENSITIVITY). The INT TRIG LEVEL adjustment, R420, sets the dc current through Q424 to adjust the operating range of the TRIGGER SENSITIVITY control.

When the trigger circuit is set for triggered operation, the quiescent circuit conditions following reset and before the arrival of another triggering excursion are as follows: Q424 is conducting moderately; Q454 is cut off and Q464 is held in saturation by the trigger holdoff circuit; D430 and D449 are biased in the low-voltage state near the switching point; D456 is reverse biased and D470 is forward biased. Back diode D432, which is part of the high-frequency synchronizing circuit, is non-conducting.

**Normal Triggered Operation.** A positive-going signal at the emitter of Q424 (corresponding to a positive-going input signal excursion when the TRIGGER SOURCE switch is set to one of the + positions) causes current to increase through Q424 and thus through D430. When the triggering signal excursion raises the diode to its switching level, D430 sends an output pulse through C448, R449 and L449 to control tunnel diode D449.

Since D449 is set near its switching point by current through R460 (CONTROL TD BIAS), the positive-going pulse from D430 causes D449 to switch to its high-voltage state. The resulting positive-going pulse is applied through L302 to the fast ramp circuit and through L449, R449 and R448 to the base of Q454, turning on that transistor. As Q454 turns on, the negative-going voltage at its collector reverse biases D470 to start the operation of the trigger holdoff circuit. As soon as recognition tunnel diode D430 has switched to its high-voltage state and has pulsed D449, D430 is immediately reset to its low-voltage state by back diode D432. The rate at which D430 is reset is determined by the L/R time constant of L428, D432 and D430. Then, as Q454 becomes saturated, D456 turns on and diverts enough current to keep D430 in its low-voltage state, preventing another trigger recognition from being made. However, current remains sufficient to hold D449 in its high-voltage state.

At the half-way point of the trigger holdoff interval, Q464 is turned off by the trigger holdoff circuit. With the current source removed, D449 resets to its low-voltage state and Q454 turns off, but D430 is still not triggerable. At the end of the holdoff period when Q454 is turned on again, current is restored through Q464 and the trigger recognition circuit becomes rearmed and able to be triggered by the input signal.

**Synchronized Operation.** When the RECOVERY TIME control is switched to the SYNC position, the rearming rate of control tunnel diode D449, following holdoff, is retarded by connecting C461 to ground. During the time that D449 is recovering, D430, L428 and D432 operate as a free-running multivibrator. Diode D432 sets the load on D430 so that it will turn on and stay on momentarily, then turn off and stay off momentarily, and repeat the cycle until D449 has reached the triggerable level. If a triggering signal between 20 Mc and 1 Gc is applied to the input of the circuit, the frequency of the free-running multivibrator can be adjusted with the TRIGGER SENSITIVITY control to synchronize with the signal. Each time D430 switches to its high state, a small pulse is applied to D449; however, D449 cannot be triggered until it has reached the proper bias level. As

the bias on D449 reaches the triggerable level, the first of the small triggers from D430 that is able to raise D449 above its switching point causes D449 to switch and produce a normal output pulse to the fast ramp. The normal holdoff interval follows, then another triggering cycle begins as D430 and D432 again synchronize on the input triggering signal. In this way, D449 becomes synchronized (at a much lower frequency) to the input signal.

**Free Run.** When the TRIGGER SOURCE switch is set to FREE RUN position, R460 (CONTROL TD BIAS) is shorted out, providing enough bias current for D449 so it will switch to its high-voltage state following the holdoff interval without waiting for the recognition tunnel diode to produce a pulse.

Free run operation also occurs when the TRIGGER SOURCE switch is set to one of the INT or EXT positions and the TRIGGER SENSITIVITY control is turned toward the clockwise end of its range of rotation. In this case, however, the bias level on D430, rather than the bias on D449, is set to the free run level. Following the holdoff interval, D430 automatically switches to its high-voltage state, triggering control tunnel diode D449 to produce an output pulse. In this method of free run, the trigger circuit may also synchronize with input triggering signals above 20 Mc, just as with the RECOVERY TIME control at SYNC position. Since the rearming of D449 is faster with the RECOVERY TIME control switched out of SYNC position, this synchronization may not be quite as stable (at some frequencies) as it is with the control set to SYNC position.

## Trigger Holdoff

Before the arrival of an input triggering event, transistors Q485 and Q495, making up the trigger holdoff multivibrator, are in a saturated condition. Diodes D472, D482 and D490 are reverse biased, and diodes D470 and D492 are forward biased. Trigger holdoff capacitors C479 and C480 are charged to a value established by their total capacitance, as selected by the TIME POSITION RANGE switch, and by the voltage at the junction of R478 and R480 (approximately +12 volts). Current through R495 and Q495 keeps transistor Q464 in saturation to provide bias for the trigger tunnel diodes.

When D470 is reverse biased as Q454 turns on, current flow switches from D470 to D472, initiating the rundown portion of the holdoff cycle. The trigger holdoff capacitors begin to discharge toward the -139-volt supply through D472, R470, R473 and R475 (RECOVERY TIME). The rate of discharge is determined primarily by the holdoff capacitors and can be adjusted over about a 30% range by the RECOVERY TIME control. Minimum recovery time is obtained with the control set fully counterclockwise, but not switched to SYNC position.

When the voltage at the junction of R470 and R473 reaches approximately ground level, D490 becomes forward biased, diverting current from the base circuit of Q495. This turns off Q495, which turns off Q464 and Q485, forward biasing D482. With Q464 turned off, control tunnel diode D449 resets, turning off Q454 and forward biasing D470. This is the halfway point of the holdoff cycle.

As D470 turns on, current is again diverted from D472 and both D472 and D490 become reverse biased. Transistor Q495 does not turn on at this time, however, since its cur-

rent path through Q485 is open. With D472 reverse biased and D482 conducting, the holdoff capacitors begins the runup portion of the holdoff cycle, charging toward the +100-volt supply through D482, R483 and R499. As soon as the voltage at the junction of R478 and R480 reaches about +12 volts, D482 becomes reverse biased and the runup stops. Current is then restored through the emitter-base junction of Q485, turning on that transistor. Current through the base-emitter junction of Q495 then turns on Q495 and both transistors go into saturation. As current through Q495 begins again, Q464 is turned on again and saturates, restoring the arming current to the trigger tunnel diodes. The circuit is then ready for another triggering event.

Minimum duration of the holdoff cycle is approximately 12  $\mu$ sec on the 50 nsec and 500 nsec time position ranges with only C479 connected to the circuit. For slower sweep rates larger holdoff capacitors (C326 A-D) are connected through the TIME POSITION RANGE switch to retard the holdoff rundown and runup. The holdoff interval is always slightly longer than the maximum excursion of the fast ramp.

### FAST RAMP

The fast ramp circuit consists of the staircase inverter, the fast ramp clamp and generator, and the comparator and comparison-pulse generator. Fig. 3-7 is a detailed block diagram of the fast ramp circuit.

#### Staircase Inverter

Feedback voltage from the output of the staircase gen-

erator is connected to the staircase inverter to be used as a comparison voltage for controlling the amount of sampling delay with respect to the triggering event. Transistors Q374 and Q384 are connected as an operational amplifier, with the gain determined by the ratio of feedback resistor R377 to the input resistor selected by the TIME/CM switch. When the TIME/CM switch is locked to the TIME POSITION RANGE switch, a 1-2.5-5 magnification sequence occurs for each time position range as the switches are turned clockwise. This is accomplished by selecting R530A, R530B or R530C (shown on the Timing Switch diagram) as the input resistor for the amplifier. When the switch is turned so that another position of the TIME POSITION RANGE switch is used, the amplifier repeats the 1-2.5-5 sequence, but the slope of the fast ramp has been changed to produce another sequence of equivalent-time sweep rates. When the Time/Cm MAGNIFIER knob is pulled out and turned clockwise, one of two attenuators may also be connected to the inverter input to reduce the signal amplitude and change the equivalent time/cm. The smaller the amplification factor of the amplifier ( $R_f/R_i$ ) or the greater the attenuation of the input signal, the smaller will be the output excursion of the amplifier and the shorter the equivalent time between samples. This produces the effect of magnifying the display or increasing the sweep rate, but does not change the display dot density. The Time/Cm VARIABLE control (R500) can also change the gain of the amplifier, since it is a series input resistor.

The two time-magnification attenuators are R510 A-C (a 10 $\times$  attenuator) and R520 A-C (a 100 $\times$  attenuator). The six steps of time magnification (produced by turning the

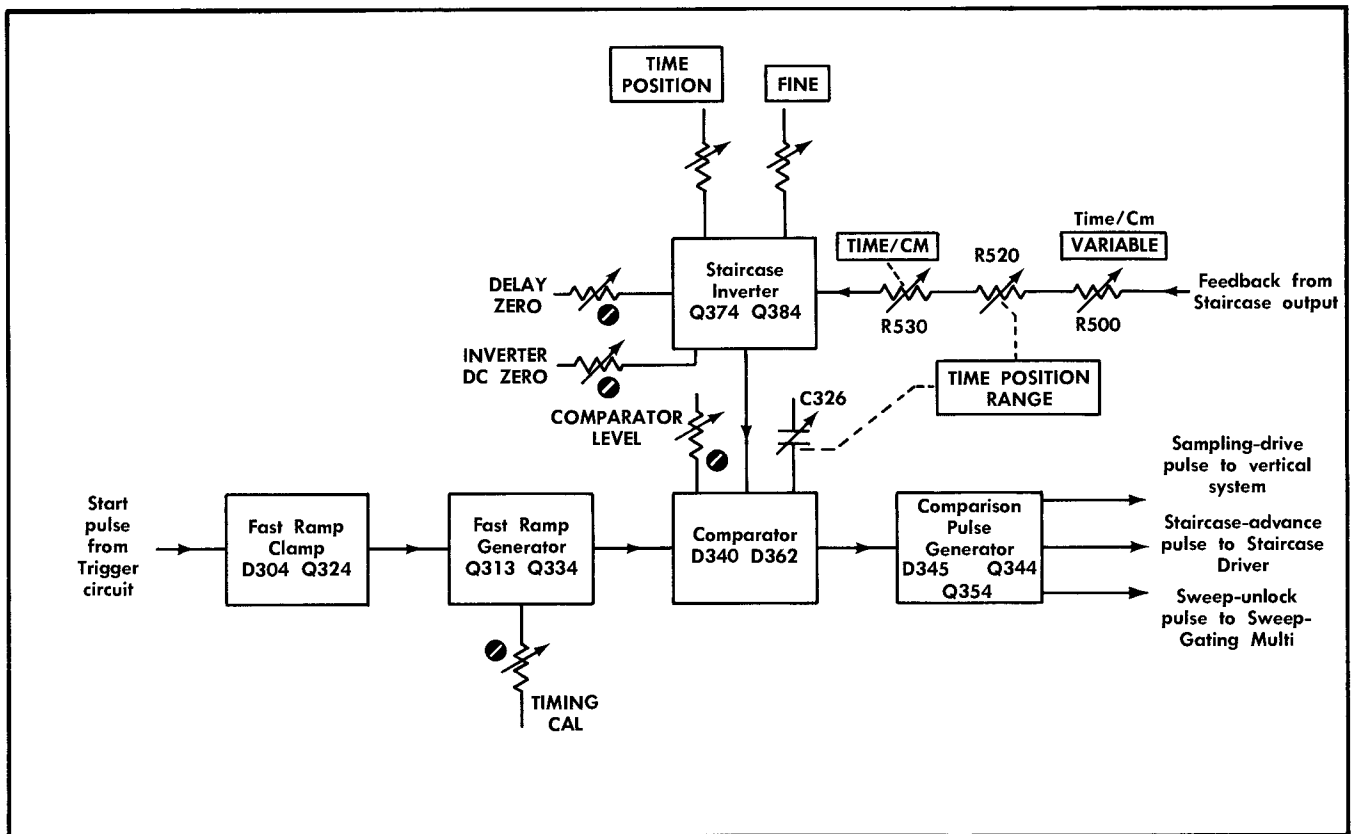

Fig. 3-7. Block diagram of the Fast Ramp circuit.

## Circuit Description—Type 151

MAGNIFIER knob clockwise) depend on the starting position of the switch and are determined by the particular combination of attenuator and series resistor used. From the "1" position, the step sequence is 2-5-10; from the "2" position, the sequence is 2-4-10; and from the "5" position, the sequence is 2.5-5-10.

The TIME POSITION and FINE controls (R365A and B) determine the dc level at which the output staircase waveform starts. The range of these controls can cause the starting level to move a total of 7.5 volts. By moving the entire staircase waveform up or down, all of the samples can be delayed or advanced by the same amount of time, having the effect of moving the "time window" of the crt screen along the waveform.

The INVERTER DC ZERO adjustment (R380) adjusts the input level of the amplifier to match the output level of the staircase start, so that no current will flow in the input resistors until the staircase begins its excursion. The DELAY ZERO adjustment (R370) is set so that the display of the delayed vertical input signal begins approximately 4 nsec before the triggering point of the waveform (on the 500 nS ramp).

When the DISPLAY MODE switch is set to the EXT HORIZ or MAN position, an external signal or dc voltage is applied through the staircase generator and the TIME/CM switch to the staircase inverter to produce the comparison voltage. Since the input current is still proportional to the horizontal deflection voltage, the horizontal position of each dot on the crt screen is still referenced to equivalent time.

### Fast Ramp Clamp and Generator

Before arrival of a pulse from the trigger circuit, Q324 is operating as a non-saturated clamp transistor with its base at about  $-0.4$  volt and its collector at about  $-2$  volts. Transistor Q334, a common-base amplifier, is supplying current to both tunnel diode D304 and the base of Q324. This current holds the tunnel diode in its high state and keeps Q324 conducting moderately but not in saturation. Current for Q324 is received through both clamp diode D315 and constant-current transistor Q334.

When the positive-going trigger pulse is received through C302, the tunnel diode switches to its low state, quickly turning off Q324 and clamp diode D315. The current that has been passing through Q334 and Q324 (approximately 7.5 ma) is then diverted into the fast ramp timing capacitors through R320 in parallel with D340 and R338. The fast ramp capacitors (shown on the Timing Switch diagram) then begin charging at a linear rate, limited at  $-19$  volts. The particular rate of the ramp rundown is determined by the capacitor selected by the TIME POSITION RANGE switch. Charging current is adjusted for correct timing by R335 (TIMING CAL) in the emitter circuit of Q334. On the fastest sweep rates, the ramp slope is 7.5 volts in 50 nsec, produced by C325 and the capacitance of the circuit. The ramp voltage continues its rundown until a comparison is made with the staircase inverter output level.

When the control tunnel diode in the trigger circuit returns to its low-voltage state halfway through the holdoff period, the negative-going pulse applied through C302 switches D304 to its high state, causing Q324 to turn on

and D315 to conduct again. The timing capacitors quickly discharge, making the circuit ready for its next rundown.

### Comparator and Comparison-Pulse Generator

The comparator circuit consists of gallium arsenide diode D362, which makes the comparison between the fast ramp and staircase inverter output, and tunnel diode D340, which produces an output pulse when the comparison is made. The pulse is then regenerated by tunnel diode D345 and amplified by Q344.

Bias current for D340 is determined by the current division between R320 and R338 (in series with D340). The COMPARATOR LEVEL adjustment (R320) is set so that D340 is biased near its switching level just prior to the time that the fast ramp and inverter voltages are equal. When D362 becomes forward biased as the fast ramp rundown voltage becomes equal to the feedback staircase voltage, the additional current through D340 switches it to its high-voltage state. The resulting negative-going pulse at the cathode of D340 is coupled through T340 and applied to the cathode of D345. Tunnel diode D345, which is connected in a monostable circuit configuration, is switched to its high-voltage state momentarily, causing Q344 to saturate. The large positive-going pulse at the collector of Q344 is applied to the blocking oscillator in the vertical system to start a cycle of the sampling process and to the staircase driver circuit to step the staircase one increment. The current pulse through R356 and the base-emitter junction of Q354 turns on that transistor, saturating it, to produce a negative pulse for unlocking the sweep-gating multivibrator.

As the pulse through T340 ends, D345 automatically reverts to its low-voltage state, attempting to turn off Q344. As soon as the stored charge in Q344 has been depleted, the transistor turns off and the output pulse ends.

## STAIRCASE

The staircase circuit schematic includes the staircase driver, the sweep-gating multivibrator, the Miller staircase generator and the retrace blanking amplifier. Fig. 3-8 is a detailed block diagram of the staircase circuit.

### Staircase Driver

Each time a comparison pulse is sent to the vertical system to initiate the taking of a sample, staircase-advance pulse is applied to the staircase driver from the comparator. The negative-going gate pulse at the base of Q254 causes the transistor to saturate, sending a negative-going pulse through C258, D262, R262 and R264 to the grid of the Miller circuit. The collector voltage on Q254, set by the front-panel SAMPLES/CM control (R254), determines the amplitude of the pulse at the collector, and thus determines the amount of energy transferred through C258 to the staircase generator.

### Sweep-Gating Multivibrator

The sweep-gating multivibrator is a bistable circuit, consisting of Q225 and Q235, a transistor pair which operates with both transistors turned on during the sweep and both



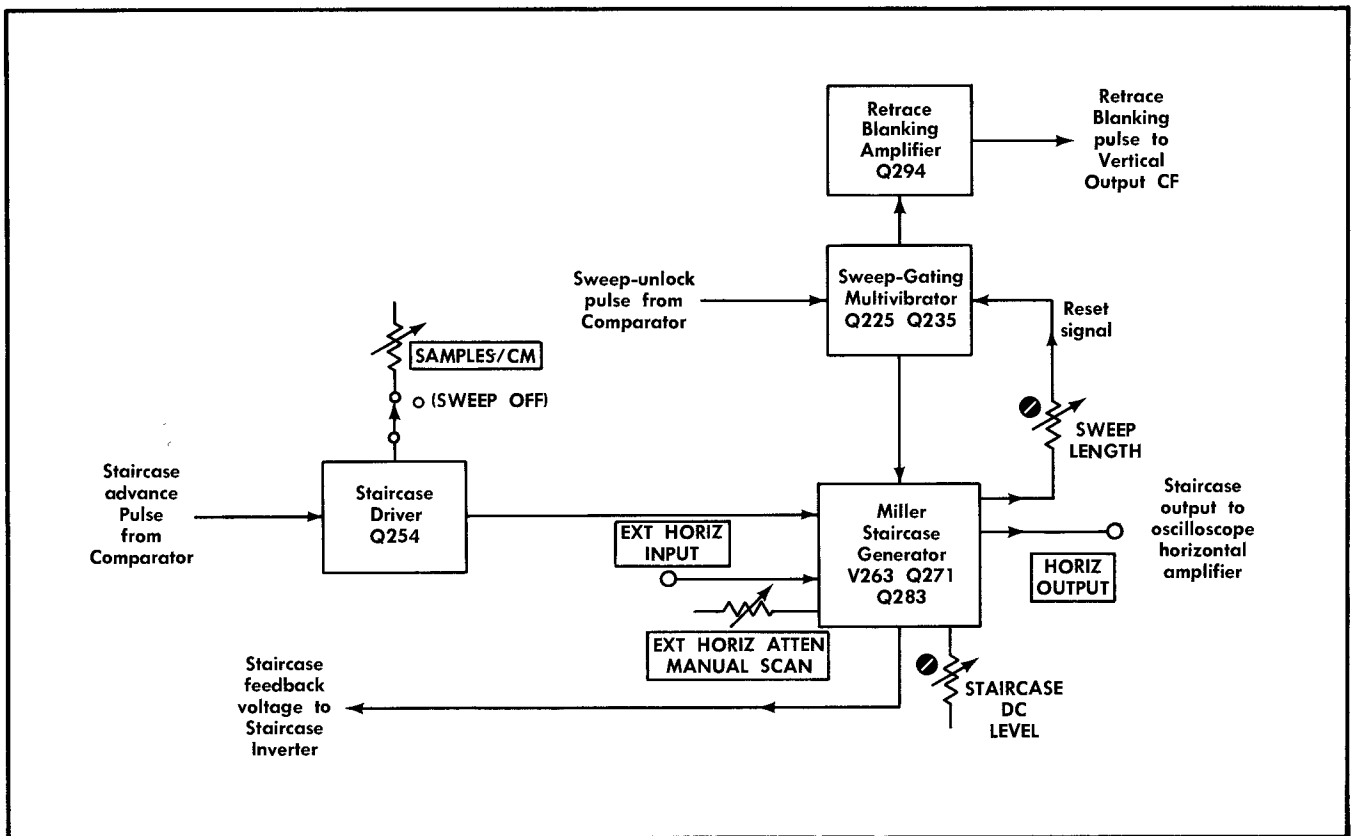

Fig. 3-8. Block diagram of the Staircase circuit.

transistors turned off during the retrace. Near the end of the retrace period, as the holdoff waveform (at the junction of C210 and R210) drops, the voltage at the base of Q225 returns toward the triggerable level of Q225, slightly above ground. With the DISPLAY MODE switch set to NORMAL, negative pulses are continuously being applied from the comparator circuit through C205 and D205. The first negative pulse that is able to forward bias the base-emitter junction of Q225 turns on the transistor, switching the multivibrator to initiate a staircase sweep. If no trigger arrives, the voltage at the base of Q225 is held at the triggerable level by current through D237 and R208.

As Q225 turns on, its collector goes positive, turning on Q235. The collector of Q235 in turn goes negative and the regenerative action of the circuit causes both transistors to saturate. The negative voltage at the collector of Q235 reverse biases D246 and D247, disconnecting the Miller circuit from its discharge path through the diodes, and the staircase capacitors are allowed to begin charging.

One of the two return paths from the staircase output to the sweep-gating multivibrator is through R290 (SWEEP LENGTH), D216 and D215. As the staircase voltage rises, more current is drawn through R215 and D216, diverting current from the base of Q225. SWEEP LENGTH adjustment R290 is set so that when the staircase voltage reaches approximately 10.2 volts, Q225 will turn off and reset the sweep-gating multivibrator. As the multivibrator resets, the positive-going voltage step at the collector of Q235 is

applied to the retrace blanking amplifier and to the disconnect diodes, D246 and D247.

Diode D246 is forward biased by the positive voltage applied to its anode, permitting the staircase capacitor to begin to discharge. The resulting rise on the grid of V263 operates through the Miller circuit, causing the staircase output voltage to drop quickly to near ground voltage. When the negative-going output forward biases D247, the diode conducts and a state of clamped equilibrium exists. Diode D246 remains forward biased, diverting current from the grid circuit of V263 until the sweep-gating multivibrator is triggered again.

A second return path from the staircase output to the sweep-gating multivibrator is through R212, D210 and R210. As the staircase capacitor begins to discharge and the staircase output voltage begins to drop, D210 becomes reverse biased, disconnecting the output from the sweep-gating multivibrator. Sweep holdoff capacitor C210, which had charged up to the staircase voltage, discharges through R210 and D237, setting the holdoff time of the staircase. As the voltage at the base of Q225 again returns to the triggerable level, Q225 becomes armed and ready to be triggered by the next negative-going pulse from the comparator to initiate a new sweep.

With the DISPLAY MODE switch set to SINGLE SWEEP, sweep-unlock pulses from the comparator are no longer connected to the sweep-gating multivibrator. Capacitor C205 is charged to +19 volts through R203 when the

## Circuit Description—Type 1S1

switch is set to SINGLE SWEEP, then when the START button is pressed, C205 is connected to ground, sending a negative-going pulse through D205 to the base of Q225. The sweep-gating multivibrator switches and permits a single sweep of the staircase to occur. At the end of the sweep, the multivibrator resets and is ready to be switched, but with the unlock pulses disconnected, subsequent sweeps are locked out until the START button is pressed again or until the DISPLAY MODE switch is set to NORMAL.

### Miller Staircase Generator

The negative-going output pulses from the staircase driver circuit are applied to the grid of V263 and to the Miller capacitor, C246. When the sweep-gating multivibrator is holding off the sweep, the energy of the stepping pulses is sent through D246 and is dissipated. As soon as the sweep-gating multivibrator has switched and disconnected D246 (the discharge path), the pulse energy starts to charge up the Miller capacitors. The voltage on the grid of V263 begins to drop and the voltage at the cathode follows. An amplified positive-going signal is produced at the collector of Q271 and connected to the output through emitter-follower Q283. This signal, coupled back to C246, keeps the grid of V263 nearly stationary, so the energy pulses from the staircase driver appear as a stepping increase of charge on C246.

The staircase output voltage which runs from zero to 10.2 volts, is sent through the TIME/CM switch (shown on the Timing Switch diagram) to the staircase inverter and is connected to the front-panel HORIZ OUTPUT jack to be applied to the oscilloscope horizontal amplifier. The output dc level is adjusted by R270 (STAIRCASE DC LEVEL) so the staircase starts at zero volts. Calibration of the Type 1S1 timing is adjusted to be correct when the horizontal deflection factor of the oscilloscope is set to produce 1 cm of deflection for each volt of staircase amplitude.

When enough pulses have been received to raise the charge on the Miller capacitor to the required staircase amplitude, the sweep-gating multivibrator is reset, causing the disconnect diodes to discharge the Miller capacitor, and the staircase recovers to produce another sweep.

When the DISPLAY MODE switch is set to EXT HORIZ or MAN position, the staircase is disabled by disconnecting the output of Q271 from the base of Q283. With the switch at EXT HORIZ, an external scanning voltage applied through the front-panel EXT HORIZ INPUT jack is sent through R293 to the attenuator made up of R292 and R280 in the base circuit of Q283. Diode D292 is turned on by current through the attenuator. The external signal is connected through R293, D292 and emitter-follower Q283 to the output of the circuit. This output is then applied to the oscilloscope horizontal amplifier and to the staircase inverter in the same manner as the normal staircase voltage. The EXT HORIZ ATTEN (MANUAL SCAN) control, R293, adjusts the input signal attenuation to produce horizontal deflection factors of from 1 volt/cm to more than 16 volts/cm of display.

With the DISPLAY MODE switch at MAN position, the operation is nearly the same as with the switch at EXT HORIZ, except that the voltage applied to Q283 is a variable dc voltage taken from divider R295-R293 and applied to attenuator R292-R280. The dc voltage can be adjusted

from zero volts to more than +10 volts with R293 (MANUAL SCAN) to scan the display manually.

In either the EXT HORIZ or MAN mode, as in NORMAL mode, the feedback voltage to the staircase inverter is proportional to the output voltage applied to the horizontal amplifier. Thus the comparison pulse is generated at a time that is directly related to the horizontal position of the dot on the crt screen, and the display remains calibrated in equivalent time.

### Retrace Blanking Amplifier

Transistor Q244 is turned on each time the sweep-gating multivibrator is reset for retrace and is turned off when the multivibrator switches to start a sweep. The negative-going gate pulse appearing at the collector of Q244 is applied through D175 to the grid circuit of the vertical output cathode follower (V183A) to deflect the crt beam off the screen during retrace.

## POWER SUPPLY

The power supply circuit provides regulated voltage sources for the -19-volt and +19-volt supplies and a low-impedance current source for the -139-volt supply. These circuits assure that the operating voltages will remain stable and that ample current will be available for the current pulses required for the sampling process.

### -19-Volt Supply

Voltage reference for the -19-volt supply is zener diode D645. Ac power received from the oscilloscope through pins 13 and 14 of the interconnecting plug provide 6.3 volts for the operation of T630. The secondary of T630 supplies power to the rectifier consisting of D630 and D632 which produces an output of approximately 30 volts across C632. The series regulator circuit consists of comparator transistor Q634, emitter follower Q653 and series transistor Q657. A precision divider, R656-R658-R657, provides a comparison voltage of approximately -14.5 volts at the base of Q634 when the -19 V CAL adjustment (R658) is set for the correct output voltage. Current through Q634, set by the base voltage, adjusts its collector voltage to provide the correct current drive through Q653 to the base of Q657.

To illustrate the regulator action, assume that the output voltage tends to go slightly positive due to an increased load on the -19-volt supply. The precision voltage divider will increase the bias on Q634, decreasing its collector current. The voltage at the base of Q653 and the base of Q657 then goes slightly negative, increasing current through Q657 and returning the voltage output (through the rectifier) to -19-volts.

Diode D638, in the emitter circuit of Q634, provides a reference voltage for the -19-volt regulator during the warm up period before the oscilloscope -150-volt supply turns on. Temperature compensation for Q634 is provided by diode D636.

### +19-Volt Supply

Current for the +19-volt supply comes primarily from the oscilloscope +75-volt supply through pin 15 of the inter-

connecting plug. This voltage is produced by dropping the +75 volts across the series resistance of R607, R606, and the filaments of V263, V183 and V44. The voltage reference for this supply is the -19-volt supply, therefore the -19-volt supply must be set correctly for the +19-volt supply to be correct.

The shunt regulator consists of comparator Q614 and shunt transistors Q624 and Q627. Transistor Q614 compares a voltage near ground (through D616) to the voltage at the center of precision divider R623-R625-R626. Temperature compensation for Q614 is provided by diode D616.

Assume that the output voltage tends to go slightly negative due to an increased load on the supply. The precision divider will then decrease the bias current to Q614, causing the voltage at the base of Q624 to become more positive. Current will therefore decrease through Q624 and Q627, allowing the supply to return to +19 volts.

### **-138-Volt and -139-Volt Supplies**

Transistor Q667 is an emitter-follower circuit providing a low-impedance voltage source for the -139-volt supply

that is able to provide the large current pulses required for sampling. The action of this regulator circuit presents a constant current load on the decoupled -150-volt supply in the oscilloscope and eliminates voltage fluctuations that would be coupled to other circuits.

The -138-volt supply is connected to fixed current loads in the Type 1S1 which draw a total of about 25 ma of current and set the operating level of zener diode D662. The constant current through D662 holds the base of Q667 approximately 6.2 volts more positive than the -144 volts received from the dc coupled -150-volt supply. Voltage at the emitter of Q667 is therefore approximately -139 volts, due to the emitter follower action.

Transistor Q667, connected in parallel with the current load on the -139-volt supply, conducts the current that is not needed by the sampling circuits. A sudden increase in current load in the instrument makes the voltage across R662 tend to increase and the voltage at the emitter of Q667 tend to go positive. The resulting current decrease through Q667 returns the voltage to -139 volts and holds the current constant through R662.



# SECTION 4

## MAINTENANCE

This section of the manual contains maintenance and troubleshooting suggestions for the Type 1S1. Illustrations are included for locating circuit components mounted on the etched-wiring boards.

### PREVENTIVE MAINTENANCE

Preventive maintenance consists of cleaning, visual inspection, lubrication and recalibration. Preventive maintenance performed on a regular basis helps prevent instrument failure and improves reliability of the instrument. The severity of the environment will determine the frequency of maintenance.

#### Cleaning

The Type 1S1 should be cleaned as often as operating conditions require. The side panels of the oscilloscope provide partial protection against dust accumulation in the interior of the instrument, but a certain amount of dust is brought in by circulating air. Operation without the side panels in place requires more frequent cleaning. If the Type 1S1 is stored on a shelf when not in use, cover it with a cloth or piece of plastic to keep dust from collecting in the instrument.

The front panel of the Type 1S1 may be cleaned with a soft cloth dampened with a mild solution of water and detergent. Abrasive cleaners should not be used.

To clean the interior, blow off any accumulated dust with a low-velocity stream of dry air. Do not use high-velocity compressed air, as this may damage some of the small components. Any dust or dirt remaining in the interior may be removed with a small cloth or cotton-tipped applicator dampened with isopropanol or a mild solution of water and detergent.

#### CAUTION

Do not clean any plastic materials with organic chemical solvents such as benzene, acetone or denatured ethyl alcohol. These may damage the plastics. (Isopropanol is safe to use.)

#### Lubrication

The reliability of potentiometers, rotary switches and other moving parts can be increased by keeping them properly lubricated. Use a cleaning-type lubricant on shaft bushings, interconnecting plug contacts and switch contacts. Lubricate switch detents with a heavier grease. A lubrication kit containing the necessary lubricating materials and instructions is available from Tektronix (Tektronix Part Number 003-0342-00).

#### Visual Inspection

The Type 1S1 should be inspected occasionally for possible defects such as damaged connectors, improperly seated

transistors or tubes, frayed cable shields and heat-damaged components.

The corrective procedures for most visible defects are obvious. Particular care must be taken, however, if heat-damaged parts are located. Overheating usually indicates other trouble in the instrument. For this reason, the cause of the overheating should be located and corrected before operating the instrument.

#### Transistor and Tube Checks

Periodic checks of the transistors and tubes used in the Type 1S1 are not recommended. The best check of performance is the actual operation of the component in the circuit. However, if a circuit malfunction occurs, the transistors and tubes in the circuit should be checked as described in the troubleshooting portion of this section of the manual.

#### Recalibration

To ensure that the Type 1S1 is operating correctly and accurately, it should be checked and recalibrated after each 500 hours of operation, and at least once every 6 months. Complete calibration instructions are given in Section 5. In some cases, minor troubles not apparent during normal use may be revealed or corrected by recalibration.

### CORRECTIVE MAINTENANCE

Corrective maintenance generally consists of component replacement and instrument repair. Special techniques or procedures required for replacing parts in the Type 1S1 are described here.

#### Replacement Parts

**Standard Parts.** All electrical and mechanical replacement parts for the Type 1S1 can be obtained through your local Tektronix Field Office or representative. However, many of the standard electronic components can be obtained in less time by purchasing them locally. Before purchasing or ordering replacements parts, consult the Parts List in Section 6 of this manual for the required characteristics.

#### NOTE

When obtaining replacement parts, remember that the physical size and shape of a component may affect its performance, especially at high frequencies. Replace components only with identical parts unless it is known that a different component will not adversely affect the instrument operation.

**Special Parts.** In addition to the standard electronic components, some special components and parts are used in the Type 1S1. These parts are manufactured by or for

## Maintenance—Type 1S1

Tektronix, or are selected by Tektronix to meet specific performance requirements. Each of these special parts is indicated in the Parts List by an asterisk preceding the part number. In addition, most of the mechanical parts used in this instrument have been manufactured by Tektronix. Order all special parts directly from your Tektronix Field Office or representative.

### Ordering Parts

When ordering replacement parts from Tektronix, always including the following information:

1. A complete description of the part as given in the Parts List. If it is an electrical part, also give its circuit number.
2. The instrument type (Type 1S1).
3. The instrument Serial Number.

### Soldering Techniques

**Etched-Wiring Boards.** Use ordinary 60/40 tin-lead solder with a 35- to 40-watt pencil-type soldering iron. A hotter type of iron may separate the etched-wiring material from the laminate base. The tip of the iron should be clean and properly tinned for quick heat transfer to the solder joint. The following technique is suggested for replacing a component on an etched-wiring board:

#### Removal:

1. Grip one lead of the component with a pair of long-nosed pliers or a pair of tweezers. (If the component is known to be defective, the leads may be cut near the body of the component for individual removal.)
2. Touch the tip of the soldering iron to the lead at the solder connection (see Fig. 4-1). When the solder begins to melt, pull the lead out gently.
3. Remove each of the other leads in the same manner.

#### Installation:

1. Bend the leads of the new component to match the holes in the board. If the holes are not open, they can be opened by heating the solder to the melting point and quickly inserting a pointed tool or toothpick into the hole.
2. Clip the lead lengths of the new component to the same lengths as the leads of the component that was removed.
3. Insert the leads into the board and position the component properly with respect to the board.
4. Heat-shunt each lead by holding it with long-nosed pliers while applying a small amount of solder to the connection.
5. Clean the area around the solder connection with a flux-removing solvent. Be careful not to remove any information printed on the etched-wiring board.

**Metal Terminals.** When soldering to metal terminals such as connector jacks and switch terminals, ordinary 60/40 tin-lead solder can be used. The soldering iron should have a 40- to 75-watt rating and a 1/8th-inch chisel-shaped tip. Observe the following precautions:

1. Apply only enough heat to make the solder flow freely.
2. If the leads of small components are being soldered to the terminals, be sure to heat-shunt the leads with long-nosed pliers.
3. Apply only enough solder to form a solid connection. Excess solder may impair the function of the part.
4. If excess wire extends beyond the completed solder joint, clip it off and remove it.

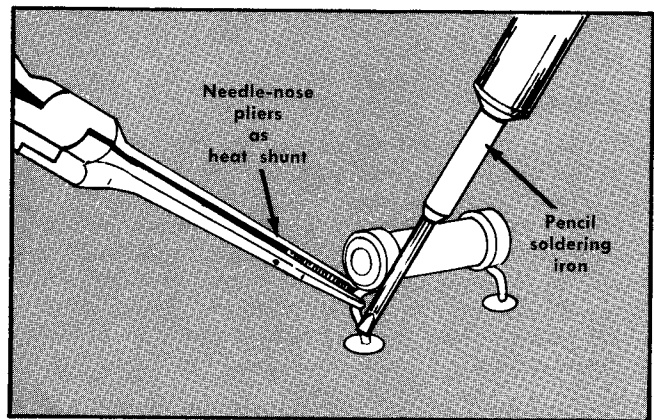

Fig. 4-1. Apply soldering iron to the heat-shunted lead when removing a component from an etched-wiring board.

### Replacement Procedures

**Etched-Wiring Board Removal.** If one of the etched-wiring boards is damaged and cannot be repaired, the board will need to be replaced. When replacing a defective board, the entire assembly including the soldered-on components should be replaced. Part numbers for the replacement board assemblies are given in the mechanical Parts List.

The following procedure is suggested for replacing the etched-wiring boards:

#### Removal:

1. Disconnect all coax mini-jack connectors (if any) from the board.
2. If the Vertical board is being replaced, remove the shield covering the blocking-oscillator circuit (Q80 and SNAP-OFF CURRENT control R85) and remove the two tubes extending through the chassis.
3. Heat-shunt and unsolder all wires connected to the board.
4. Remove all screws holding the board to the chassis frame.
5. Lift the etched-wiring board out of the instrument. Do not force or bend it.

**Installation:**

1. Reverse the order of removal to install a new etched-wiring board.

2. Resolder all wires to the board according to the soldering technique described previously. Wire locations and color-coding of all wires are shown in Figs. 4-3, 4-4 and 4-5.

**Gate Diodes.** The diodes in the sampler gate and memory gate are special gallium arsenide diodes manufactured by Tektronix. The sampler gate diodes occasionally cause poor risetime or system noise. The memory gate diodes sometimes cause memory dot slash. None of these diodes should be replaced, however, unless all other possible sources of trouble have been eliminated. Close matching is required and several of the critical characteristics of the system are affected.

Each diode has a colored dot on the cathode end. The color of the dot identifies its use in the instrument, as indicated in Table 4-1.

The circuit number and polarity of each diode is shown on the schematic diagram and is also marked on the etched-wiring board near the diode mounting assembly.

If it is necessary to remove or replace any of the gallium arsenide diodes, use a pair of tweezers or a tweezer-type tool. Do not solder the diodes into their clips.

**Table 4-1**  
Gallium Arsenide Diodes

Dot Color	Circuit Number	Tektronix Part No.
Yellow	D11B, D11C	152-0216-00*
Orange	D11A, D11D	
Red	D110, D112 (pair)	152-0083-00

\* Supplied by Tektronix as two matched pairs.

**Rotary Switches.** Individual parts or sections of rotary switches normally are not replaced separately. If a switch is defective, the entire assembly should be replaced. Order the switch either with or without the associated components wired in place. Part numbers are given in the electrical portion of the Parts List.

Tag the leads and switch contacts with corresponding identification tags as the leads are disconnected, then use the old switch as a model for installing the new one. When soldering the leads to the new switch, do not let the solder flow beyond the rivet on the switch terminal. Spring tension of the switch contact will be destroyed by excess solder.

## TROUBLESHOOTING

This portion of the Maintenance section is provided to aid in locating and correcting trouble in the Type 1S1. Information contained in the circuit description, the calibration procedure and the schematic diagrams is also helpful when troubleshooting the instrument.

### Troubleshooting Aids

**Diagrams.** Circuit schematic diagrams are given on fold-out pages in Section 6. The circuit numbers and electrical

values of all components, as well as significant voltages and waveforms, are shown on the diagrams. All front-panel and internal control names are given and all coax connectors and input and output leads are indicated. The components of each subcircuit are assigned related circuit numbers so they can be easily located on the diagram.

The sections of rotary switches are coded on the diagrams to indicate the physical positions of the switch contacts. The sections are numbered from the front panel to the rear of the assembly. If two switches (such as the TIME/CM and TIME POSITION RANGE) are mounted as a single unit, a single sequence of numbers is used for the entire assembly. The letters F and R indicate whether the front or rear of the section is used to perform the particular switching function. For example, 3R refers to the rear side of the third switching section back from the front panel.

**Etched-Wiring Boards.** Due to the high-density spacing of components on the etched-wiring boards, only a few component circuit numbers are printed on the boards. However, all components and connections on the boards are shown in Figs. 4-3 through 4-5. Test points can be located where they connect to one or more of the components.

**Wiring Color-Code.** All insulated wire in the Type 1S1 is color-coded for convenience in circuit tracing. Signal-carrying leads are identified with one or two colored stripes. Voltage-supply leads are coded with three stripes to indicate the approximate voltage carried by the lead, using the standard EIA resistor color code. The code is read starting with the widest stripe and proceeding in order of decreasing width. A white background indicates a positive voltage and a tan background indicates a negative voltage. As an example, coding on the -19-volt lead is red (widest stripe), black and black (narrowest stripe) on a tan background. Note that this coding reads -20 volts, which is the closest value that can be easily identified with the color code.

**Resistor Color-Code.** In addition to the brown composition resistors, some metal-film resistors (identifiable by their gray body color) are used in the Type 1S1. Both of these types are coded for resistance value with the EIA color-code, which is read starting with the stripe nearest the end of the resistor. The composition resistors have four stripes which consist of two significant figures, a multiplier and a tolerance value. The metal-film resistors have five strips which consist of **three** significant figures, a multiplier and a tolerance value. The values of wire-wound resistors (light blue or gray-green) are marked on the body of the component.

### Troubleshooting Techniques

The following procedure is arranged in a sequence to check operational troubles before proceeding with extensive troubleshooting. If the trouble is not located by the checks, the remaining steps will help locate the defective part or parts. When replacing any defective parts, follow the replacement procedures described earlier in this section.

**1. Check Control Settings.** Incorrect control settings can indicate trouble that does not exist. For example, incorrect setting of the triggering controls for the particular input signal may seem to indicate a defective trigger circuit. If there is any question about the correct purpose and use of

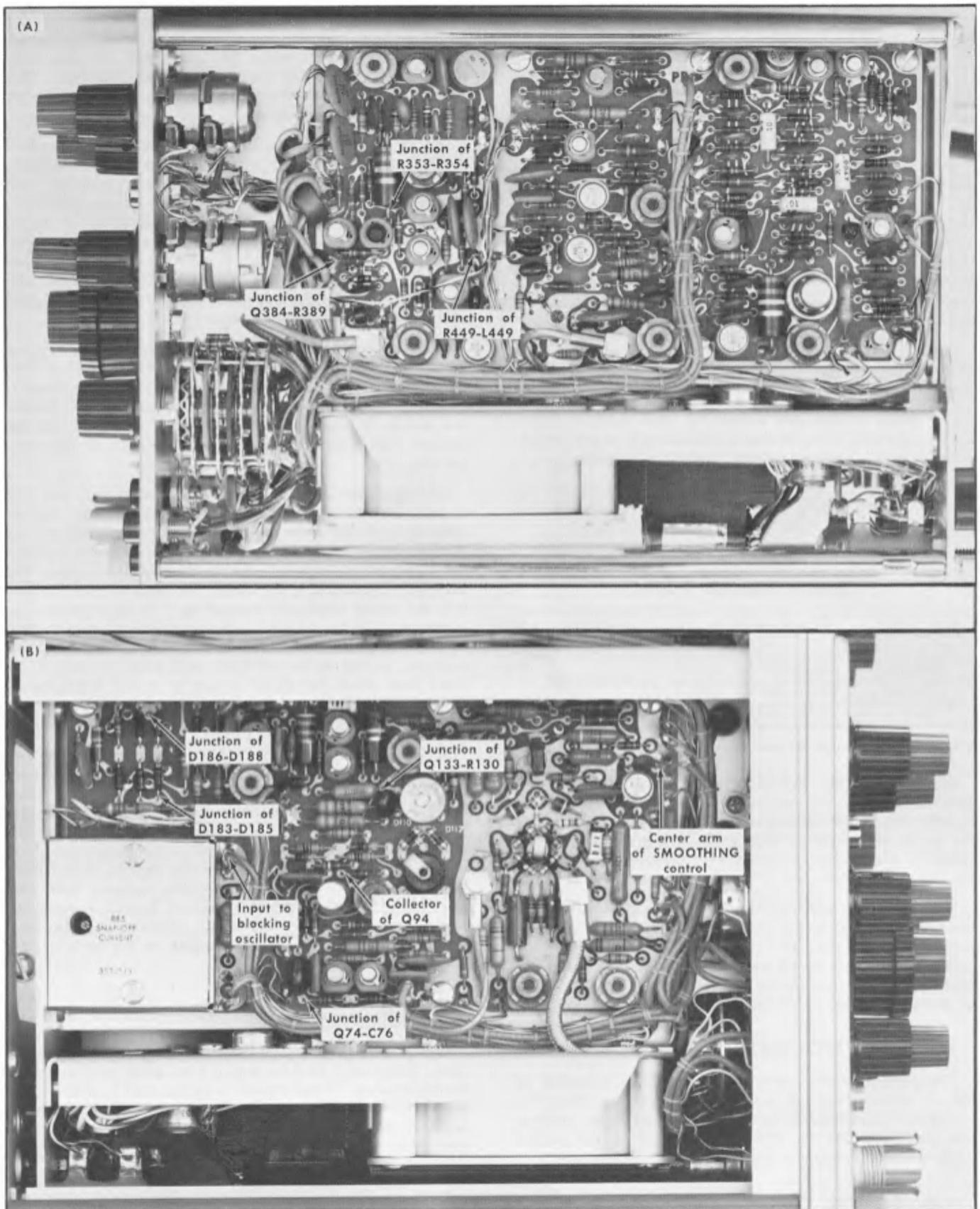

Fig. 4-2. Basic test points used for troubleshooting the Type 151. (A) Horizontal system on right side of unit; (B) vertical system on left side of unit.



a control, refer to the Operating Instructions section of this manual.

A display that may appear as a circuit trouble to an operator not familiar with sampling can occur if the triggering signal is interrupted during a sweep. Since each dot in the crt display is the result of a sampling event that follows a triggering event, if the triggering information stops, sampling also stops immediately. If the sweep has not been completed, the spot remains on the crt, but drifts up or down and finally goes out of sight. This is normal and should not be confused with trouble in the Type 1S1. It is caused by the memory output drifting without the repeated correction that occurs when samples are taken. If the triggering information begins again, the dots will begin again and the interrupted sweep will be completed.

**2. Check Associated Equipment.** Before troubleshooting the Type 1S1, be sure that the equipment used with it is operating correctly. Check that the input cables or probes are not defective. If another plug-in unit is available, substitute it in the oscilloscope and check that the oscilloscope is operating properly. Check the oscilloscope power-supply voltages with the Type 1S1 out of the oscilloscope, then again with the Type 1S1 installed.

**3. Check Instrument Calibration.** The calibration procedure in Section 5 of this manual provides a step-by-step check of the various circuits, and usually will indicate the location of the trouble. The indicated trouble may only be the result of a misadjustment and may be corrected by calibration. If individual calibration steps are performed out of sequence, remember that any change in adjustment settings will affect subsequent steps of the procedure.

**4. Isolate the Trouble to a Circuit.** If the trouble has not been corrected or isolated to a particular circuit with the preceding steps, make the following checks if possible.

a. Check for the correct resistance readings at the interconnecting plug terminals, as indicated in Table 4-2.

**TABLE 4-2**

Interconnecting Plug Resistance Checks  
(Type 1S1 disconnected from oscilloscope)

Pin Number	Resistance to ground ( $\pm 20\%$ )	Resistance to ground ( $\pm 20\%$ ) Leads reversed.
1	42 k $\Omega$	20 k $\Omega$
2	0	0
3	28 k $\Omega$	20 k $\Omega$
4	infinite	infinite
5	infinite	infinite
6	infinite	infinite
7	infinite	infinite
8	6.3 k $\Omega$	*
9	4.0 k $\Omega$	5.6 k $\Omega$
10	7.6 k $\Omega$	7.3 k $\Omega$
11	5.3 k $\Omega$	5.3 k $\Omega$
12	210 k $\Omega$	210 k $\Omega$
13	infinite	infinite
14	infinite	infinite
15	1.1 k $\Omega$	*
16	370 k $\Omega$	370 k $\Omega$

\* Depends on the meter scale used.

b. Check the input dc resistance of the SIGNAL IN connector between the center conductor and the outer conductor (chassis ground) while the instrument power is turned off. Resistance measured with an accurate bridge ( $\pm 0.5\%$ ) should be 49.0 ohms  $\pm 1.0$  ohm.

c. Check for voltages and waveforms with the instrument turned on. Typical voltages and waveforms, given on the schematic diagrams, were obtained under the test conditions listed on the left page of the Sampler circuit diagram. Voltage measurements should be made with a 20,000 ohms/volt dc voltmeter, accurate to within 3% on all ranges. Insulate the test prods to prevent accidental shorting. Check for waveforms with a 30-Mc test oscilloscope and a 10 $\times$  probe (approximately 10-megohm input resistance). The Type 1S1 is operated on a plug-in extension cable (Tektronix Part Number 012-0038-00) for convenience of access to all parts of the circuitry. The trigger circuit is operated in free run to provide waveforms in all circuits.

d. If it is not possible to obtain a trace or spot on the crt screen, the following sequence may help to isolate the trouble quickly:

Set the following Type 1S1 controls as indicated:

TIME/CM	50 nSEC
SAMPLES/CM	MIN (clockwise)
TRIGGER SENSITIVITY	Clockwise
TRIGGER SOURCE	FREE RUN

See Fig. 4-2 for the test points mentioned in the procedure.

**Horizontal System.** Check for a staircase waveform at the front-panel HORIZ OUTPUT jack. If the staircase waveform is present, the horizontal system is operating. In this case, proceed with the vertical system checks given below.

If the staircase waveform is not present at the HORIZ OUTPUT jack, set the EXT HORIZ ATTEN control fully clockwise and apply a 10-volt calibrator waveform to the EXT HORIZ INPUT jack. Check for the calibrator waveform at the HORIZ OUTPUT jack.

If the calibrator waveform is present at the HORIZ OUTPUT jack, check the staircase inverter output for a calibrator waveform at the junction of Q384 and R389.

If the calibrator waveform is present at the staircase inverter output, check the trigger circuit output for a normal free run waveform at the junction of R449 and L449. See the trigger schematic diagram for the correct waveform.

If the free run waveform is present, set the TRIGGER SOURCE switch to INT+ and the TRIGGER SENSITIVITY control fully clockwise and check again for the waveform.

If the trigger output waveform is correct, check for a comparator output waveform at the junction of R353 and R354. See the fast ramp schematic diagram for the correct waveform.

**Vertical System.** Check the input to the blocking oscillator for a drive pulse as shown on the sampler schematic diagram.

If the drive pulse is present, check the operation of the blocking oscillator and memory gate driver by observing

## Maintenance—Type 1S1

the waveform at the junction of Q94 and R98. See the sampler schematic diagram for the correct waveform.

If the blocking oscillator is operating, set the mVOLTS/CM switch to 5 and observe the sampler preamplifier output waveform at the center arm of the SMOOTHING control as the DC OFFSET control is rotated throughout its range. The polarity of the pulses should change as the control is rotated.

If the sampler preamplifier waveform changes polarity as indicated, observe the ac amplifier output waveform at the junction of Q74 and C76 as the DC OFFSET control is rotated through its range. The pulses should reverse polarity.

If the ac amplifier output waveform changes as described, check the dc level of the memory output at the junction of Q133 and R130 as the DC OFFSET control is rotated. The dc level should change polarity as the control is turned through its range.

If the memory output changes polarity as the DC OFFSET is rotated, check the vertical outputs to the oscilloscope at the junction of D183 and D185 and at the junction of D186 and D188 for a dc level between +64.5 volts and +69.5 volts.

**5. Check the Circuit Visually.** After isolating the trouble to a particular circuit, check the circuit for damaged parts or broken connections. Often a visual inspection can indicate the source of trouble.

**6. Check Individual Components.** Components that are soldered in place can be checked most easily by unsoldering one end. This eliminates incorrect measurements due to the effects of surrounding circuitry.

**Transistors and Electron Tubes.** Most circuit failures result from the failure of a transistor or tube due to normal aging and use. The recommended method of checking a transistor or tube is by direct substitution, since static-parameter testers do not indicate the circuit performance of a component. A dynamic tester such as a Tektronix Type 575 (for transistors) or Type 570 (for tubes) Curve-Tracer Oscilloscope may also be useful for checking a transistor or tube that is suspected of being defective. Before installing a replacement, be sure that the circuit voltages are not abnormal. If these voltages are not checked, the new component may be damaged by a defective circuit.

**Tunnel Diodes.** A dynamic tester such as a Type 575 Curve-Tracer Oscilloscope can be used for checking the operation of a tunnel diode. The component must be removed from the circuit before it can be checked in this manner.

### CAUTION

Do not use an ohmmeter for checking tunnel diodes. The low-impedance current source from the ohmmeter exceeds the current capabilities of most tunnel diodes.

**Diodes.** Ordinary semiconductor diodes can be checked for an open or shorted condition by measuring the resistance between terminals. With an ohmmeter scale using an internal source of 3 volts or less, the resistance should measure very high in one direction and very low with the leads reversed.

### CAUTION

Do not use an ohmmeter scale that uses a high-voltage source. If the junction breakdown voltage is exceeded, the reading will not be correct and the diode may be damaged.

**Resistors.** Check resistor values with an ohmmeter or resistance bridge. The tolerance permitted for each resistor used in the instrument is given in the Parts List. The measuring device must have a tolerance considerably more severe than the tolerance of the resistor being measured, in order to make a valid determination. However, it is usually not necessary to replace a resistor unless the value is far out of tolerance.

**Inductors.** An ohmmeter may be used to check an inductor for an open condition. A shorted or partially shorted inductor can often be found by checking waveforms in the circuit. To determine the value of the inductor, however, an inductance meter is required.

**Capacitors.** A leaky or shorted capacitor can be detected by checking it with an ohmmeter set to a high scale. (Do not exceed the voltage rating of the capacitor.) The resistance reading should be infinite after the capacitor has charged. An open capacitor can be detected with a capacitance meter or by trying to pass an ac signal through it.

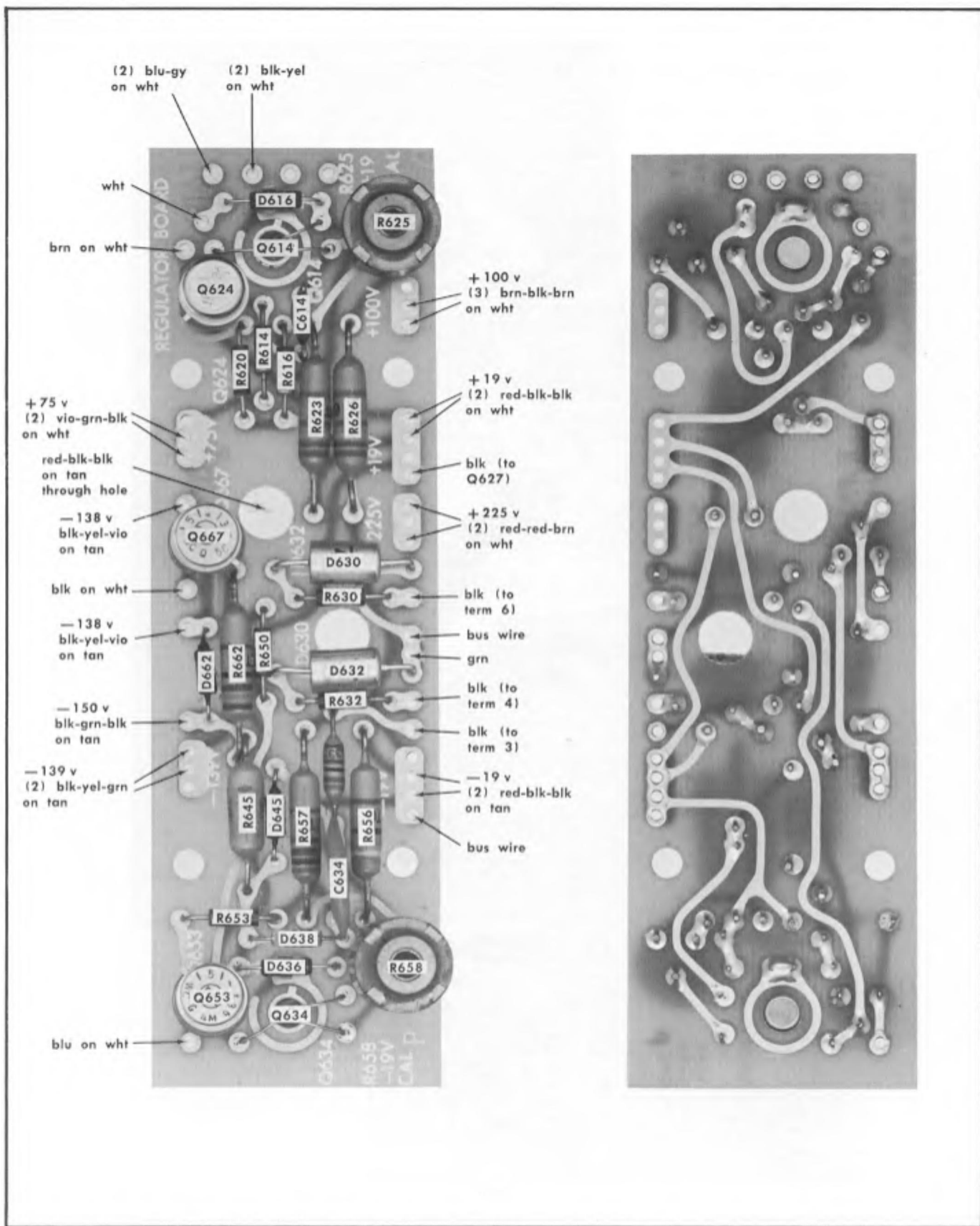

Fig. 4-3. Circuit component locations and wiring color-code on etched-wiring REGULATOR BOARD: (A) front side; (B) reverse side.

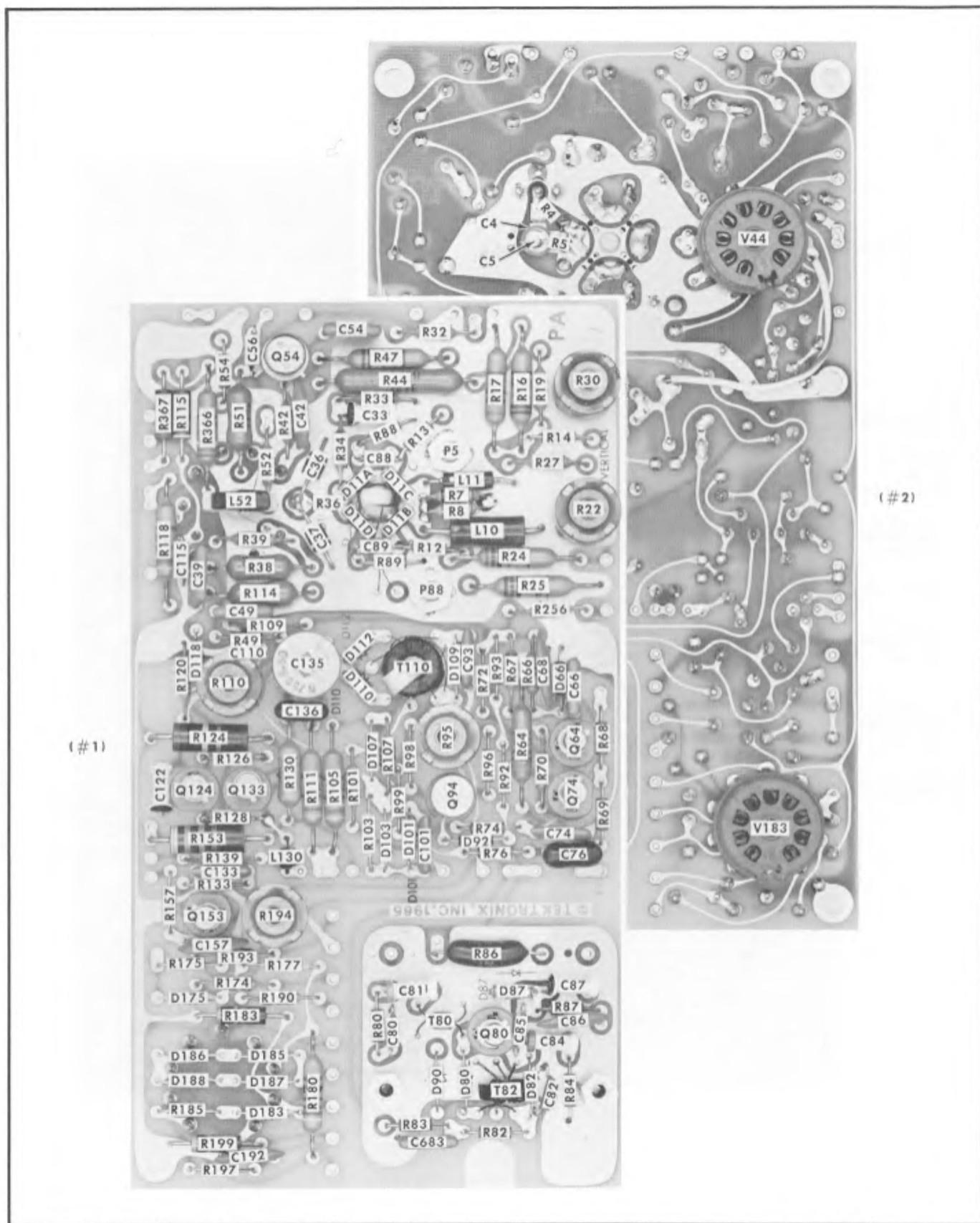

Fig. 4-4A. Circuit component locations on VERTICAL etched-wiring board: (#1) Front side; (#2) reverse side.

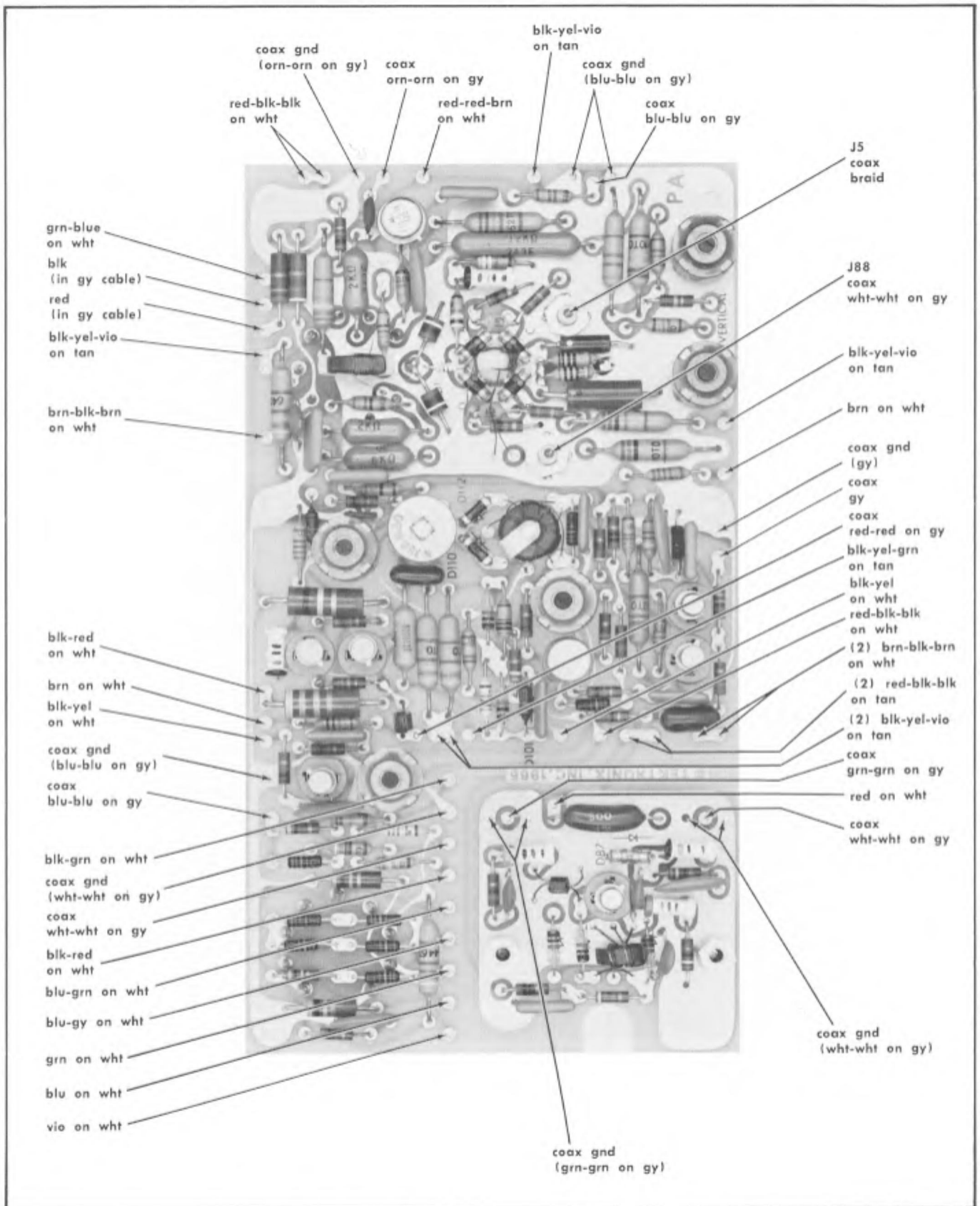

Fig. 4-4B. Wiring color code on VERTICAL etched-wiring board.

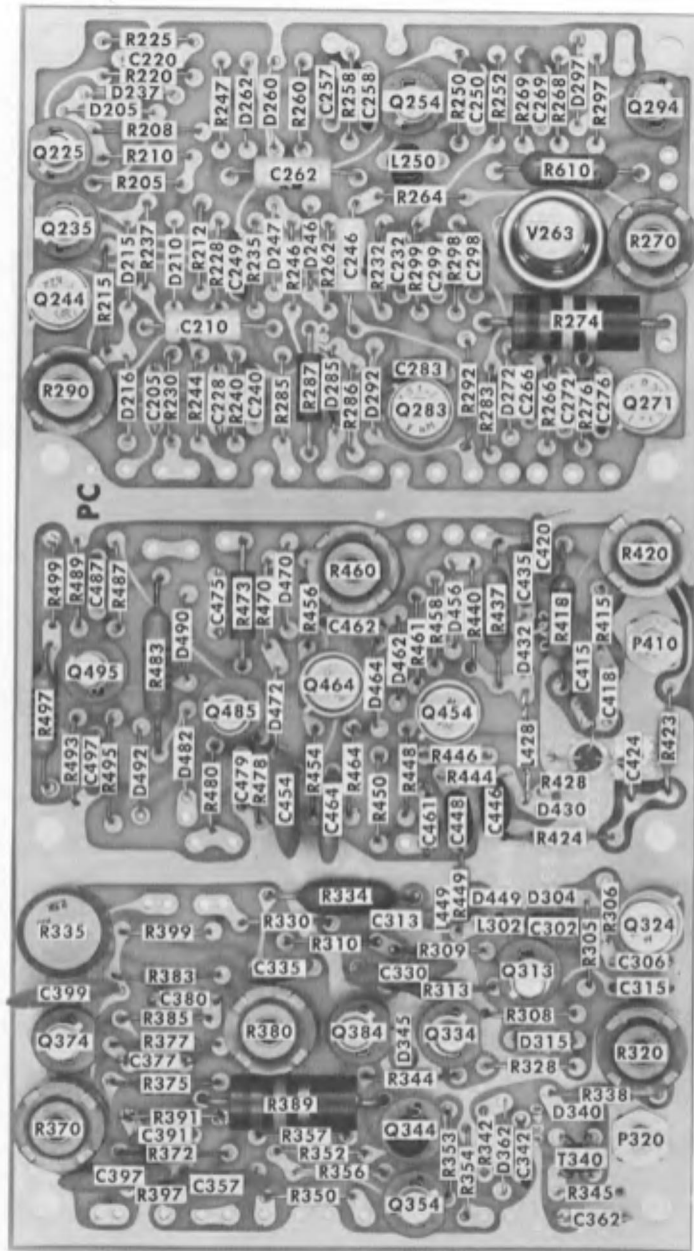

Fig. 4-5A. Circuit component locations on front side of HORIZONTAL etched-wiring board.



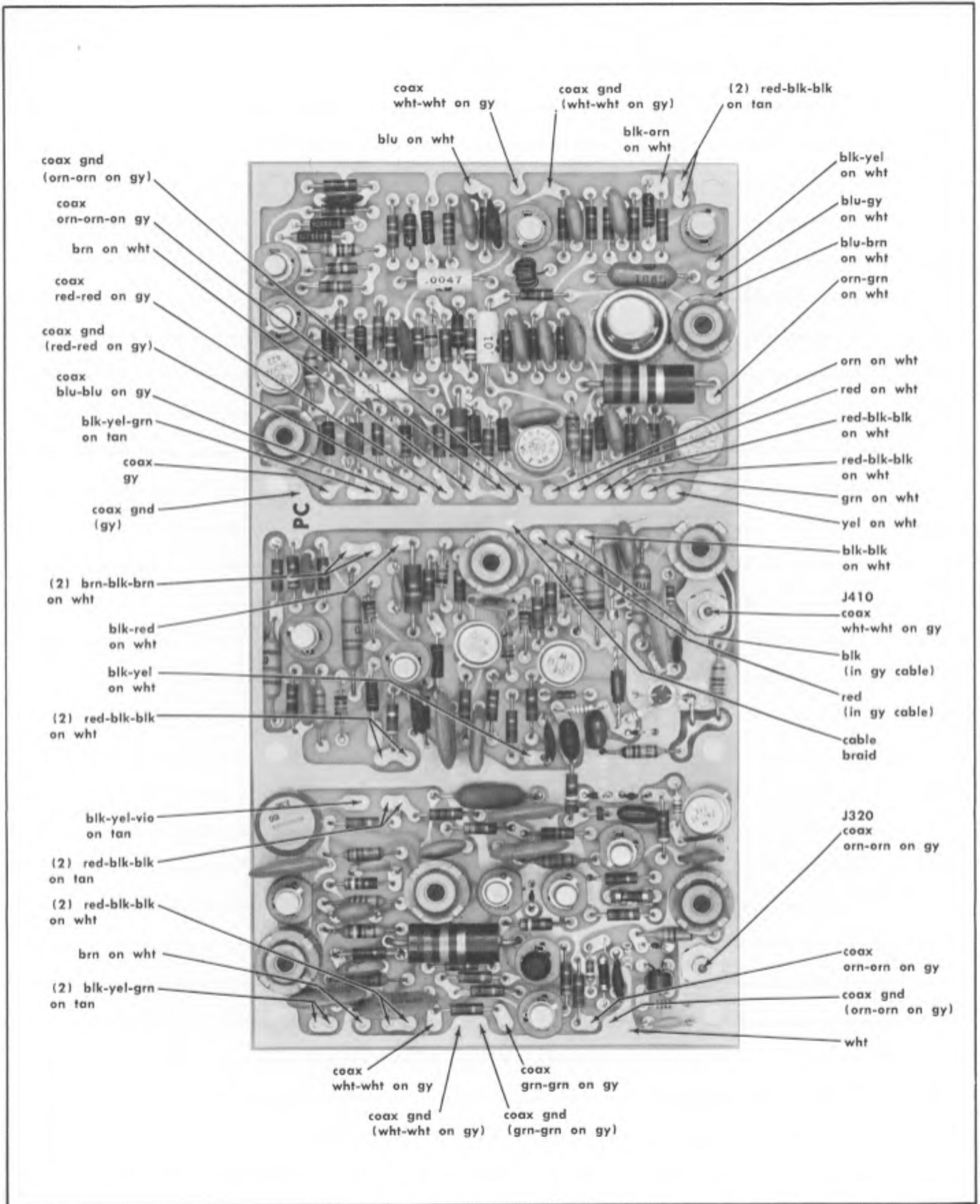

Fig. 4-5B. Wiring color code on HORIZONTAL etched-wiring board.





# SECTION 5

## CALIBRATION

### General Information

A complete calibration and verification procedure for the Type 1S1 is provided in this section. This procedure checks the instrument to the performance characteristics given in Section 1. A calibration outline is included at the beginning of the procedure for use as a guide for quick calibration by an experienced calibrator, or as a checklist to verify correct calibration and operation of the Type 1S1.

The Type 1S1 should be checked and recalibrated after each 500 hours of operation, and at least once every 6 months, to insure that it is operating properly and accurately. In addition, portions of the instrument will require recalibration if components have been replaced or other electrical repairs have been made in the circuitry.

The step-by-step instructions in the calibration procedure furnish an orderly approach to the isolation of possible malfunctions, and thus serve as an aid in troubleshooting and repairing the instrument. Any maintenance that is known to be needed should be performed before starting the calibration procedure. If any troubles become apparent during calibration, these should also be corrected before proceeding. Repair and servicing information is given in Section 4 of this manual.

Specialized calibration equipment is used wherever applicable to provide the quickest and most accurate calibration. If this equipment is not available, substitute equipment must equal or exceed the requirements listed below under "Equipment Required." If the equipment does not meet these requirements, the Type 1S1 may not be calibrated to the given accuracy. In such a case, the difference between the specified equipment accuracy and the accuracy of the equipment used must be added to the tolerance stated in the calibration step.

### EQUIPMENT REQUIRED

The following (or equivalent) items of equipment are required for a complete calibration of the Type 1S1. The equipment is illustrated in Figs. 5-1 and 5-2.

1. Calibrated indicator oscilloscope, Tektronix Type 545B. Alternate equipment requirements: Compatible with Tektronix 1-series plug-in units; external horizontal input with deflection factor adjustable to 1 volt/cm; amplitude calibrator output waveform (approximately 1 kc); 6-cm by 10-cm crt screen desirable.

2. Calibrated test oscilloscope, Tektronix Type 545B with Type W Differential Comparator Plug-In Unit. Minimum alternate requirements: Bandpass from dc to 15 Mc; sweep rates from 10 msec/cm to 0.2  $\mu$ sec/cm; vertical input deflection factors from 500 mv/cm to 1 mv/cm; voltage and timing accuracy of display within 3%; internal comparison voltage with Vc accuracy within 0.5%; ac and dc vertical input coupling; internal and external triggering capability. A single vertical input channel is used.

3. Time-mark generator, Tektronix Type 180A. Minimum alternate requirements: Marker outputs from 1  $\mu$ sec to 50  $\mu$ sec; sine-wave outputs of 5 Mc, 10 Mc and 50 Mc; frequency accuracy within 0.25%; marker and sine-wave amplitudes at least 400 mv into 50 ohms.

4. Pretrigger pulse generator, Tektronix Type 111. Minimum alternate requirements: Output pulse risetime less than 1 nsec; output pulse amplitude at least 2 volts into 50 ohms; output pulse duration 2 nsec and 9 nsec (with charge line); pretrigger pulse amplitude at least 100 mv into 50 ohms; pretrigger to output pulse time delay variable from 30 nsec to 250 nsec; repetition rate variable from 10 cps to 100 kc.

5. Tunnel diode pulse generator, Tektronix 067-0513-00. Minimum alternate requirements: Pulse risetime 30 psec or less; pulse amplitude at least 400 mv into 50 ohms; pulse duration approximately 40 nsec; repetition rate approximately 70 kc.

6. 50  $\Omega$  Amplitude calibrator, Tektronix 067-0508-00. Minimum alternate requirements: Output amplitude from 12 mv to 2.0 volts into 50 ohms; amplitude accuracy within 0.5%; output frequency approximately 20 kc.

7. Square-wave generator, Tektronix Type 105. Minimum alternate requirements: Output frequency adjustable to 150 kc; risetime approximately 20 nsec; aberrations after rise less than 1%; output amplitude adjustable to 1 volt into 50 ohms, using attenuators if necessary.

8. 1-Gc sine-wave generator (e.g. General Radio Type 1218-A Oscillator with Type 1201-B or Type 1203-B Power Supply). Minimum requirements: Output frequency 1 Gc; frequency accuracy within 1% at 1 Gc; peak-to-peak output amplitude at least 800 mv into 50 ohms.

9. 100-kc Audio generator (e.g. Heathkit Model IG-72). Minimum requirements: Output frequency 100 kc; peak-to-peak output amplitude at least 300 mv into 50 ohms.

10. Variable autotransformer (e.g. General Radio, Variac Type W10MT3W). Required only for checking voltage regulation. Minimum requirements: Output voltage variable over regulation range of indicator oscilloscope (e.g. 105 volts to 125 volts ac rms for nominal 117-volt operation); output power rating at least 0.6 kva. If autotransformer does not include ac voltmeter for monitoring output voltage, separate ac voltmeter is required. Accuracy of meter must be within 3% over the required range.

11. Resistance bridge (e.g. Electro-Scientific Industries 250-DA Impedance Bridge). Required only for checking input dc resistance. Accuracy within at least 0.5% at 49 ohms.

12. 10X Attenuator probe for test oscilloscope, Tektronix P6006. Tektronix part number 010-0127-00 (BNC connector).

13. 1X probe for test oscilloscope, Tektronix P6028. Required for measuring dc voltages and power supply ripple.

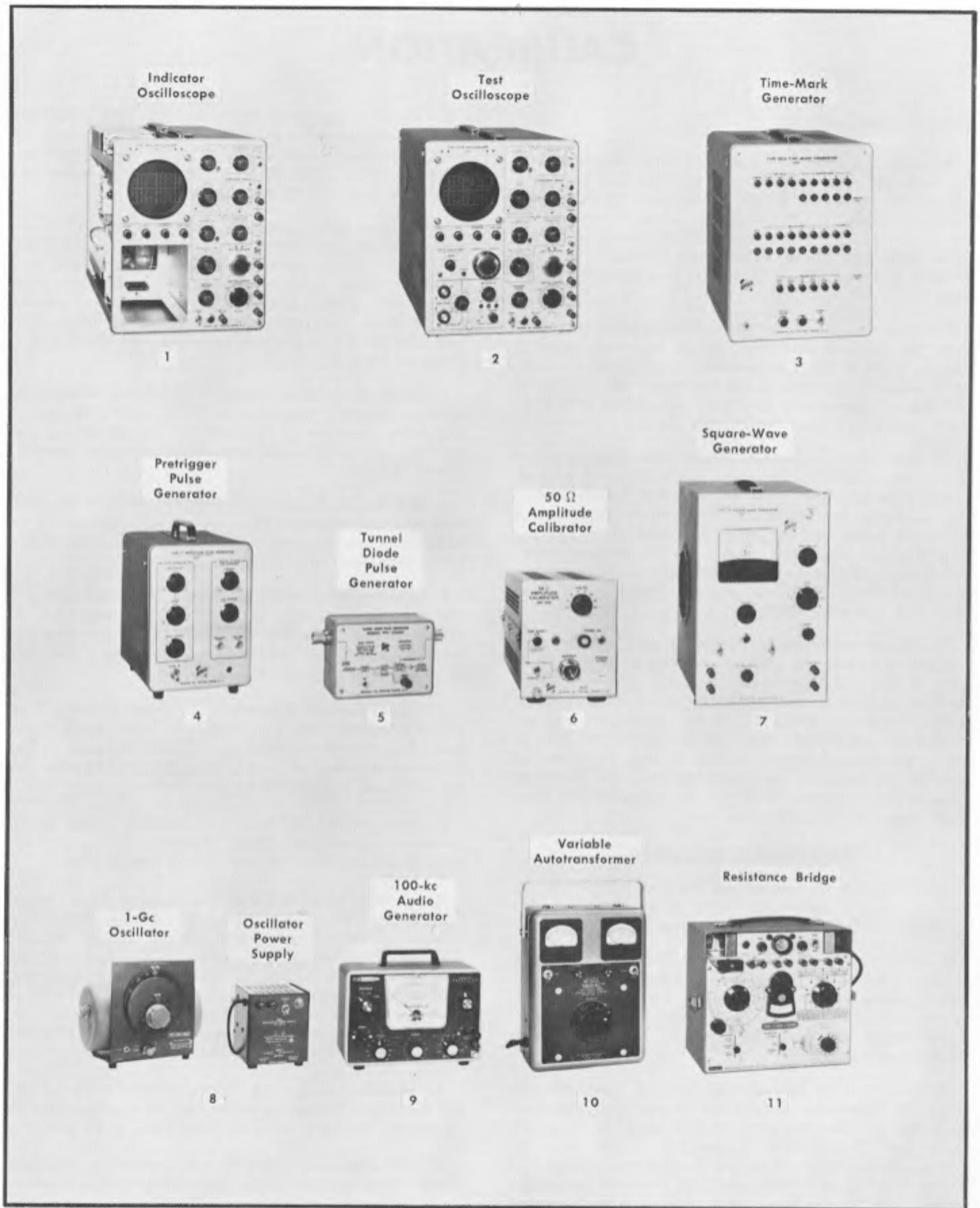

Fig. 5-1. Recommended calibration equipment.

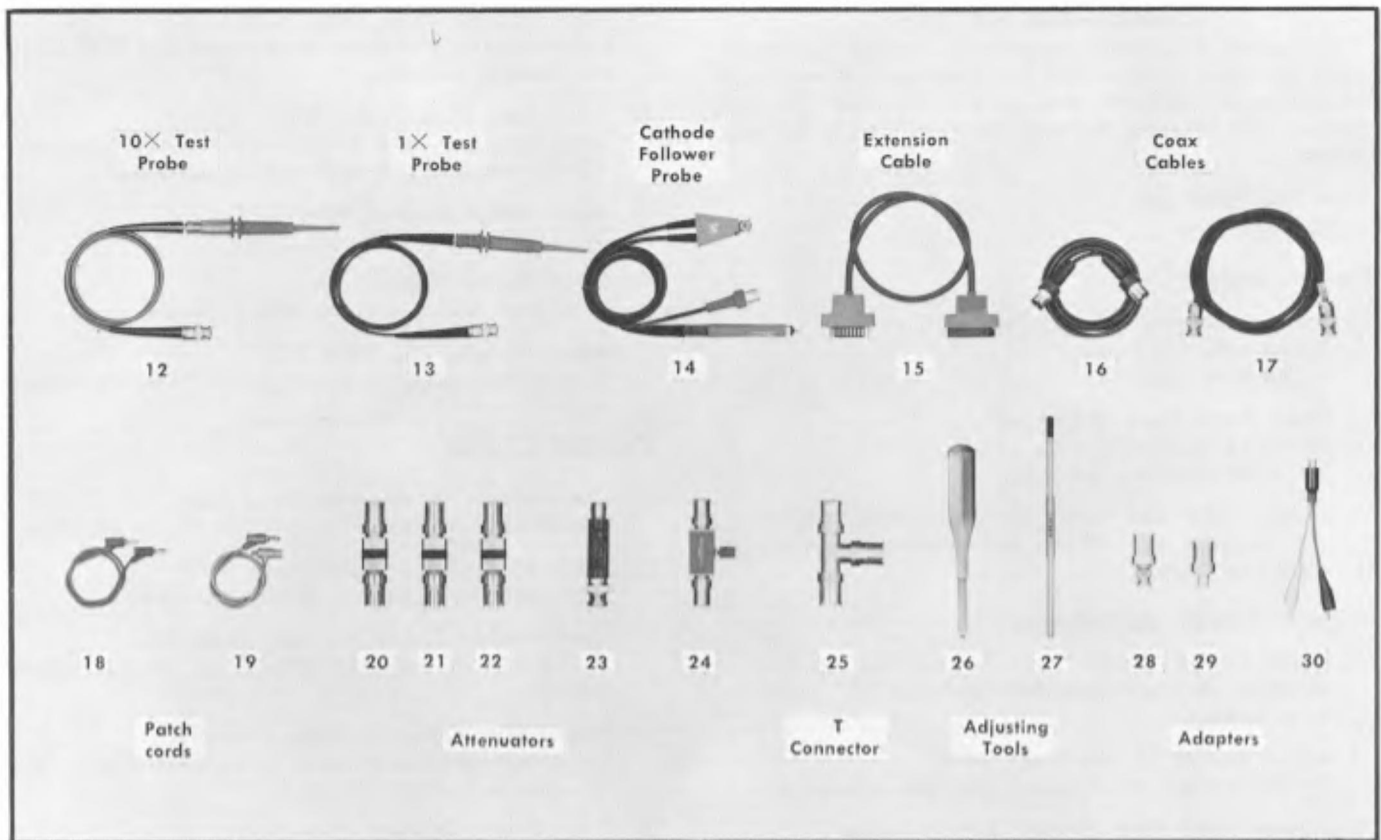

Fig. 5-2. Small calibration equipment and tools.

Series resistance approximately 200 ohms. Tektronix part number 010-0120-00.

14. Cathode-follower probe, Tektronix P6032. Minimum alternate requirements: Compatible with Type 1S1 PROBE POWER connector. Required only for loading PROBE POWER connector during voltage checks. A 70-ohm 5-watt resistor may be substituted for the probe.

15. 30-inch flexible 1-series plug-in extension cable. Tektronix part number 012-0038-00.

16. 10-nsec coaxial cable (RG-58A/U) with GR 50-ohm connectors. Tektronix part number 017-0501-00.

17. 42-inch coaxial cable with BNC connectors. Characteristic impedance approximately 50 ohms. Tektronix part number 012-0057-00.

18. Two 18-inch patch cords with banana connectors on both ends. Tektronix part number 012-0024-00.

19. Two 18-inch patch cords with BNC connector on one end and banana connector on other end.

20. Four 10X T-attenuators with GR 50-ohm connectors. Tektronix part number 017-0044-00.

21. Two 5X T-attenuators with GR 50-ohm connectors. Tektronix part number 017-0045-00.

22. 2X T-attenuator with GR 50-ohm connectors. Tektronix part number 017-0046-00.

23. 2X T-attenuator with BNC connectors. Tektronix part number 011-0069-00.

24. Variable attenuator with GR 50-ohm connectors. Tektronix part number 067-0511-00. Fixed attenuators, as required, may be substituted.

25. Coaxial T-connector with GR 50-ohm connectors. Tektronix part number 017-0069-00.

26. Plastic screwdriver-type adjustment tool. Shaft length  $1\frac{1}{2}$  inches. Tektronix part number 003-0000-00.

27. Plastic tool with recessed screwdriver tips. Length 7 inches. Tektronix part number 003-0003-00 or Walsco 2519.

28. GR-to-BNC plug connector adapter. Tektronix part number 017-0064-00.

29. GR-to-BNC jack connector adapter. Tektronix part number 017-0063-00.

30. Clip-lead adapter with BNC jack connector. Required only for checking input dc resistance. Tektronix part number 013-0076-00.

31. Other connector adapters as required for adapting between connector types.

### CALIBRATION OUTLINE

This outline is provided to serve as a quick calibration guide for those familiar with the procedure. It may also be used as a verification and calibration record. The step numbers and titles are the same as those used in the procedure.

Type 151 Serial No. \_\_\_\_\_

Calibration Date \_\_\_\_\_

#### Power Supply

1. Adjust Regulated Voltages (Page 5-7)
  - −19.0 volts  $\pm 0.5$  volt;
  - +19.0 volts  $\pm 0.5$  volt.
2. Check Probe Power (Page 5-8)
  - (B) −12.6 volts  $\pm 0.6$  volt;
  - (D) +100 volts  $\pm 1$  volt.
3. Check −19 V and +19 V Regulation (Page 5-8)
  - $\leq 5$  mv ripple on −19-volt and +19-volt supplies over regulation range.

#### Trigger Circuit Adjustments

4. Adjust Internal Trigger Level (Page 5-11)
  - Midrange of trigger sensitivity operation 45° clockwise from center.
5. Adjust Control TD Bias (Page 5-11)
  - Correct current for triggered and sync operation.

#### Staircase and Fast Ramp Adjustments

6. Adjust Staircase DC Level (Page 5-13)
  - Zero volts at base of staircase.
7. Adjust Inverter DC Zero (Page 5-13)
  - Zero volts at inverter input with Delay Zero at zero volts.
8. Adjust Timing Cal (Page 5-15)
  - Horizontal deflection of 1 volt/cm  $\pm 1\%$ ;
  - Correct timing within 1% at 5 msec/cm.
9. Adjust Comparator Level (Page 5-16)
  - Correct operation of comparator circuit.
10. Adjust 50 nS Ramp Timing (Page 5-17)
  - Correct timing within 1% at 5 nsec/cm.
11. Adjust Delay Zero (Page 5-20)
  - 4 nsec of display delay on 500 nS time position range.
12. Adjust Sweep Length (Page 5-20)
  - Approximately 10.2 cm.
13. Check Input Dc Resistance (Page 5-21)
  - 49 ohms  $\pm 1$  ohm.

#### Vertical Adjustments

14. Adjust Memory Balance (Page 5-23)
  - No trace movement with SMOOTHING control change.
15. Adjust Bridge Balance (Page 5-23)
  - No trace movement with mVOLTS/CM switch change (offset at zero volts).
16. Adjust Variable Balance (Page 5-24)
  - No trace movement with mVolts/Cm VARIABLE control change (offset at zero volts).

17. Adjust Position Range (Page 5-24)
  - Trace centered with offset at zero volts and VERT POSITION control midrange.
18. Adjust Loop Gain (Page 5-27)
  - Unity loop gain with SMOOTHING control clockwise;
  - $\leq 2$  mm baseline shift with polarity reversal.
19. Adjust Bridge Standoff (Page 5-29)
  - $\geq +2$  volts using a 20-nsec pulse.
20. Adjust Risetime (Page 5-30)
  - $\leq 350$  psec display risetime using a 30-psec pulse.
21. Adjust Vertical Gain (Page 5-33)
  - Correct input deflection factor within 3% at 200 mv/cm.

#### Vertical Checks

22. Check mVolts/Cm Accuracy (Page 5-33)
  - Correct input deflection factor within 3% on all ranges.
23. Check mVolts/Cm Variable (Page 5-33)
  - $\geq 4:1$  increase in vertical display deflection.
24. Check Vertical Output Accuracy (Page 5-35)
  - 200 mv ( $\pm 3\%$ ) output amplitude per cm of vertical deflection.
25. Check Offset Output Accuracy (Page 5-35)
  - Output voltage change equal to 10 times display voltage change ( $\pm 2\%$ ).
26. Check Output Dc Level (Page 5-36)
  - +67.5 volts  $\pm 2.5$  volts at output to oscilloscope (offset at zero volts).
27. Check Vertical Position Range (Page 5-39)
  - $\geq 10$  cm of vertical positioning with VERT POSITION control.
28. Check DC Offset Range (Page 5-39)
  - $\geq \pm 1.0$  volt of offset voltage.
29. Check Risetime (Page 5-41)
  - $\leq 350$  psec display risetime using a 30-psec pulse.
30. Check Loop Gain (Page 5-41)
  - Unity loop gain with SMOOTHING control clockwise;
  - $\leq 2$  mm baseline shift with polarity reversal.
31. Check Smoothing Control (Page 5-41)
  - $\geq 3:1$  decrease in loop gain with SMOOTHING control counterclockwise;
  - $\leq 1.5$  mm amplitude change with SMOOTHING control counterclockwise.
32. Check Low-Frequency Response (Page 5-42)
  - $\leq 3\%$  low-frequency droop on 150-kc square wave.
33. Check Tangential Noise (Page 5-45)
  - $\leq 1$  mv without smoothing.
34. Check Baseline Shift (Page 5-45)
  - $\leq 4$  mv trace movement with triggering rate change from 100 kc to 20 kc;
  - $\leq 4$  mv trace movement with triggering rate change from 20 kc to 30 cps.
35. Check Memory Drift (Page 5-46)
  - $\leq 1$  cm of dot slash at 10 cps triggering rate.

## Horizontal Checks

36. Check Timing and Linearity (Page 5-49)
  - Correct timing within 1% at 5  $\mu$ sec;
  - Correct 1-2-5 ratio within 1% on 5  $\mu$ S ramp;
  - Correct timing within 1% using magnifiers (from .5  $\mu$ Sec);
  - Correct timing within 1% on each time position range (using "multiple of 5" sweep rate);
  - Correct timing within 3% at each end of time position range, excluding the following: first 2% of fast ramp on 500  $\mu$ S, 50  $\mu$ S, 5  $\mu$ S and 500 nS ranges; first 4% of fast ramp on 50 nS range;
  - Timing linearity within 1% over time position range;
  - (Optional): Correct timing within 3% on all sweep rates from 50  $\mu$ sec/cm to 0.1 nsec/cm.
37. Check Time/Cm Variable (Page 5-52)
  - $\geq 3:1$  increase in equivalent sweep speed.
38. Check Single Sweep (Page 5-52)
  - Triggered single sweep operation.
39. Check Samples/Cm (Page 5-52)
  - 4 to 6 dots/cm with SAMPLES/CM control at minimum;
  - 1 to 30 sec/sweep with SAMPLES/CM control at maximum;
  - Nearly imperceptible dot movement with SAMPLES/CM control at SWEEP OFF position.
40. Check Blanking (Page 5-53)
  - 1.5  $\mu$ sec blanking between dots;
  - Retrace positioned off screen.
41. Check Ext Atten and Manual Scan (Page 5-55)
  - 1 volt/cm ( $\pm 4\%$ ) with EXT HORIZ ATTEN control clockwise;
  - 16 volts/cm with EXT HORIZ ATTEN control counter-clockwise;
  - $\geq 10.0$  cm of scan with MANUAL SCAN control.
42. Check Display Jitter (Page 5-57)
  - $\leq 0.02\%$  of time position ramp on 500  $\mu$ S, 50  $\mu$ S and 5  $\mu$ S ranges;
  - $\leq 0.024\%$  of time position ramp on 500 nS range;
  - $\leq 0.08\%$  of time position ramp on 50 nS range.

## Triggering Checks

43. Check Triggering Jitter (Page 5-57)
  - $\leq 0.7$   $\mu$ sec on 100-kc sine wave, 50 mv internal;
  - $\leq 0.5$   $\mu$ sec on 100-kc sine wave, 4 mv external;
  - $\leq 5$  nsec on 10-Mc sine wave, 50 mv internal, 8 mv external;
  - $\leq 200$  psec on 1-Gc sine wave, 50 mv internal, 8 mv external;
  - $\leq 200$  psec on 2-nsec pulse, 40 mv internal, 7 mv external.
44. Check External Trigger Kickout (Page 5-60)
  - $\leq 25$  mv with TRIGGER SOURCE switch at EXT  $\pm$ .
45. Check Trigger Recovery Time (Page 5-60)
  - 1.8-2.3 msec on 500  $\mu$ S time position range;
  - 200-270  $\mu$ sec on 50  $\mu$ S time position range;
  - 20-27  $\mu$ sec on 5  $\mu$ S time position range;
  - 10-13  $\mu$ sec on 500 nS and 50 nS time position ranges.

## CALIBRATION PROCEDURE

The following procedure is arranged in a sequence that allows the Type 1S1 to be calibrated with a minimum of adjustment interaction. Each step contains complete information for performing that step. The sequence includes procedures for checking performance as well as those required for adjusting the calibration controls. To make only the control adjustments without checking performance of the instrument, perform only the "Adjust" steps and omit the "Check" steps. (The symbol **I** is provided for convenience in locating the "Adjust" steps.) Any equipment connections or control settings that are changed during the omitted steps must be noted and performed if necessary. If any adjustment steps are performed individually or out of sequence, subsequent adjustment steps may also need to be checked, since some adjustments affect the calibration of other circuits.

To identify the two oscilloscopes used in the procedure, the one that is operated in conjunction with the Type 1S1 is called the "indicator oscilloscope" and the one that is used for making waveform and voltage checks is referred to as the "test oscilloscope."

Use a short ground lead on the test probe. Whenever the probe is connected to a test point, clip the ground lead to chassis ground. Failure to ground the probe cable may result in the appearance of ringing on the signal.

Do not preset any calibration adjustments unless they are known to be significantly out of adjustment or unless repairs have been made in the circuit. In these cases, set the particular controls to midrange.

Readjust the indicator oscilloscope Intensity control as needed during the procedure to provide an adequate display that is not excessively bright. This is especially important when a stationary spot or very slow trace is being displayed. A stationary spot can damage the crt screen if the intensity is too great.

An initial test equipment setup picture is shown for each major group of adjustments and checks. Beneath each setup picture is a complete list of front-panel control settings of the Type 1S1, plus significant control settings of other instruments. Any control that has been changed from the setting at the end of the previous step is given in bold-face type. Throughout the procedure, except where noted otherwise, the TIME/CM (MAGNIFIER) knob is locked to the TIME POSITION RANGE switch.

### Preliminary Procedure

1. Remove the left side panel of the indicator oscilloscope.
2. Connect the power cord of the indicator oscilloscope to the output of the autotransformer.
3. Place the Type 1S1 upside-down in front of the indicator oscilloscope.
4. Connect the interconnecting plug of the Type 1S1 to the indicator oscilloscope through the 30-inch flexible extension cable (see Fig. 5-3).
5. Connect the autotransformer and the other test instruments to the power line.

## Calibration—Type 151

6. Turn on the autotransformer, the indicator oscilloscope and the other instruments (not the tunnel diode pulse generator).

7. Set the autotransformer output to the normal line voltage of the indicator oscilloscope (e.g. 117 volts).

8. Allow at least 20 minutes for the Type 151 to warm up before making any calibration checks or adjustments.

9. Connect the 1X test probe to the vertical input connector of the test oscilloscope.

10. After 20 minutes warm up, check the dc balance of the test oscilloscope.

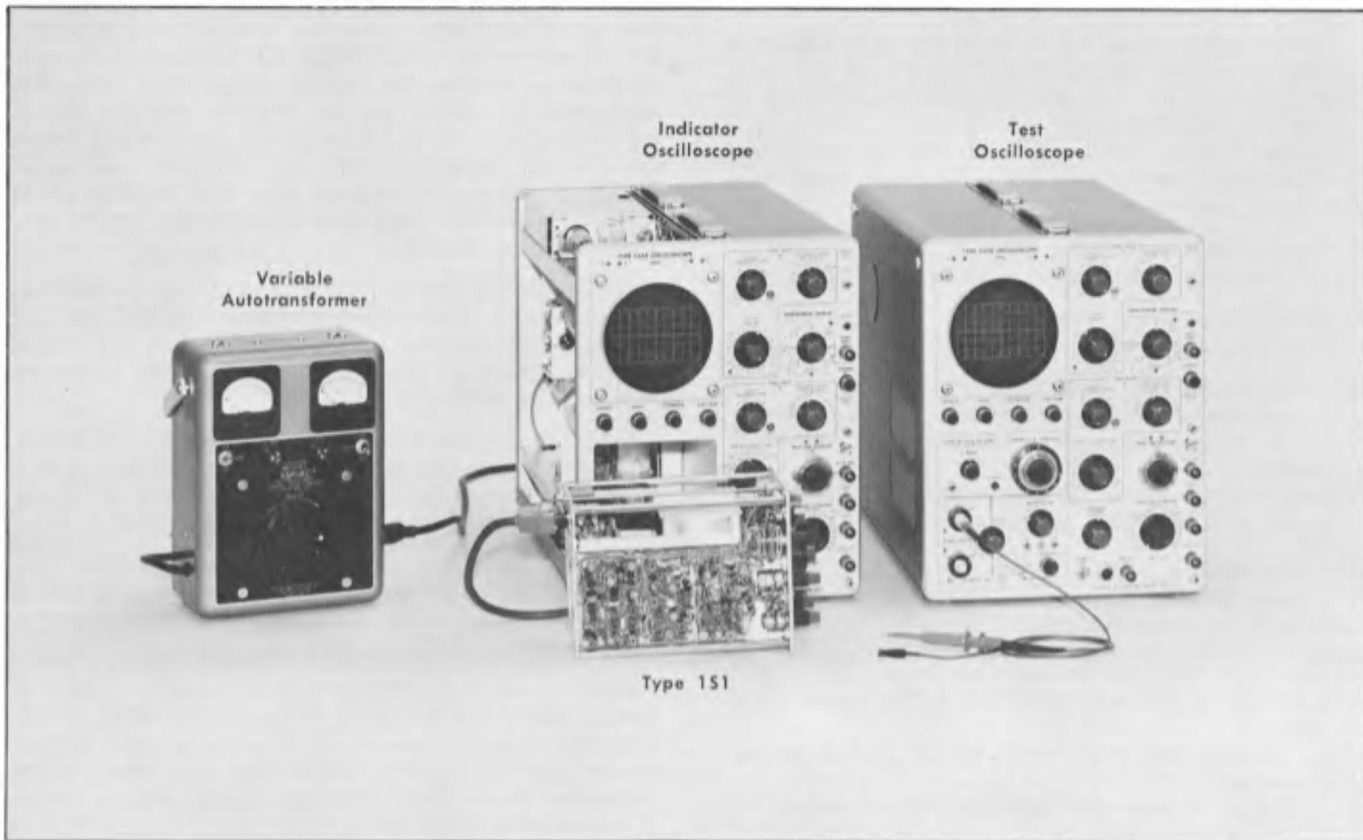

Fig. 5-3. Initial test setup for steps 1 through 3.

Type 151	
mVOLTS/CM	200
mVolts/Cm VARIABLE	CAL (at detent)
VERT POSITION	Centered
DC OFFSET $\pm 1$ V	At center of 10-turn range
TIME POSITION	Centered
FINE	Centered
SMOOTHING	NORM (clockwise)
SAMPLES/CM	Centered
DISPLAY MODE	NORMAL
MANUAL SCAN	
EXT HORIZ ATTEN	Clockwise
TIME/CM	5 nSEC
Time/Cm VARIABLE	CAL (at detent)
TRIGGER SOURCE	INT +
TRIGGER SENSITIVITY	Counterclockwise
RECOVERY TIME	Centered

Indicator Oscilloscope	
Stability (both time bases)	Counterclockwise (not Preset) <sup>1</sup>
Horizontal Display	Ext X1 or Ext X10
Intensity	Counterclockwise
Amplitude Calibrator	Off
Crt Cathode Selector	Chopped Blanking

Test Oscilloscope	
Horizontal Display	A
Time Base A Controls;	
Trigger Slope	Line +
Triggering Mode	Ac
Stability	Clockwise <sup>2</sup>
Triggering Level	Clockwise
Time/Cm	5 mSEC

<sup>1</sup>Turns off sweep. If oscilloscope without front-panel Stability control is used, turn sweep off by setting it for single sweep operation.

<sup>2</sup>Free runs sweep. If oscilloscope without front-panel Stability control is used, set triggering controls for a free-running sweep.

Time/Cm Variable	Calibrated (at detent)
Time Base B Stability	Counterclockwise (not Preset) <sup>1</sup>
Amplitude Calibrator	Off
Display	A—Vc
Millivolts/Cm	50
Input Atten	10
Millivolts/Cm Variable	Calib (at detent)
Vc Range	0.
Comparison Voltage	1.900
Input Coupling (Channel A)	Gnd
Input Coupling (Channel B)	Gnd

<sup>1</sup>Turns off sweep. If oscilloscope without front-panel Stability control is used, turn sweep off by setting it for single sweep operation.

## POWER SUPPLIES

### 1. Adjust Regulated Voltages

- Initial test equipment setup is shown in Fig. 5-3.
- Position the free-running test oscilloscope trace at the horizontal centerline for a zero-volt reference level.
- Set the test oscilloscope Input Coupling switch to Dc.
- Touch the tip of the 1X test probe to the -19-volt test point [see Fig. 5-4].
- Set the Vc Range switch to -11.
- Check that the trace is now within 1 cm of the test oscilloscope horizontal centerline, representing a reading of -19 volts  $\pm 0.5$  volts.
- Adjust R658 (-19 V CAL) if the reading is not correct.
- Touch the probe tip to the +19-volt test point (see Fig. 5-4).
- Set the Vc Range switch to +11.
- Check that the trace is now within 1 cm of the test oscilloscope horizontal centerline, representing a reading of +19 volts  $\pm 0.5$  volts.
- Adjust R625 (+19 V CAL) if the reading is not correct.

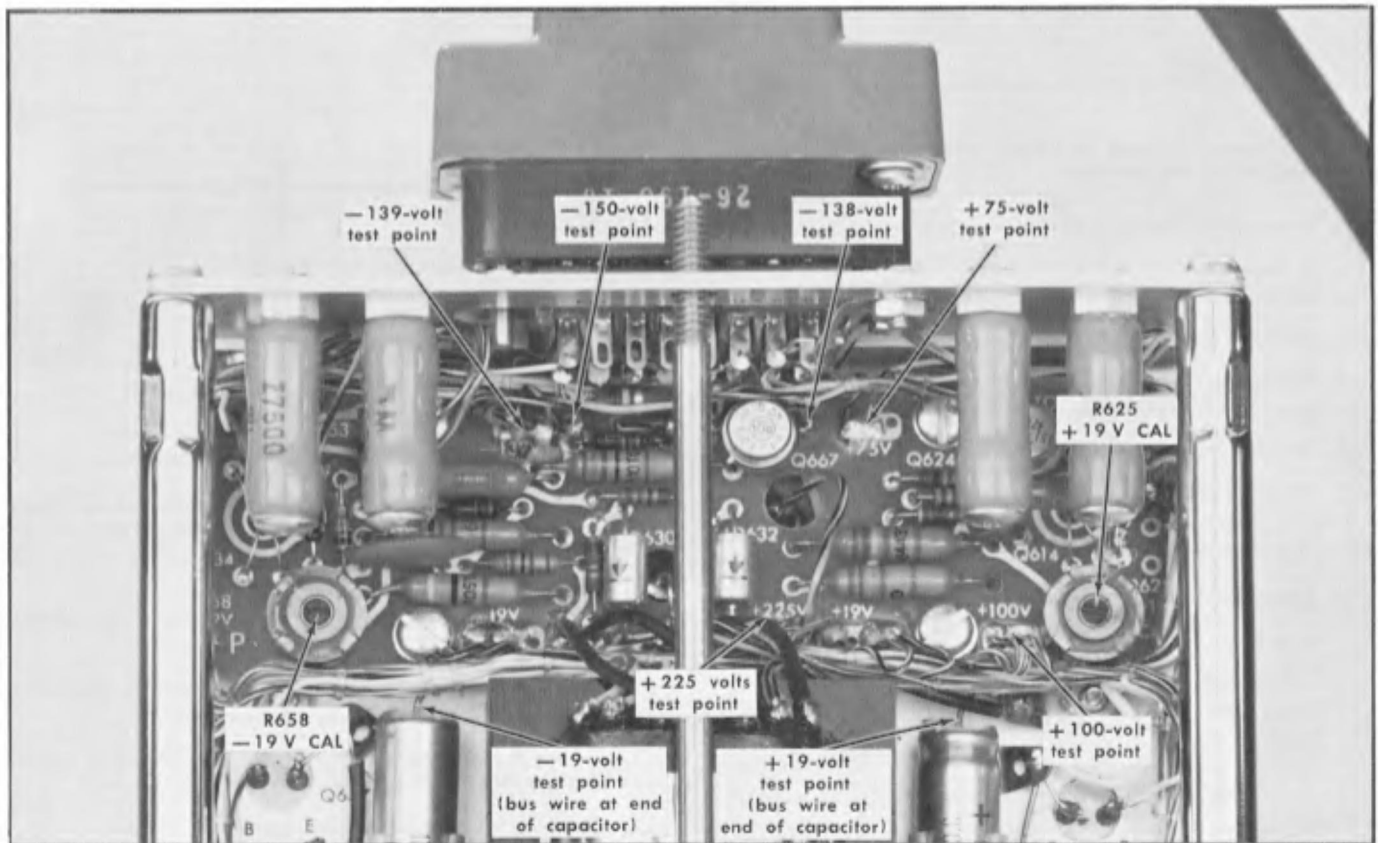

Fig. 5-4. Voltage test points and adjustment controls on bottom side of Type 151.



## 2. Check Probe Power

a. Load the PROBE POWER filament circuit either by connecting a cathode-follower probe to the PROBE POWER connector, or by connecting a 70-ohm 5-watt resistor from pin B of the connector to ground (pin A or C). See Fig. 5-5 for the PROBE POWER connector lettering. If the resistor is used to load the circuit, turn off the indicator oscilloscope power momentarily while installing the resistor.

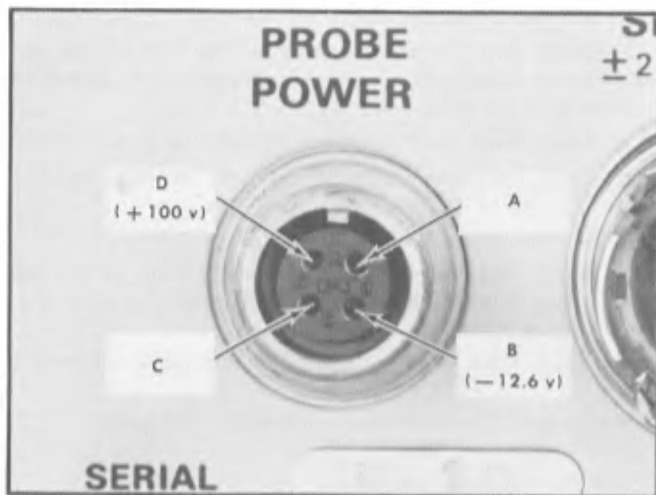

Fig. 5-5. Terminal lettering of PROBE POWER connector as seen from the front of the instrument.

b. Reset the following test oscilloscope controls:

Vc Range	0
Comparison Voltage	1.260

c. Recheck the zero-volt dc reference level.

d. Touch the 1X test probe to pin B of the PROBE POWER connector. (Be careful not to short the pin to chassis ground.)

e. Set the Vc Range switch to -11.

f. Check that the test oscilloscope trace is now within 1.2 cm of the horizontal centerline, representing a reading of -12.6 volts  $\pm 0.6$  volts.

g. Reset the following test oscilloscope controls:

Vc Range	0
Comparison Voltage	1.000
Input Atten	100
Millivolts/Cm	20

h. Touch the 1X test probe to pin D of the PROBE POWER connector.

i. Set the Vc Range switch to +11.

j. Check that the test oscilloscope trace is now within 1 cm of the horizontal centerline, representing a reading of +100 volts  $\pm 2$  volts. (This is a check of the test oscilloscope +100-volt supply.)

k. Disconnect the probe from the test point.

## 3. Check -19 V and +19 V Regulation

a. Reset the following test oscilloscope controls:

Vc Range	0
Input Coupling	Ac
Input Atten	1
Millivolts/Cm	10

b. Connect the tip of the 1X test probe to the -19-volt test point (see Fig. 5-4). Be sure to connect the test probe ground clip to chassis ground.

c. Trigger the test oscilloscope and observe the ripple display.

d. Vary the autotransformer output over the regulated voltage range of the indicator oscilloscope (e.g. 105 volts to 125 volts).

e. Check the display for less than 1 cm (10 mv) of ripple on the Type 1S1 -19-volt regulated supply (see Fig. 5-6).

f. Remove the cathode follower probe (or loading resistor) from the Type 1S1 PROBE POWER connector.

g. Recheck regulation of the -19-volt supply (with the probe power load removed) as described in steps d and e.

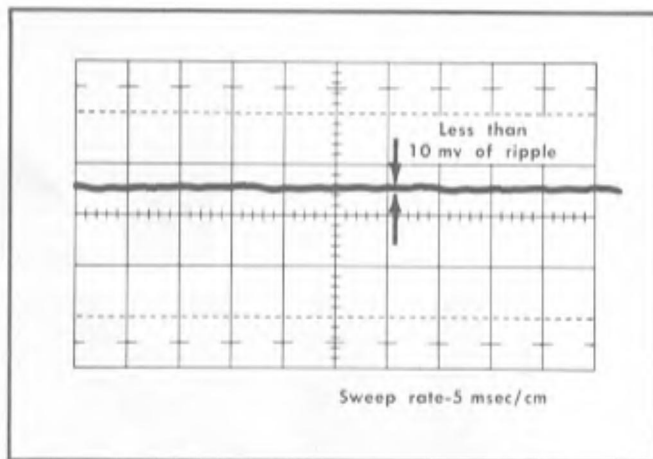

Fig. 5-6. Typical test oscilloscope display of power supply ripple at -19-volt or +19-volt test point (with trigger circuit not free running).

h. Connect the tip of the test probe to the +19-volt test point (see Fig. 5-4).

i. Vary the autotransformer output over the regulated voltage range of the indicator oscilloscope.

j. Check the display for less than 1 cm (10 mv) of ripple on the Type 1S1 +19-volt regulated supply.

k. Remove the probe from the test point.

l. Disconnect the 1X probe from the test oscilloscope input.

m. Disconnect the autotransformer and connect the indicator oscilloscope directly to the power line if the line voltage is near the nominal line voltage of the indicator oscilloscope (e.g. 117 volts). If not, reset the autotransformer to the design-center line voltage of the oscilloscope.





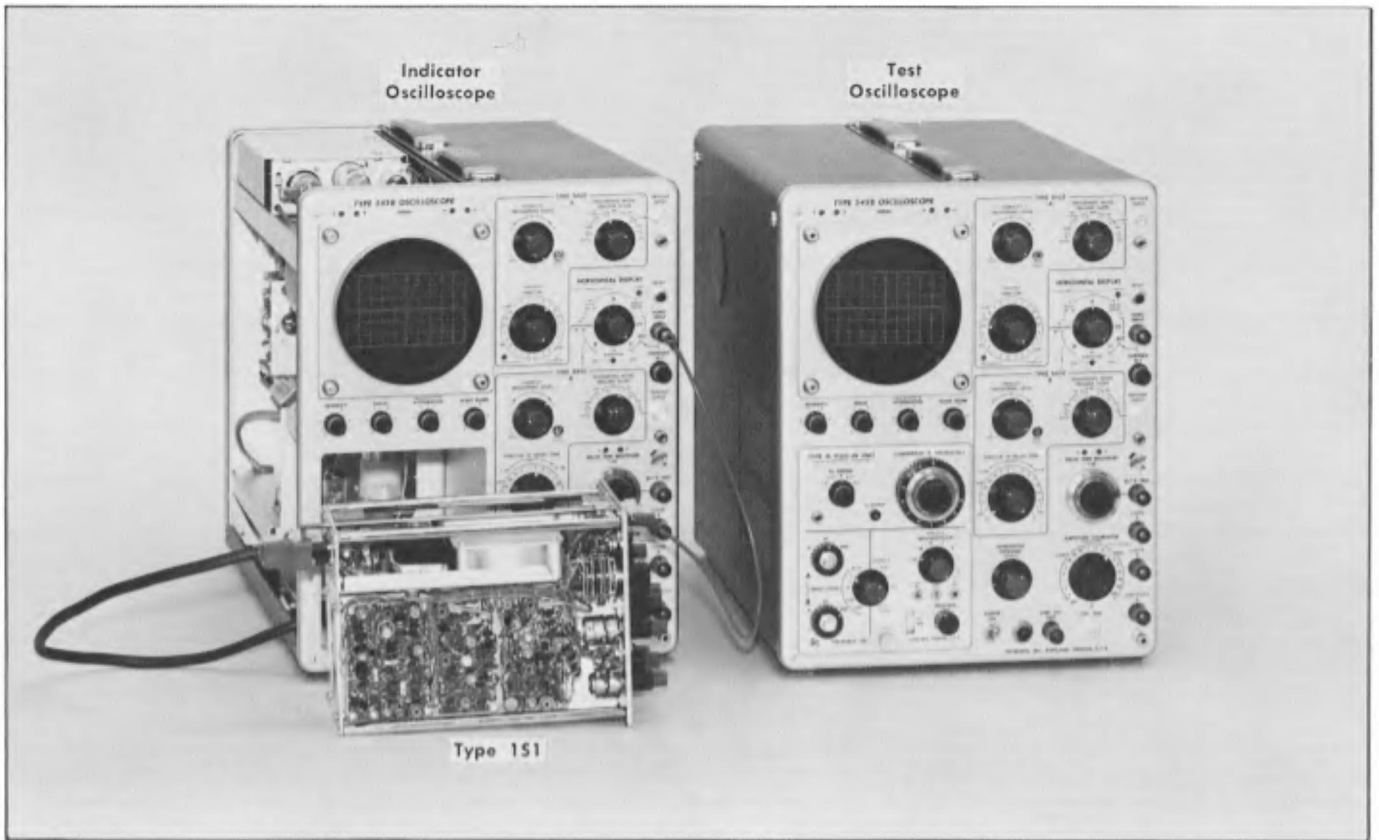

Fig. 5-7. Initial test setup for steps 4 through 7.

**Type 151**

mVOLTS/CM	200
mVolts/Cm VARIABLE	CAL
VERT POSITION	Centered
DC OFFSET	Centered
TIME POSITION	Centered
FINE	Centered
SMOOTHING	NORM (Clockwise)
SAMPLES/CM	Centered
DISPLAY MODE	NORMAL
MANUAL SCAN EXT HORIZ ATTEN	Clockwise
TIME/CM	5 nSEC
Time/Cm VARIABLE	CAL
TRIGGER SOURCE	INT +
<b>TRIGGER SENSITIVITY</b>	<b>Clockwise</b>
<b>RECOVERY TIME</b>	<b>SYNC</b>

**Indicator Oscilloscope**

Stability (both time bases)	Counterclockwise (not Preset)
Horizontal Display	Ext X1 or Ext X10
Intensity	Counterclockwise
Amplitude Calibrator	Off
Crt Cathode Selector	Chopped Blanking

**Test Oscilloscope**

Horizontal Display	A
Time Base A controls:	
<b>Trigger Slope</b>	<b>Int +</b>
Triggering Mode	Ac
<b>Stability</b>	<b>Clockwise</b>
<b>Triggering Level</b>	<b>Clockwise</b>
<b>Time/Cm</b>	<b>.5 mSEC</b>
Time/Cm Variable	Calibrated (at detent)
Time Base B Stability	Counterclockwise (not Preset)

Amplitude Calibrator	Off
Display	A—Vc
<b>Millivolts/Cm</b>	<b>50</b>
<b>Input Atten</b>	<b>10</b>
Millivolts/Cm Variable	Calib (at detent)
<b>Vc Range</b>	<b>0</b>
<b>Comparison Voltage</b>	<b>1.900</b>
<b>Input Coupling (Channel A)</b>	<b>Dc</b>
Input Coupling (Channel B)	Gnd

### TRIGGER CIRCUIT

#### 4. Adjust Internal Trigger Level

- a. Test equipment setup is shown in Fig. 5-7.
- b. Leave the Type 1S1 turned upside down.
- c. Connect a patch cord from the Type 1S1 HORIZ OUTPUT jack to the Ext Horiz Input jack of the indicator oscilloscope.
- d. Adjust the indicator oscilloscope Intensity control to present the free-running sampling display. If there is no trace, use the oscilloscope Horizontal position control to position the trace on the screen.
- e. Adjust the Type 1S1 DC OFFSET control to vertically position the trace to the center of the crt screen. (Each dot will have a slight "tail" on it due to the unshielded leads in the extension cable.)
- f. Adjust the indicator oscilloscope Ext Horiz Input Variable control and Horizontal Position control to obtain approximately 10.2 cm of horizontal deflection (see Fig. 5-8). Use the Horizontal Display switch position (Ext X1 or Ext X10) that will permit this adjustment.
- g. Slowly turn the Type 1S1 TRIGGER SENSITIVITY control counterclockwise.

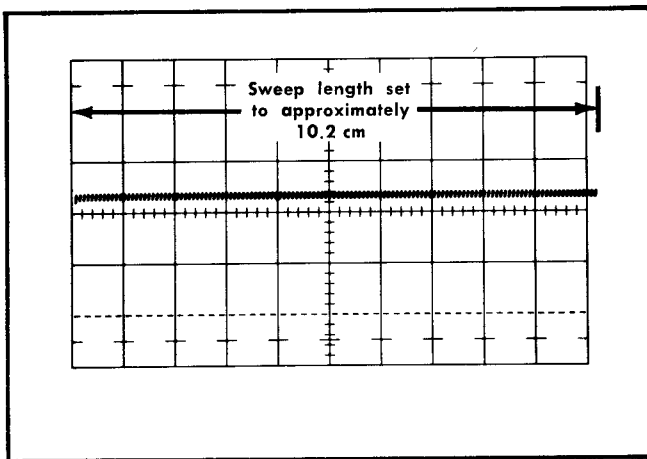

Fig. 5-8. Typical crt display after adjusting indicator oscilloscope Horiz Input Variable control.

h. Check that the trace stops free running as the control is turned counterclockwise through a position approximately 45° clockwise from top center, and that the trace begins to free run as the control is turned clockwise through that position.

i. Adjust R420 (INT TRIG LEVEL) if the operation is not correct. See Fig. 5-10 for the location of R420.

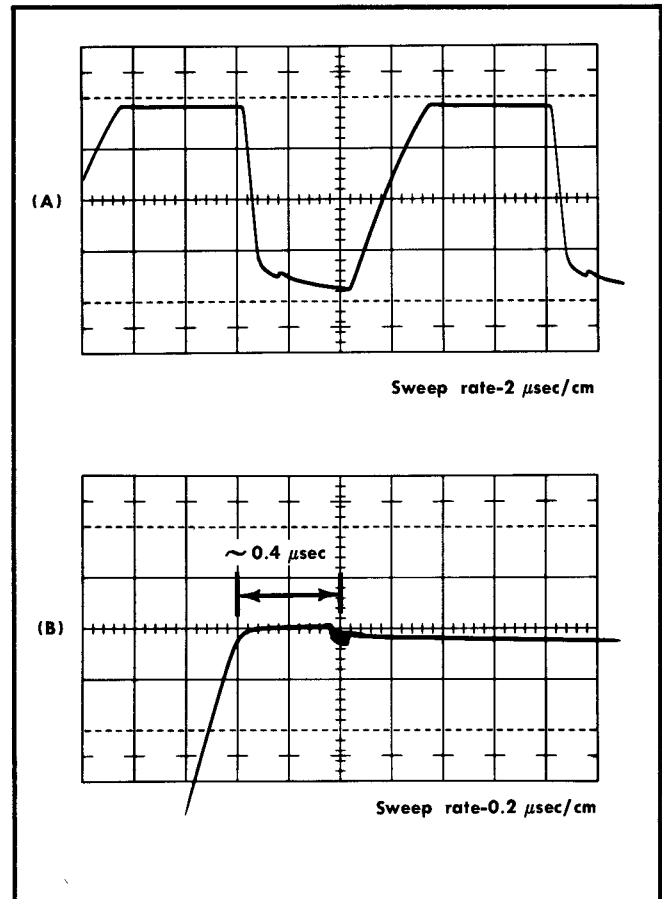

Fig. 5-9. Typical test oscilloscope displays for checking adjustment of R460 (CONTROL TD BIAS).

#### 5. Adjust Control TD Bias

- a. Turn the Type 1S1 TRIGGER SENSITIVITY control fully clockwise.
- b. Install the 10X probe on the test oscilloscope vertical input.
- c. Check compensation of the test probe.
- d. Connect the test probe to the junction of R458 and D462 (see Fig. 5-10).
- e. Set the test oscilloscope Time/Cm switch to 2 μSec.
- f. Trigger the test oscilloscope display to obtain a display similar to that shown in Fig. 5-9A.

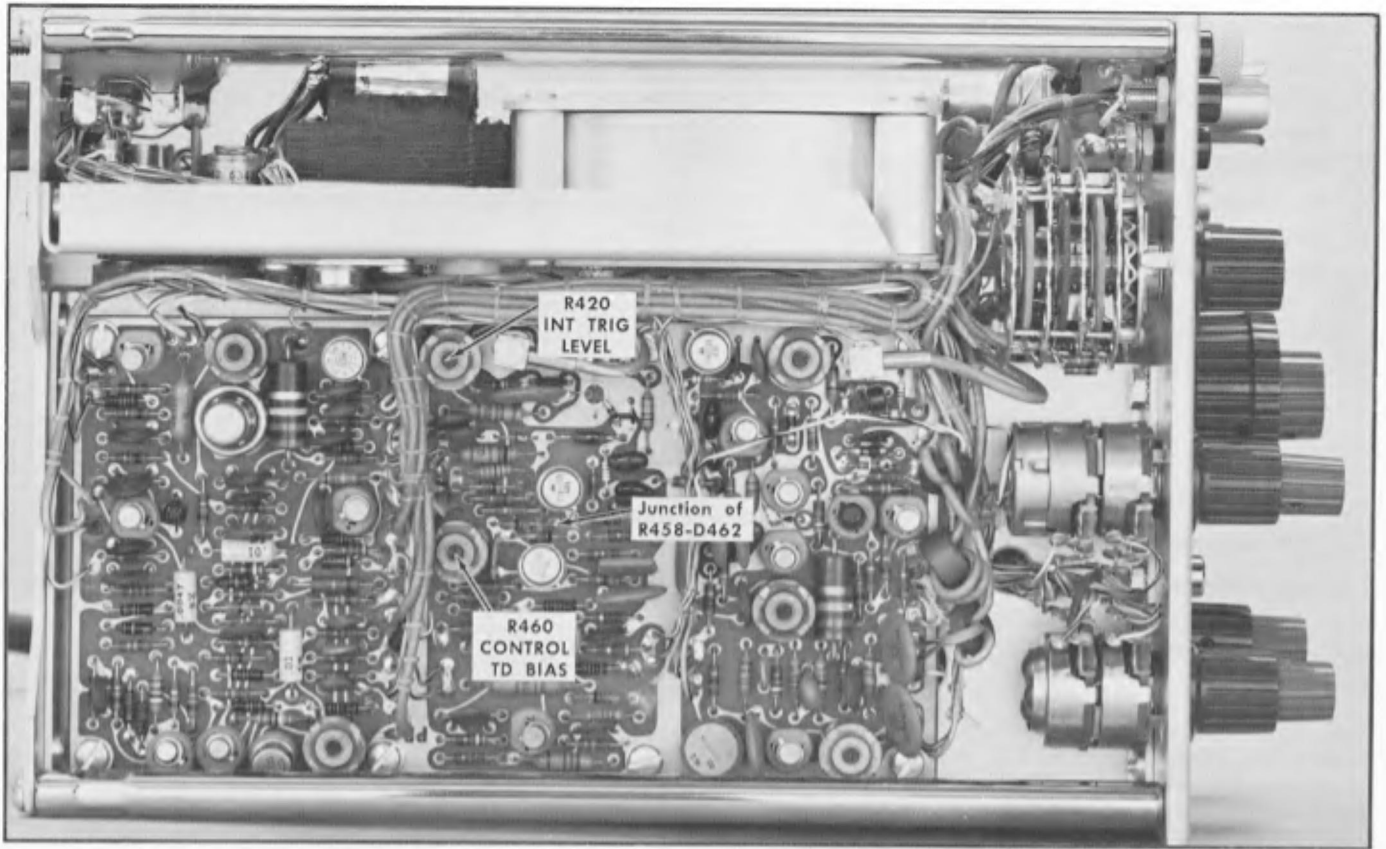

Fig. 5-10. Trigger circuit adjustments on right side of Type 151. (Unit is positioned upside-down on test bench.)

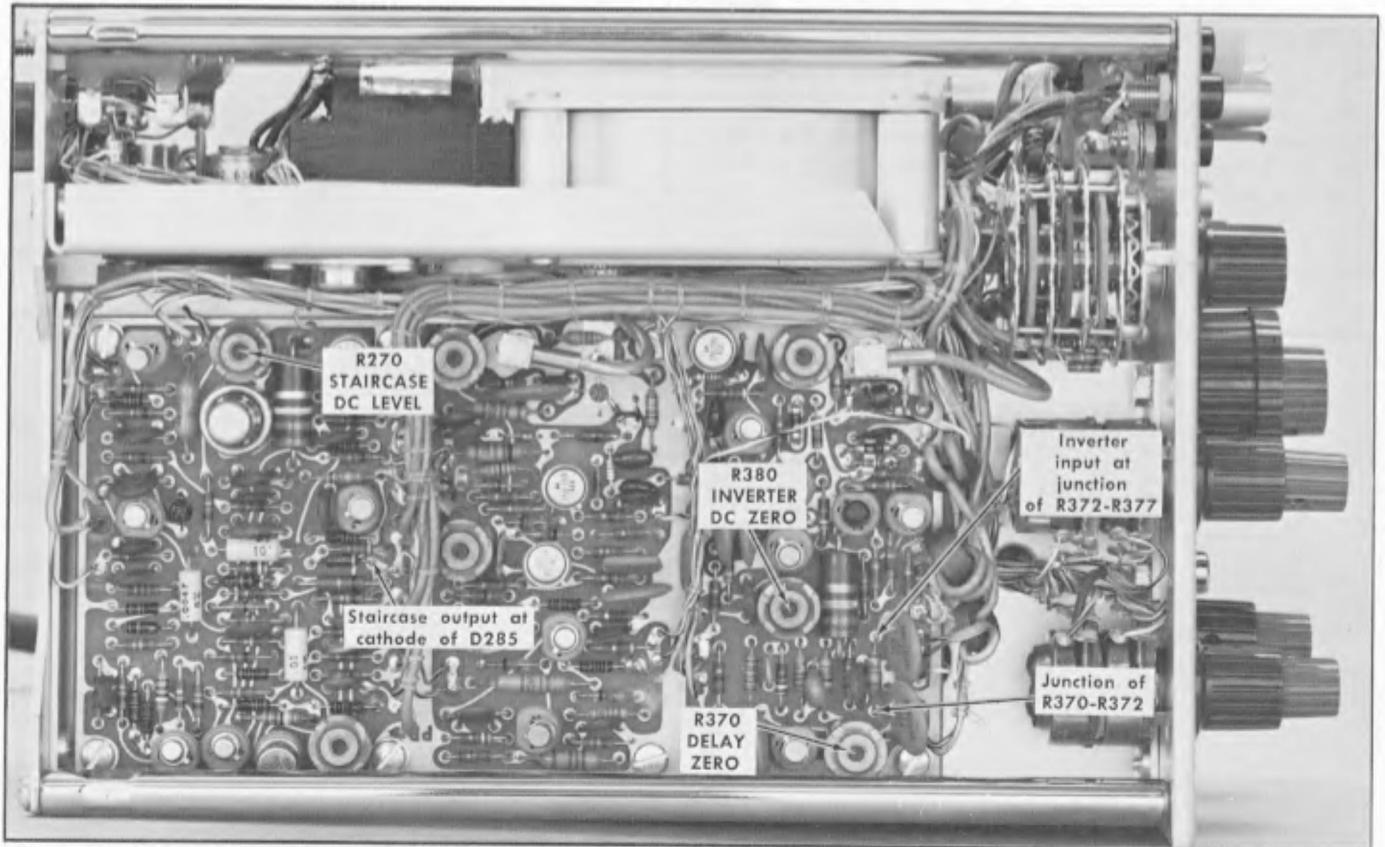

Fig. 5-11. Staircase and inverter adjustments on right side of Type 151. (Unit is positioned upside-down on test bench.)

g. Reset the following test oscilloscope controls:

Time/Cm	.2 $\mu$ Sec
Millivolts/Cm	20
Input Atten	1
Vc Range	+11

h. Check for a leading corner on the waveform similar to that shown in Fig. 5-9B. Duration of the indicated portion of the waveform should be about 0.4  $\mu$ sec (2 cm).

i. Adjust R460 (CONTROL TD BIAS) if the display is not as indicated. See Fig. 5-10 for the location of R460.

j. Switch the RECOVERY TIME control out of SYNC position and set it to midrange.

k. Remove the probe from the test point.

## STAIRCASE AND FAST RAMP ADJUSTMENTS

### 6. Adjust Staircase DC Level

a. Reset the following Type 1S1 controls:

DISPLAY MODE	SINGLE SWEEP
TIME POSITION	Clockwise
FINE	Clockwise
SAMPLES/CM	MIN (Clockwise)
TIME/CM	5 $\mu$ SEC

b. Reset the following test oscilloscope controls:

Vc Range	0
Millivolts/Cm	10
Input Coupling	Gnd
Time/Cm	0.2 mSec

c. Connect the test probe to the staircase output at the cathode of D285 (see Fig. 5-11).

d. Free run the test oscilloscope trace and position it for a zero-volt dc reference level.

e. Set the test oscilloscope Input Coupling switch to Dc.

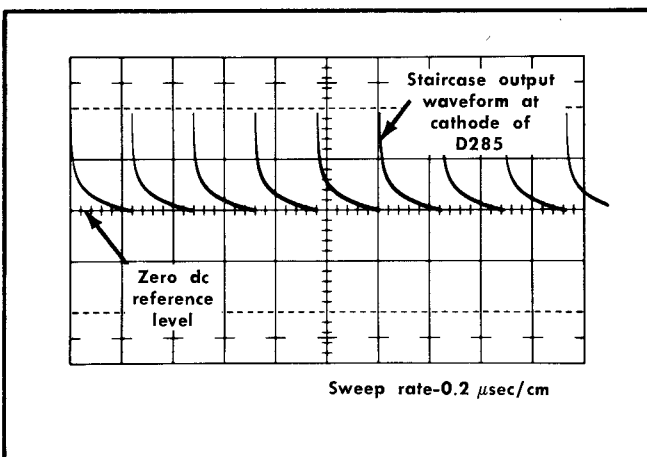

Fig. 5-12. Typical test oscilloscope display for checking adjustment of R270 (STAIRCASE DC LEVEL).

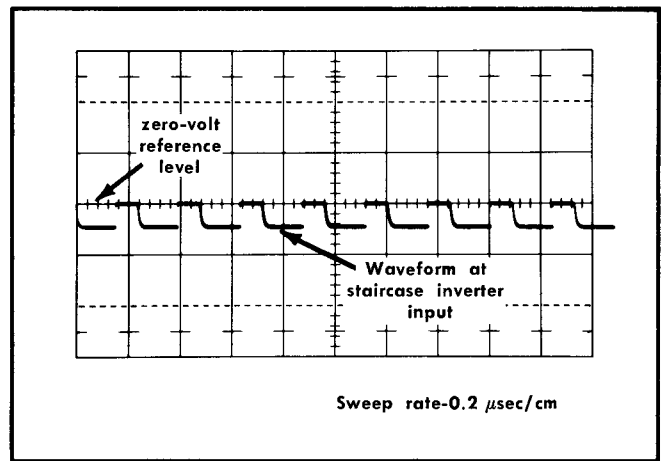

Fig. 5-13. Typical test oscilloscope display for checking adjustment of R380 (INVERTER DC ZERO).

f. Trigger the test oscilloscope.

g. Check for a dc level of zero volts at the bottom of the main portion of the waveform (see Fig. 5-12).

h. Adjust R270 (STAIRCASE DC LEVEL) if the display is not correct. See Fig. 5-11 for the location of R270.

i. Disconnect the probe from the test point.

### 7. Adjust Inverter DC Zero

a. Set the test oscilloscope Input Coupling switch to Gnd.

b. Connect the test probe to the junction of R370 (DELAY ZERO) and R372 (see Fig. 5-11).

c. Free run the test oscilloscope trace and reset the zero dc reference level.

d. Set the Input Coupling switch to Dc.

e. Adjust R370 to position the free-running trace to the horizontal centerline of the test oscilloscope. See Fig. 5-11 for the location of R370.

f. Move the test probe tip to the staircase inverter input, located at the junction of R372 and R377 (see Fig. 5-11). This is at the other end of the same resistor.

g. Trigger the test oscilloscope display.

h. Check for a dc level of zero volts at the top of the displayed waveform (see Fig. 5-13).

i. Adjust R380 (INVERTER DC ZERO) if the level is not correct. See Fig. 5-11 for the location of R380.

j. Disconnect the test probe. (If this step is performed out of sequence, be sure to reset the DELAY ZERO adjustment as given in step 11.)

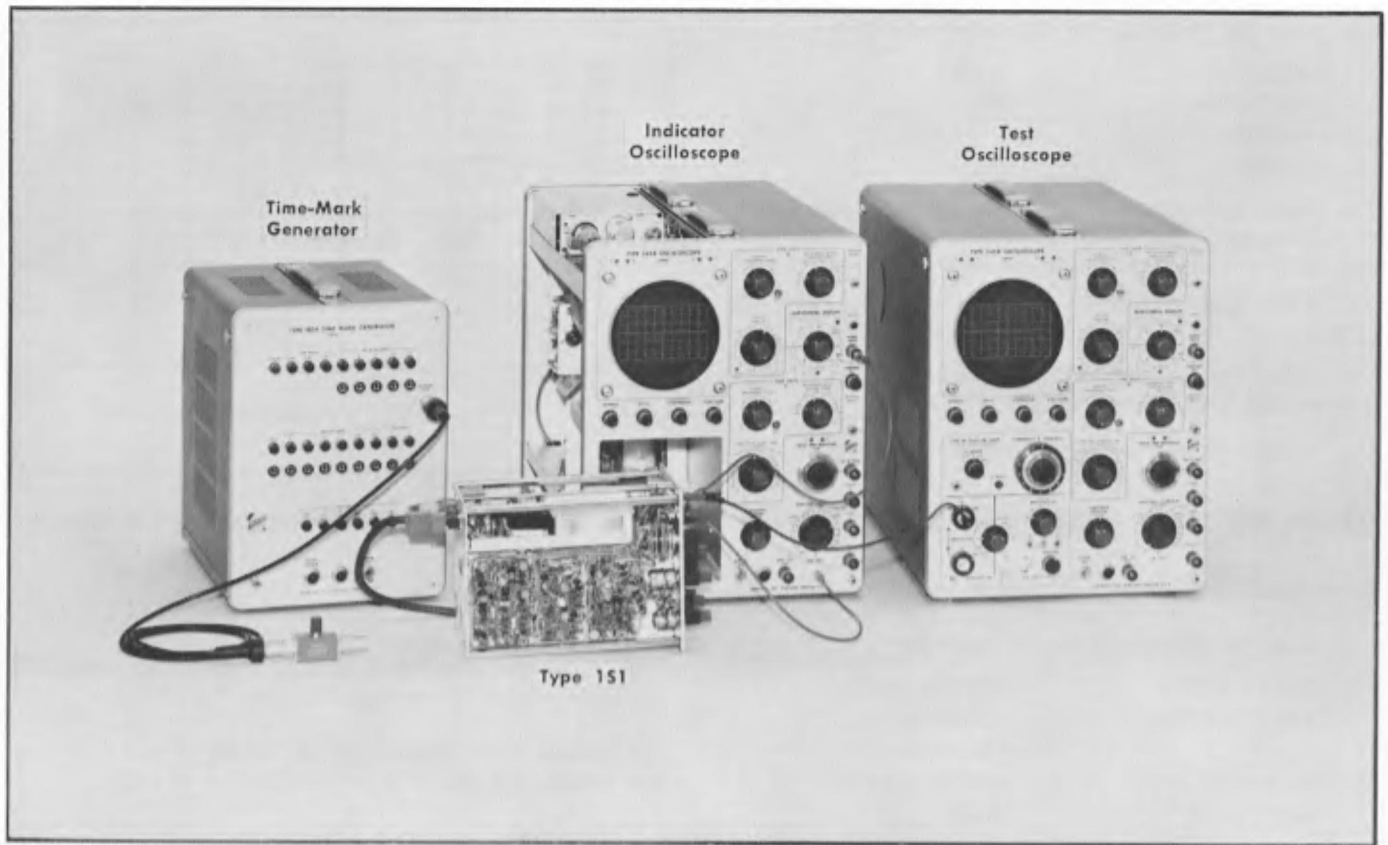

Fig. 5-14. Initial test equipment setup for steps 8 through 10.

**Type 151**

mVOLTS/CM	200
mVolts/Cm VARIABLE	CAL
VERT POSITION	Centered
DC OFFSET	Centered
<b>TIME POSITION</b>	<b>Centered</b>
<b>FINE</b>	<b>Centered</b>
SMOOTHING	NORM (Clockwise)
<b>SAMPLES/CM</b>	<b>Centered</b>
<b>DISPLAY MODE</b>	<b>EXT HORIZ</b>
<b>MANUAL SCAN</b>	
EXT HORIZ ATTEN	Counterclockwise
<b>TIME/CM</b>	<b>.5 μSEC</b>
Time/Cm VARIABLE	CAL
<b>TRIGGER SOURCE</b>	<b>FREE RUN</b>
TRIGGER SENSITIVITY	Clockwise
RECOVERY TIME	Centered

**Indicator Oscilloscope**

Stability (both time bases)	Counterclockwise (not Preset)
Horizontal Display	Ext Horiz Input
Intensity	Normal brightness of dot
<b>Amplitude Calibrator</b>	<b>10 Volts</b>
Crt Cathode Selector	Chopped Blanking

**Test Oscilloscope**

Horizontal Display	A
Time Base A controls:	
Trigger Slope	Int +
Triggering Mode	Ac
<b>Stability</b>	<b>Clockwise</b>
<b>Triggering Level</b>	<b>Clockwise</b>
<b>Time/Cm</b>	<b>.5 mSec</b>
Time/Cm Variable	Calibrated (at detent)
Time Base B Stability	Counterclockwise (not Preset)

Amplitude Calibrator	Off
Display	A—Vc
Millivolts/Cm	50
Input Atten	R = ∞
Millivolts/Cm Variable	Counterclockwise
Vc Range	—11
Comparison Voltage	4.000
Input Coupling (Channel A)	Dc
Input Coupling (Channel B)	Gnd

### 8. Adjust Timing Cal

Before checking the timing of the Type 1S1, the indicator oscilloscope external horizontal deflection factor must be set to 1 volt/cm  $\pm 1\%$ . Any accurate voltage source ( $\pm 0.5\%$ ), either a signal or a dc voltage, may be used for setting this adjustment. In the following procedure, the differential comparator test oscilloscope is used to monitor a calibrator signal applied through the Type 1S1 external horizontal circuitry to the external horizontal deflection system of the indicator oscilloscope.

- a. Test equipment setup is shown in Fig. 5-14.
- b. Disconnect the probe from the test oscilloscope vertical input.
- c. Connect a BNC/banana patch cord from the Type 1S1 HORIZ OUTPUT jack to the test oscilloscope vertical input connector. The patch cord from the HORIZ OUTPUT jack to the indicator oscilloscope Ext Horiz Input jack should remain in place (see Fig. 5-14).
- d. Connect a BNC/banana patch cord from the indicator oscilloscope Cal Out connector to the Type 1S1 EXT HORIZ INPUT jack.
- e. With the test oscilloscope vertical Position control, position the free-running trace at the horizontal centerline of the test oscilloscope crt screen.
- f. Adjust the indicator oscilloscope Horizontal Position control to position the displayed dot on the 1-cm graticule line of the indicator oscilloscope crt screen.
- g. Set the test oscilloscope Vc Range switch to +11.
- h. With the Type 1S1 EXT HORIZ ATTEN control, position the free-running trace or square-wave top to the horizontal centerline of the test oscilloscope screen.
- i. Trigger the test oscilloscope to obtain a display similar to that shown Fig. 5-15A.
- j. Set the test oscilloscope Vc Range switch back to —11 and check for a waveform similar to Fig. 5-15B. Readjust the test oscilloscope Position control and/or the Type 1S1 EXT HORIZ ATTEN control if the top and bottom of the calibrator waveform are not at the horizontal centerline of the test oscilloscope with the Vc Range switch at —11 and +11, respectively.

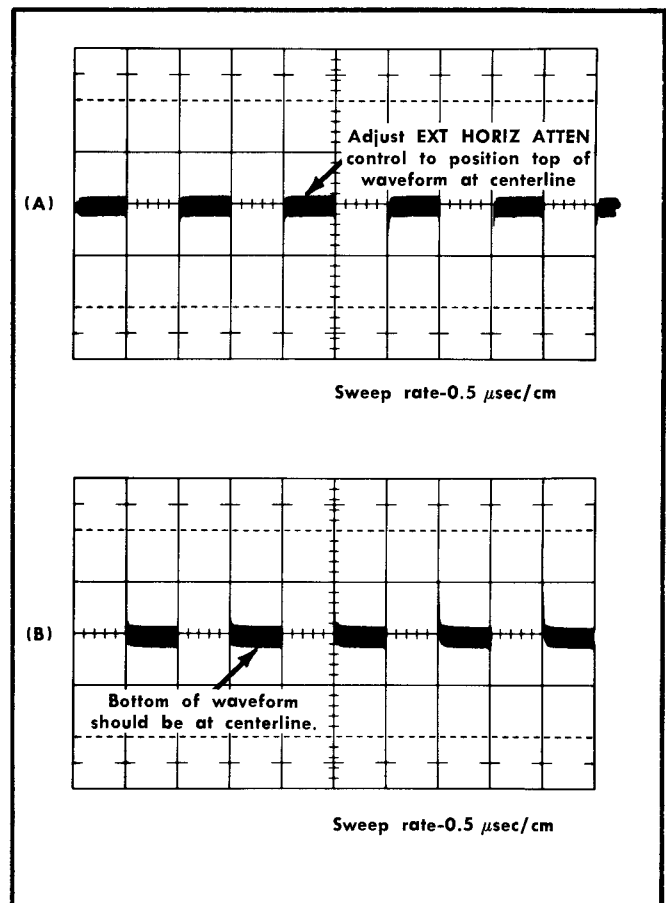

Fig. 5-15. Typical test oscilloscope displays for adjusting EXT HORIZ ATTEN control for 8.00 volts.

- k. Adjust the indicator oscilloscope Intensity control so that the displayed dots on the indicator oscilloscope crt screen are very dim, but visible.

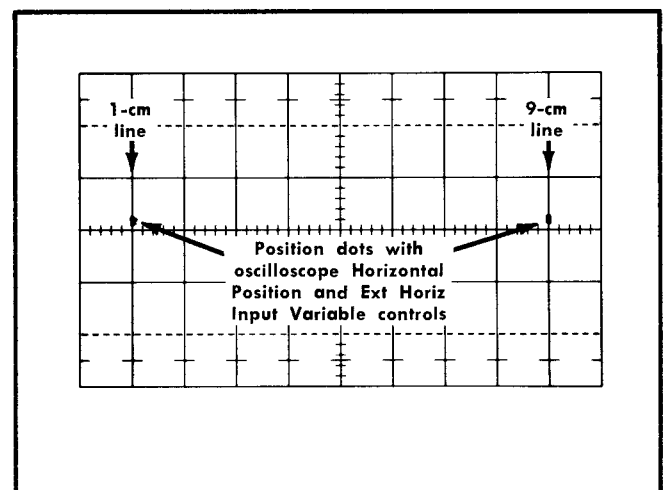

Fig. 5-16. Indicator oscilloscope display used for setting Ext Horiz Input Variable control.

## Calibration—Type 1S1

l. With the indicator oscilloscope Horizontal Position control and Ext Horiz Input Variable control, position the two dots to the 1-cm and 9-cm graticule lines as shown in Fig. 5-16. This sets the external horizontal deflection factor to 1 volt/cm. Now, do not change the setting of the Ext Horiz Input Variable control for the remainder of the calibration procedure, or at least until the Type 1S1 TIMING CAL adjustment has been checked.

m. Disconnect the patch cords that connect to the test oscilloscope vertical input and to the indicator oscilloscope Cal Out connector. Leave the patch cord connected between the Type 1S1 HORIZ OUTPUT jack and the indicator oscilloscope Ext Horiz Input jack.

n. Reset the test oscilloscope Input Atten switch to 1.

o. Connect the time-mark generator Marker Out signal through an adapter, a coax and the variable attenuator to the SIGNAL IN connector of the Type 1S1.

p. Set the time-mark generator for a 1- $\mu$ sec output signal.

q. Adjust the variable attenuator to produce approximately 2 cm of vertical deflection on the indicator oscilloscope crt screen. (Increase the indicator oscilloscope intensity if necessary.)

r. Reset the following Type 1S1 controls:

DISPLAY MODE	NORMAL
TRIGGER SOURCE	INT +

s. Trigger the display with the Type 1S1 TRIGGER SENSITIVITY control.

t. Adjust the indicator oscilloscope Horizontal Position control to position the start of the display to the left edge of the graticule (see Fig. 5-17A).

u. Adjust the Type 1S1 SAMPLES/CM control for an adequate display of the time-mark signal (see Fig. 5-17B). The dots in the baseline should be as close together as possible without reducing the display repetition rate far enough to cause it to flicker.

v. Set the time-mark generator for a 5- $\mu$ sec output signal.

w. Set the Type 1S1 TIME/CM switch to 5  $\mu$ SEC. The indicator oscilloscope Intensity control may require readjustment for this slower ramp.

x. Adjust the Time Position FINE control to position one of the 5- $\mu$ sec markers on the 1-cm graticule line (see Fig. 5-17C).

y. Check for correct timing (1 marker/cm) over the center 8 cm ( $\pm 0.08$  cm) of the graticule. See Fig. 5-17D.

z. Adjust R335 (TIMING CAL) if the timing is not correct. See Fig. 5-18 for the location of R335.

## 9. Adjust Comparator Level



a. Leave the time-mark signal connected to the SIGNAL IN connector.

b. Install the 10X probe on the vertical input of the test oscilloscope.

c. Reset the following test oscilloscope controls:

Time/Cm	.1 mSEC
Vc Range	0
Input Coupling	Ac
Millivolts/Cm	2
Millivolts/Cm Variable	Calib

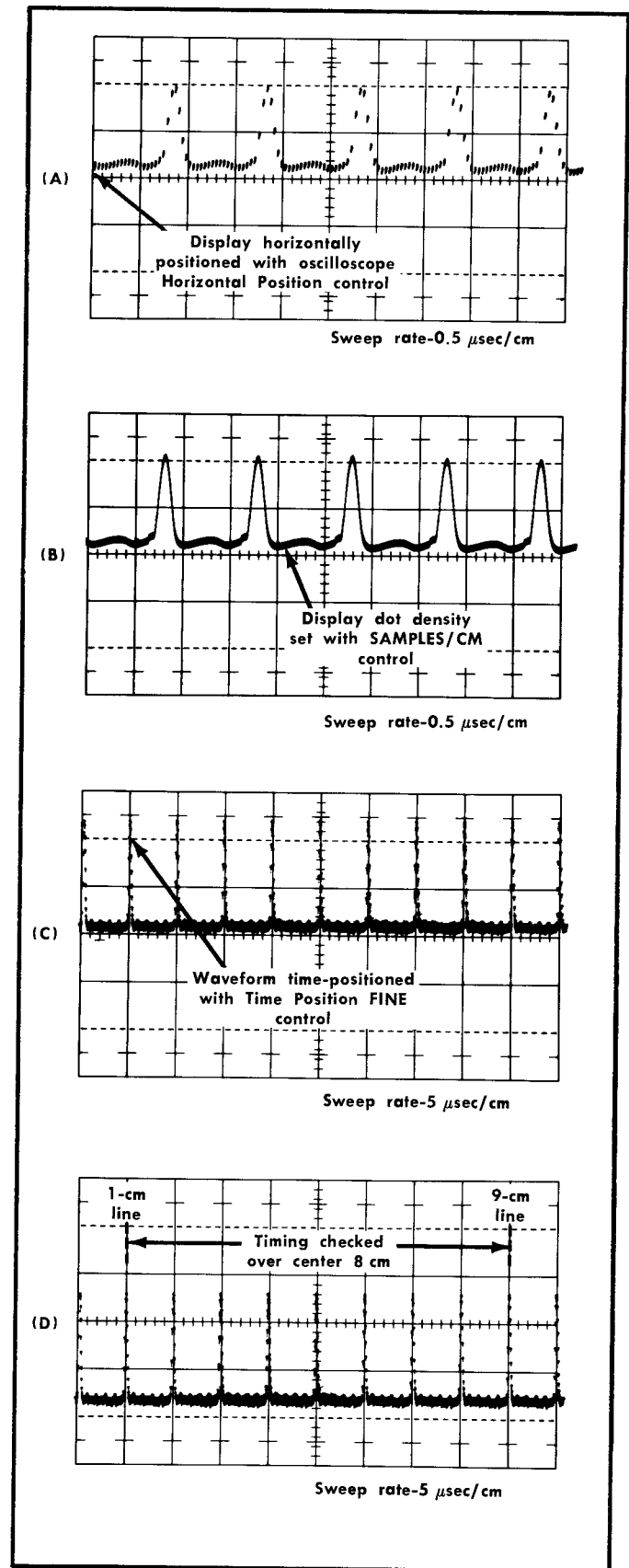

Fig. 5-17. Typical indicator oscilloscope displays for setting up sampling display and checking adjustment of R335 (TIMING CAL).



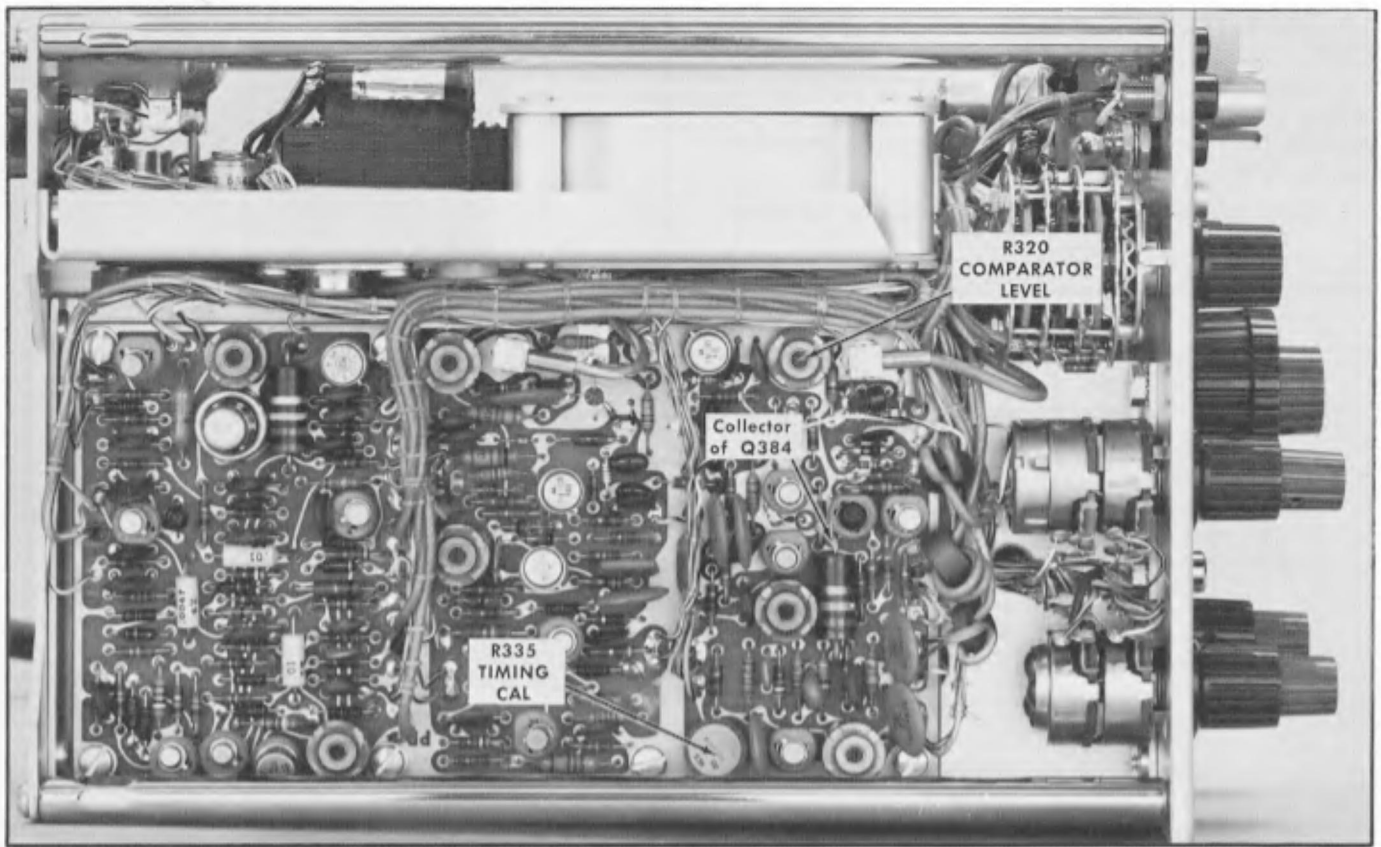

Fig. 5-18. Fast ramp and comparator adjustments on right side of Type 151 (unit is positioned upside-down on test bench).

d. Set the indicator oscilloscope Intensity control for a dim trace.

e. Reset the following Type 151 controls:

TIME/CM	50 $\mu$ SEC
DISPLAY MODE	MAN
TIME POSITION	Clockwise
FINE	Clockwise

f. Adjust the Type 151 MANUAL SCAN control to position the displayed spot about 0.5 cm from the left edge of the graticule.

g. Connect the test probe to the collector of Q384 (See Fig. 5-18).

h. Trigger the test oscilloscope display.

i. Check for a waveform similar to that shown in Fig. 5-19. The transition to the spike in the trailing edge of the waveform should be about 20 mv (1 cm) down from the top of the pulse.

j. Adjust R320 (COMPARATOR LEVEL) if the display is not as indicated. See Fig. 5-18 for the location of R320.

k. Remove the probe from the test point.

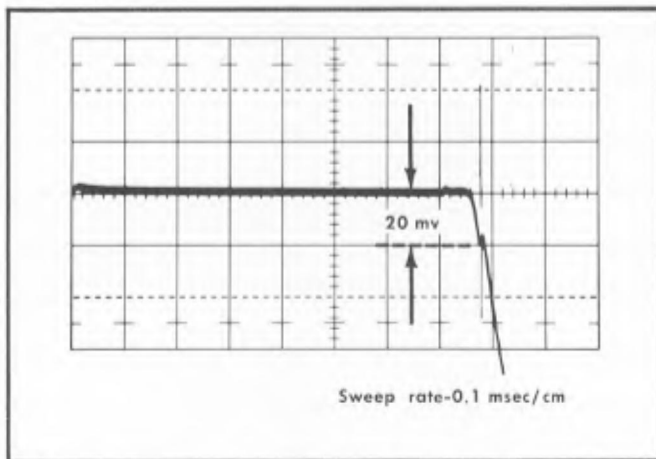

Fig. 5-19. Typical test oscilloscope display for checking adjustment of R320 (COMPARATOR LEVEL).

### 10. Adjust 50 nS Ramp Timing

a. Leave the time-mark generator connected to the Type 151 SIGNAL IN connector.

b. Set the generator for a 50-Mc output signal.

c. Reset the following Type 151 controls:

TIME/CM	5 nSEC
DISPLAY MODE	NORMAL
RECOVERY TIME	Counterclockwise (not SYNC)
TIME POSITION	Centered
FINE	Centered

d. Adjust the variable attenuator to produce approximately 4 cm of vertical deflection on the indicator oscilloscope crt screen.



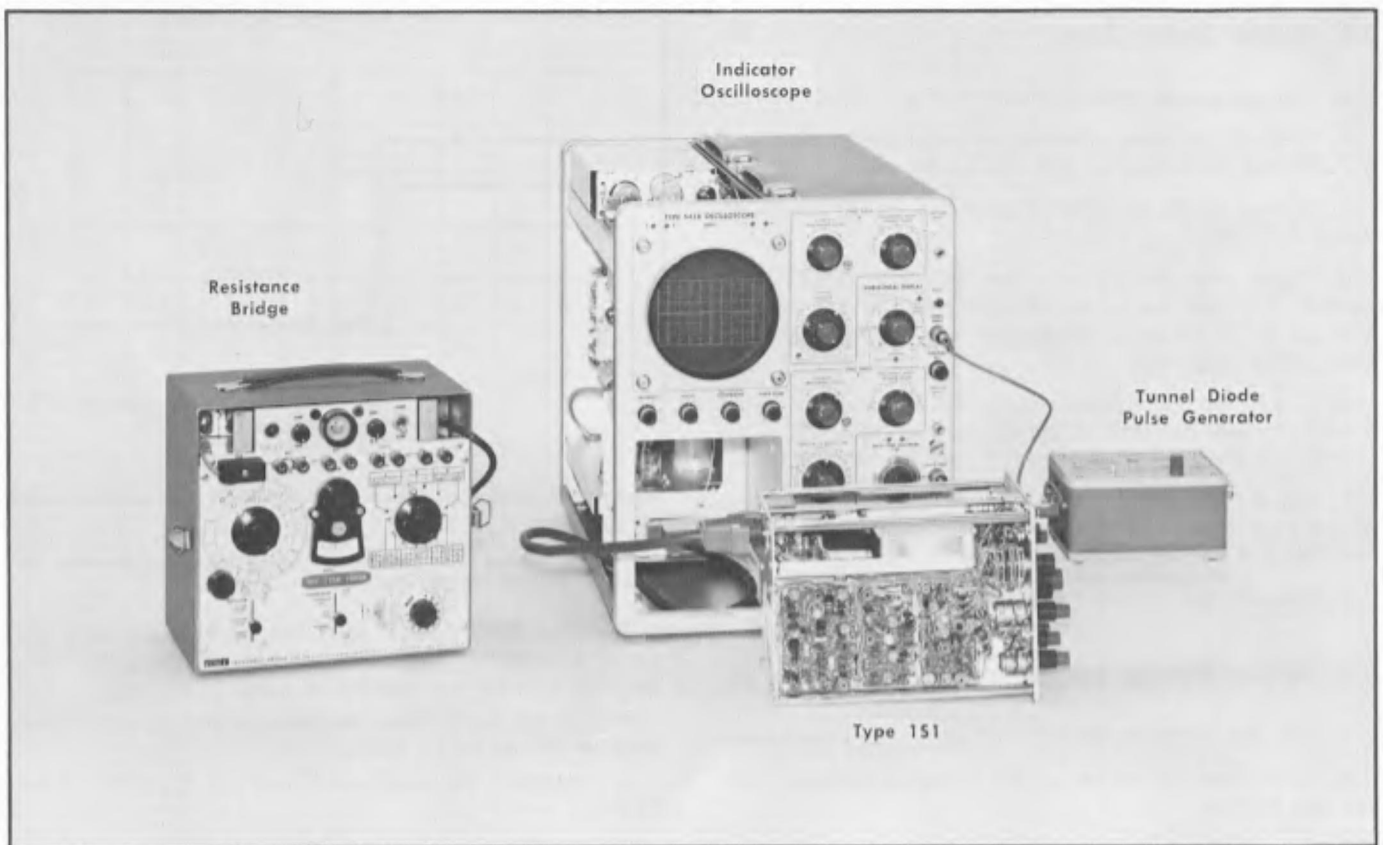

Fig. 5-22. Initial test equipment setup for steps 11 through 13.

	<b>Type 151</b>	<b>TIME/CM</b>	<b>10 nSEC</b>
mVOLTS/CM	200	Time/Cm VARIABLE	CAL
mVolts/Cm VARIABLE	CAL	<b>TRIGGER SOURCE</b>	<b>INT —</b>
VERT POSITION	Centered	<b>TRIGGER SENSITIVITY</b>	<b>Centered</b>
DC OFFSET	Centered	<b>RECOVERY TIME</b>	<b>Centered</b>
<b>TIME POSITION</b>	<b>Clockwise</b>		
<b>FINE</b>	<b>Clockwise</b>		
SMOOTHING	NORM (Clockwise)	<b>Indicator Oscilloscope</b>	
SAMPLES/CM	Normal display	Stability (both time bases)	Counterclockwise (not Preset)
DISPLAY MODE	NORMAL	Horizontal Display	Ext Horiz Input
<b>MANUAL SCAN</b>		Intensity	Normal brightness
<b>EXT HORIZ ATTEN</b>	<b>Clockwise</b>	<b>Amplitude Calibrator</b>	<b>Off</b>
		Crt Cathode Selector	Chopped Blanking

### 11. Adjust Delay Zero



- a. Test equipment setup is shown in Fig. 5-22.
- b. Connect the tunnel diode pulse generator to the Type 151 SIGNAL IN connector and turn on the generator.
- c. Pull out on the MAGNIFIER knob and set the TIME/CM switch to 1 nSEC.
- d. Trigger the display with the TRIGGER SENSITIVITY control. (For this check, the TRIGGER SENSITIVITY control must be set to the most counterclockwise position that provides stable triggering).
- e. Check that the negative-going pulse rise occurs from 3 to 6 cm after the start of the sweep (see Fig. 5-23). This control will be out of adjustment if step 7 was performed.
- f. Adjust R370 (DELAY ZERO) to position the pulse rise at the 4-cm graticule line if the display is not as indicated. See Fig. 5-24 for the location of R370.
- g. Turn off and remove the tunnel diode pulse generator.

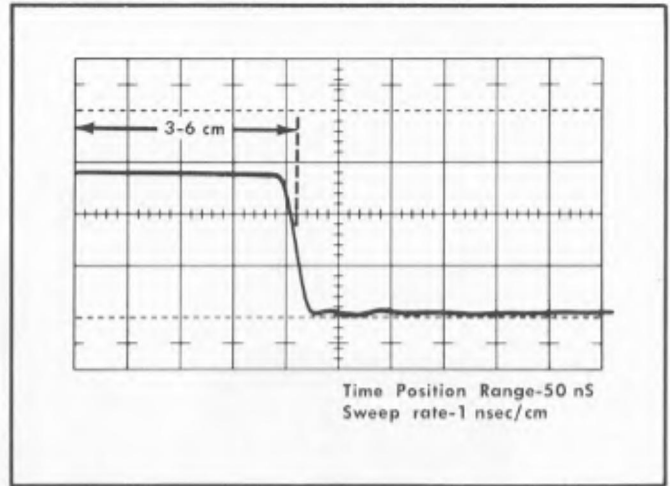

Fig. 5-23. Typical indicator oscilloscope display for checking adjustment of R370 (DELAY ZERO).

### 12. Adjust Sweep Length



- a. Turn the TRIGGER SENSITIVITY control fully clockwise.
- b. Check that the length of the sweep is between 10.0 cm and 10.3 cm.

- c. Adjust R290 (SWEEP LENGTH) for approximately 10.2 cm of trace if the length was not between the given limits. See Fig. 5-24 for the location of R290.
- d. Turn off the indicator oscilloscope and disconnect both ends of the extension cable.
- e. Disconnect the patch cord from the Type 151 HORIZ OUTPUT jack.

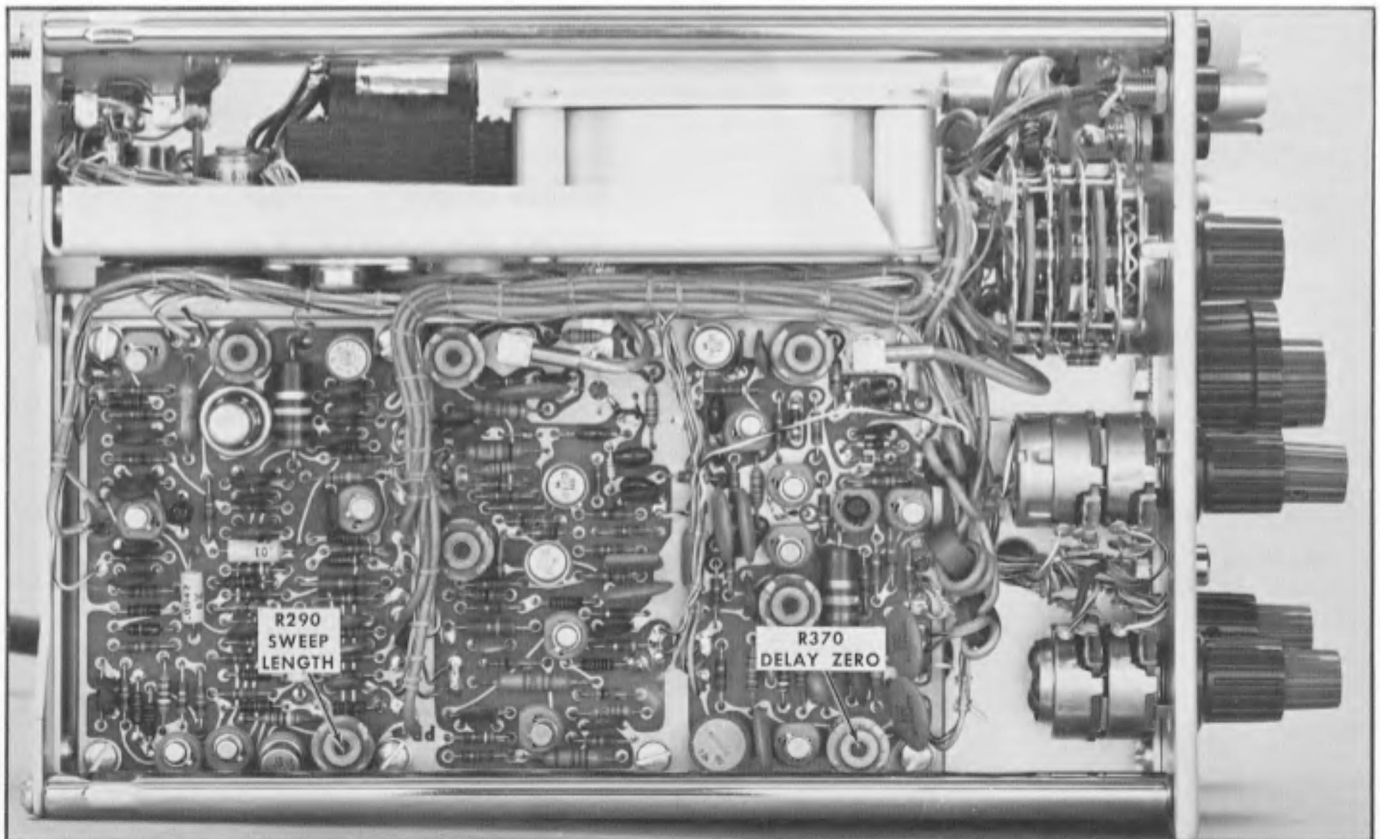

Fig. 5-24. Right side of Type 151 showing location of DELAY ZERO and SWEEP LENGTH controls. (Unit is positioned upside-down on test bench.)



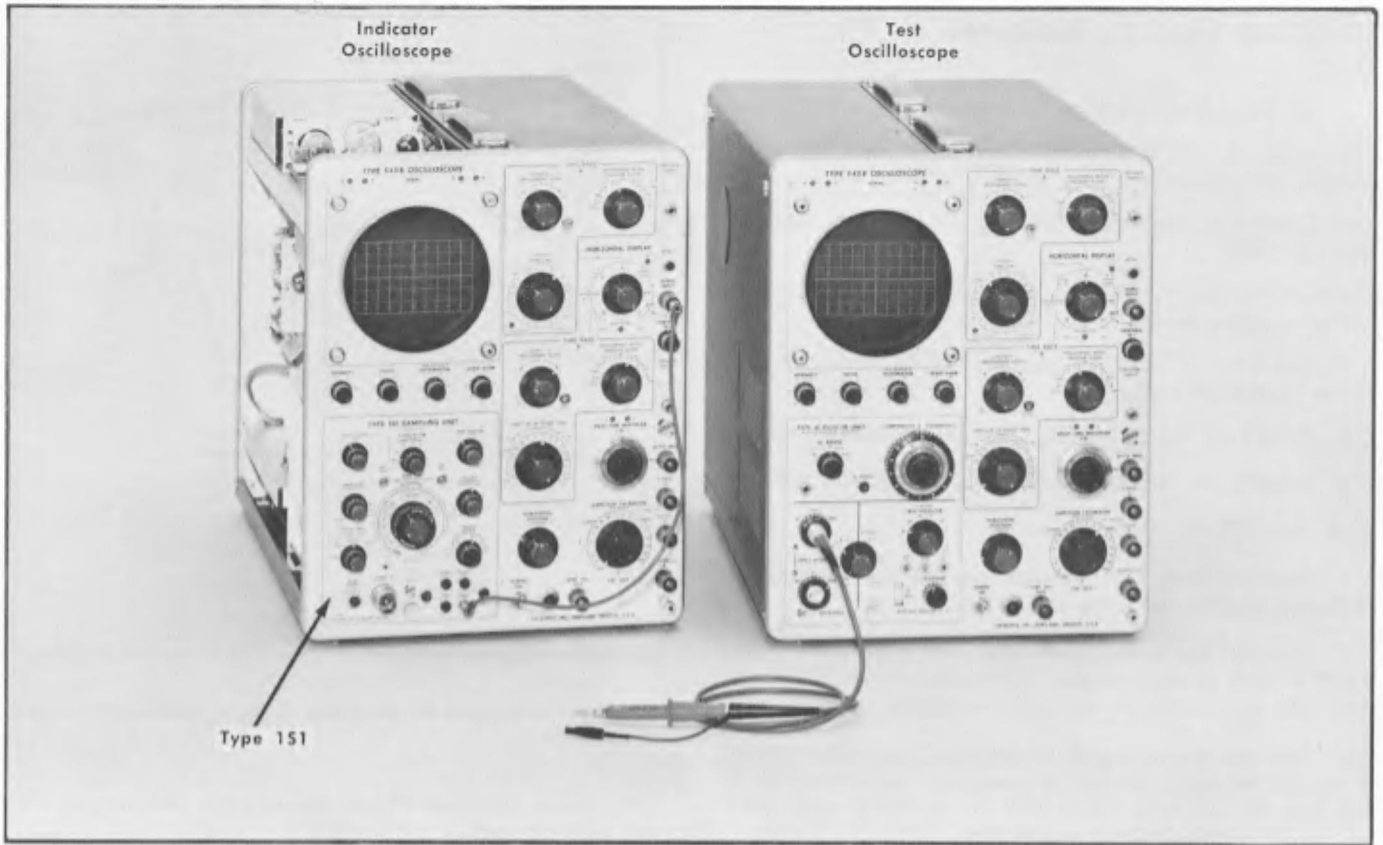

Fig. 5-26. Initial test equipment setup for steps 14 through 17.

<b>Type 151</b>		<b>Indicator Oscilloscope</b>	
mVOLTS/CM	200	Stability (both time bases)	Counterclockwise (not Preset)
mVolts/Cm VARIABLE	CAL	Horizontal Display	Ext Horiz Input
VERT POSITION	Centered	Intensity	Normal Brightness
DC OFFSET	Centered	Amplitude Calibrator	Off
<b>TIME POSITION</b>	<b>Centered</b>	Crt Cathode Selector	Chopped Blanking
<b>FINE</b>	<b>Centered</b>	<b>Test Oscilloscope</b>	
SMOOTHING	NORM (Clockwise)	Horizontal Display	A
SAMPLES/CM	Normal display	Time Base A controls:	
DISPLAY MODE	NORMAL	Trigger Slope	Int +
MANUAL SCAN		Triggering Mode	Ac
EXT HORIZ ATTN	Clockwise	<b>Stability</b>	<b>Clockwise</b>
<b>TIME/CM</b>	<b>10 nSEC</b>	<b>Triggering Level</b>	<b>Clockwise</b>
Time/Cm VARIABLE	CAL	<b>Time/Cm</b>	<b>1 mSec</b>
<b>TRIGGER SOURCE</b>	<b>INT +</b>	Time/Cm Variable	Calibrated (at detent)
TRIGGER SENSITIVITY	Clockwise	Time Base B Stability	Counterclockwise (not Preset)
RECOVERY TIME	Centered		



Amplitude Calibrator	Off
Display	A—Vc
<b>Millivolts/Cm</b>	<b>50</b>
Input Atten	1
Millivolts/Cm Variable	Calib (at detent)
Vc Range	0
Comparison Voltage	4.000
<b>Input Coupling (Channel A)</b>	<b>Gnd</b>
Input Coupling (Channel B)	Gnd

#### 14. Adjust Memory Balance

- a. Test equipment setup is shown in Fig. 5-26.
- b. With the Type 1S1 DC OFFSET control, position the trace near the center of the indicator oscilloscope crt screen.
- c. Turn the SMOOTHING control rapidly from one end of its range of rotation to the other end.
- d. Check that the indicator oscilloscope trace does not move vertically more than about 0.5 cm as the SMOOTHING control is turned.

e. Adjust R110 (MEMORY BAL) if operation of the SMOOTHING control is not correct. See Fig. 5-27 for the location of R110.

f. Reset the SMOOTHING control to NORM position (fully clockwise).

#### 15. Adjust Bridge Balance

a. Connect the test probe to the Type 1S1 OFFSET OUTPUT jack. (You may wish to use a banana plug tip on the probe for this connection.)

b. Free run the test oscilloscope trace and set it for a zero-volt dc reference level.

c. Set the test oscilloscope Input Coupling switch to Dc.

d. Adjust the Type 1S1 DC OFFSET control to position the test oscilloscope trace at the zero reference level, indicating a dc level of zero volts at the OFFSET OUTPUT jack.

e. Switch the Type 1S1 mVOLTS/CM switch to each of its 7 positions.

f. Check that the indicator oscilloscope trace does not move more than about  $\pm 2$  cm as the switch is turned throughout its range.

g. Adjust R30 (BRIDGE BAL) if operation of the switch is not correct. See Fig. 5-27 for the location of R30.

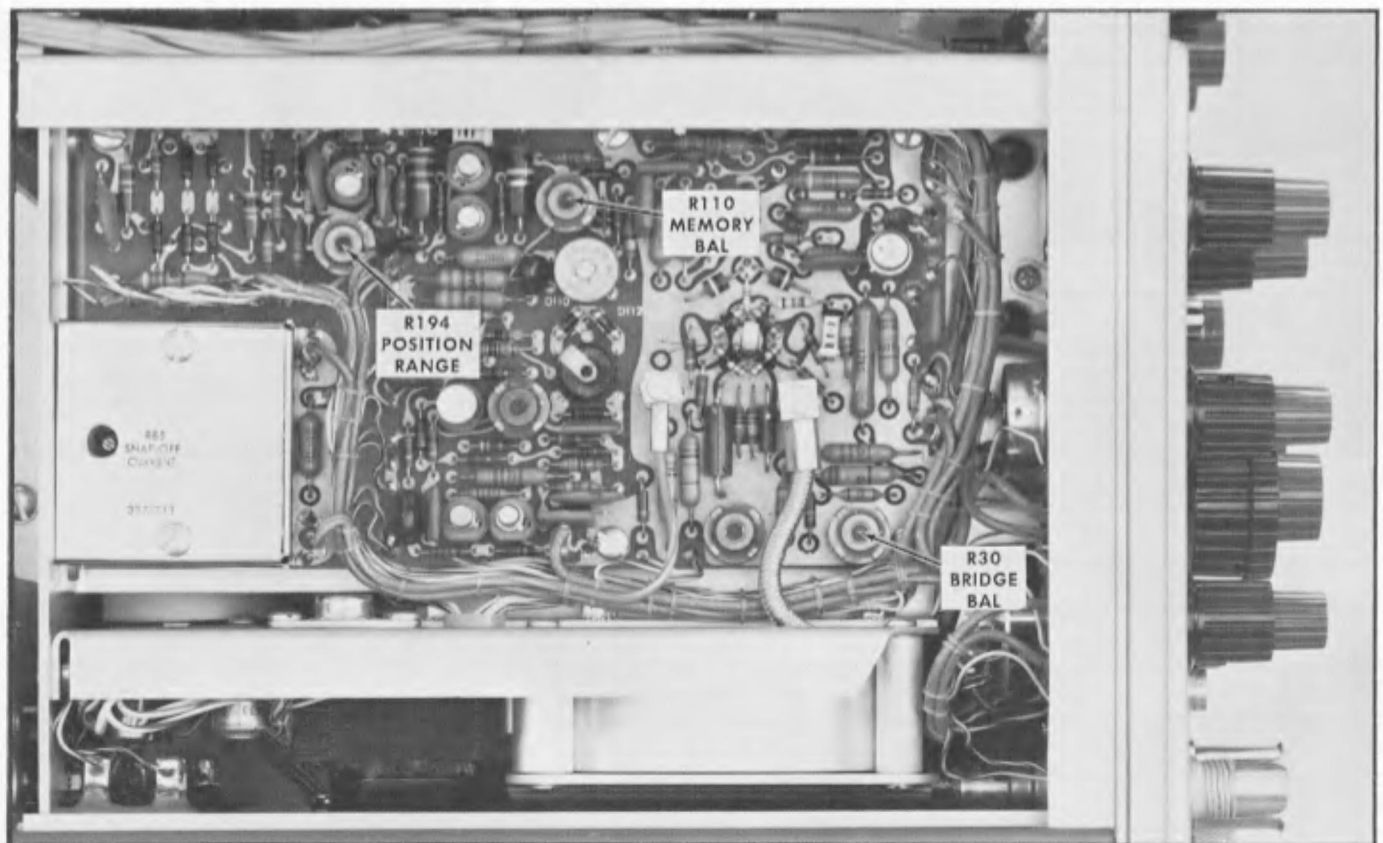

Fig. 5-27. Location of balance adjustment controls on left side of Type 1S1. (Unit is installed in indicator oscilloscope.)

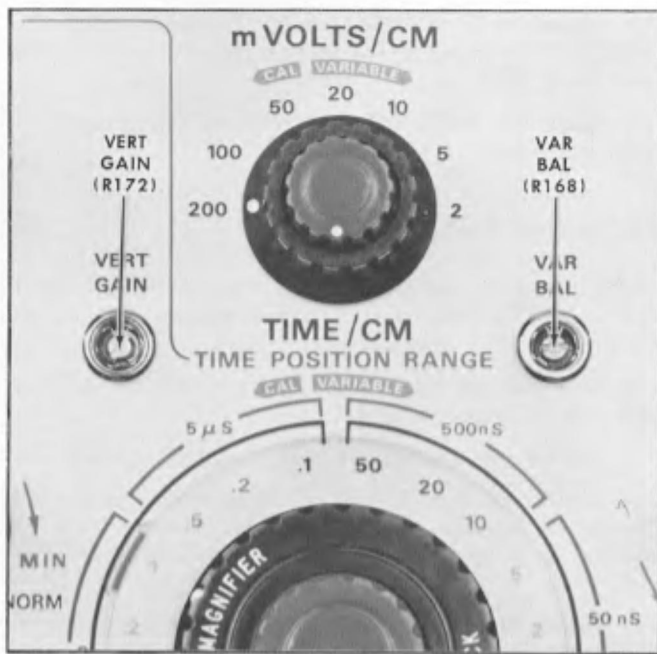

Fig. 5-28. VAR BAL and VERT GAIN screwdriver-adjust controls on Type 1S1 front panel.

### 16. Adjust Variable Balance



- a. Continue monitoring the OFFSET OUTPUT voltage with the test oscilloscope.
- b. Recheck the zero dc reference level of the test oscilloscope, then set the Input Coupling switch to Dc.

c. Recheck the OFFSET OUTPUT for zero volts on the test oscilloscope crt screen and adjust the Type 1S1 DC OFFSET control if the voltage is not correct.

d. Set the Type 1S1 mVOLTS/CM switch to 50.

e. Turn the mVolts/Cm VARIABLE control through its range of rotation.

f. Check that the indicator oscilloscope trace does not move more than about 0.2 cm as the control is turned.

g. Adjust the front-panel VAR BAL screwdriver-adjust control (see Fig. 5-28) if operation of the VARIABLE control is not correct.

h. Set the mVolts/Cm VARIABLE control to CAL position.

### 17. Adjust Position Range



a. Leave the DC OFFSET control set for zero volts at the OFFSET OUTPUT jack.

b. Center the Type 1S1 VERT POSITION control knob so that the white dot is pointing straight up.

c. Check that the trace is approximately centered ( $\pm 1/2$  cm) on the indicator oscilloscope crt screen.

d. Adjust R194 (POSITION RANGE) to position the trace at the horizontal centerline if it was not already within  $1/2$  cm of the centerline. See Fig. 5-27 for the location of R194.

e. Disconnect the test probe from the OFFSET OUTPUT jack.

### NOTES

---

---

---

---

---

---

---

---

---

---

---

---

---

---

---

---

---

---

---

---

---

---

---

---





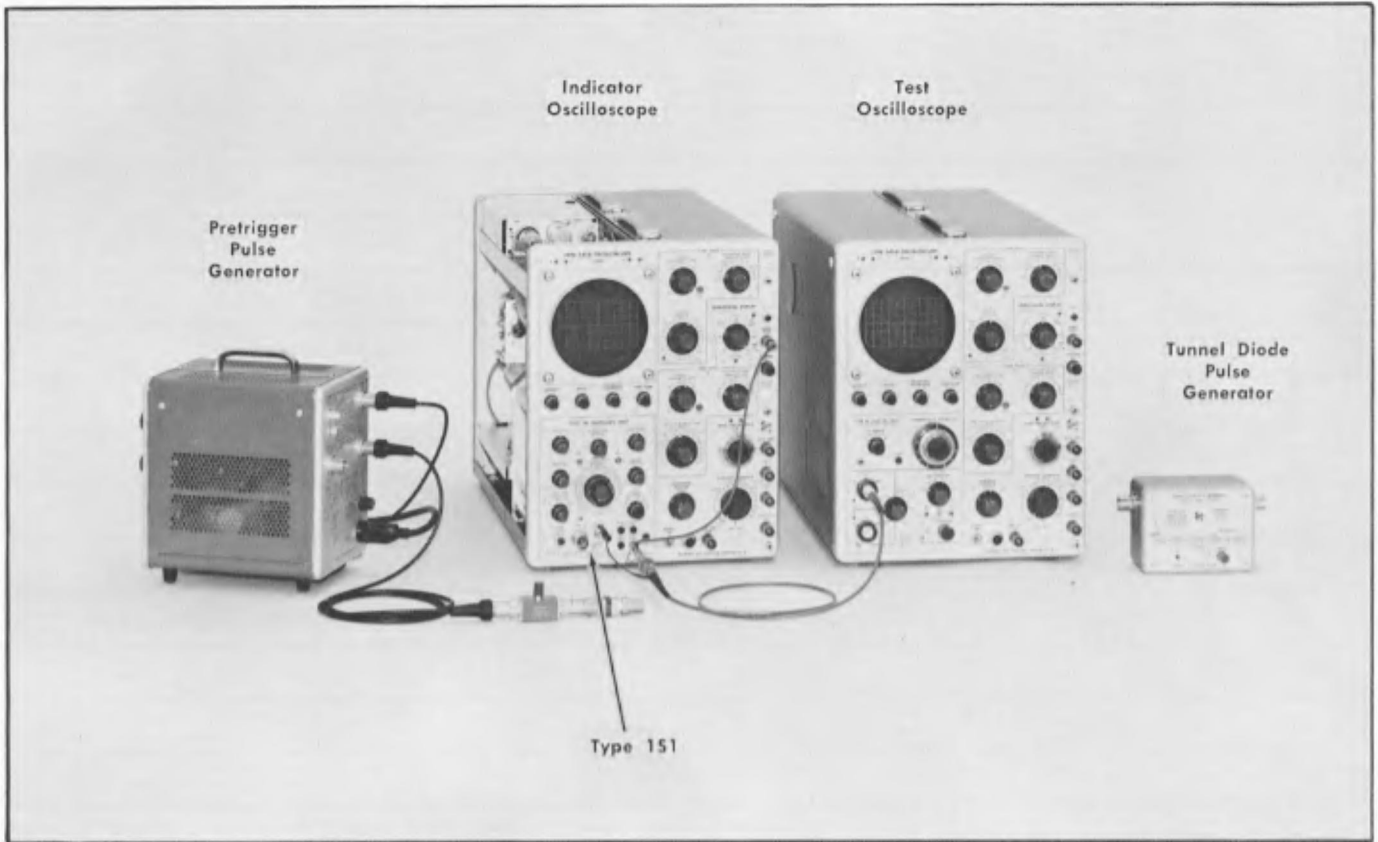

Fig. 5-29. Initial test equipment setup for steps 18 through 20.

**Type 151**

<b>mVOLTS/CM</b>	<b>200</b>
mVolts/Cm VARIABLE	CAL
VERT POSITION	Centered
DC OFFSET	Centered
TIME POSITION	Centered
FINE	Centered
SMOOTHING	NORM (Clockwise)
<b>SAMPLES/CM</b>	<b>MIN (Clockwise)</b>
<b>DISPLAY MODE</b>	<b>SINGLE SWEEP</b>
MANUAL SCAN	
EXT HORIZ ATTEN	Clockwise
<b>TIME/CM</b>	<b>5 nSEC</b>
Time/Cm VARIABLE	CAL
TRIGGER SOURCE	INT +
TRIGGER SENSITIVITY	Clockwise
RECOVERY TIME	Centered

**Indicator Oscilloscope**

Stability (both time bases)	Counterclockwise (not Pre-set)
Horizontal Display	Ext Horiz Input
Amplitude Calibrator	Off
Crt Cathode Selector	Chopped Blanking

**Test Oscilloscope**

Horizontal Display	A
Time Base A controls:	
Trigger Slope	Int +
Triggering Mode	Ac
Stability	Clockwise
Triggering Level	Clockwise
<b>Time/Cm</b>	<b>5 μSEC</b>
Time/Cm Variable	Calibrated (at detent)
Time Base B Stability	Counterclockwise (not Pre-set)

Amplitude Calibrator	Off
Display	A—Vc
<b>Millivolts/Cm</b>	<b>5</b>
Input Atten	1
Millivolts/Cm Variable	Calib (at detent)
Vc Range	0
Comparison Voltage	4.000
<b>Input Coupling (Channel A)</b>	<b>Ac</b>
Input Coupling (Channel B)	Gnd

**Pretrigger Pulse Generator**

Repetition Rate	Centered
Range	10 Kc
Output Polarity	+

**18. Adjust Loop Gain**

(Steps b through q establish a synchronous 2-trace pulse display for adjusting the controls that affect sampling loop gain).<sup>1</sup>

- a. Test equipment setup is shown in Fig. 5-29.
- b. Connect the tip of the test probe to the Type 1S1 HORIZ OUTPUT jack.
- c. Trigger the test oscilloscope display.
- d. Measure and record the approximate time interval between alternate pulses on the waveform at the HORIZ OUTPUT jack (see Fig. 5-30A).
- e. Set the test oscilloscope Input Atten switch to 100.
- f. Touch the tip of the test probe to the pulse generator Pretrigger Output connector.
- g. Trigger the test oscilloscope display.
- h. Adjust the pulse generator Repetition Rate control to produce a time interval between pulses equal to the approximate interval between alternate cycles of the waveform at the Type 1S1 HORIZ OUTPUT jack (see Fig. 5-30B). You may wish to record this setting of the Repetition Rate control for future reference, such as in step 31. Record the knob position as the number of degrees from center position (e.g. 95° clockwise from center).
- i. Remove the test probe from the Pretrigger Output.
- j. Connect the Pulse Output signal of the pretrigger pulse generator through a coax cable, the variable attenuator and a 5X attenuator to the SIGNAL IN connector of the Type 1S1. (The Type 111 Pretrigger Pulse Generator should have a 9-nsec charge line installed, for an Output Pulse duration of 20 nsec.)

<sup>1</sup>A modified Type 111 Pretrigger Pulse Generator (067-0517-00) is available to provide an automatic 2-trace pulse display for these adjustments. See your Tektronix Field Engineer for details.

- k. Set the variable attenuator control to midrange.
- l. Set the Type 1S1 DISPLAY MODE switch to NORMAL.
- m. Trigger the display with the Type 1S1 TRIGGER SENSITIVITY control. (It may be necessary to increase the display intensity to observe the triggered trace.)
- n. Adjust the Type 1S1 SAMPLES/CM control for a normal continuous display.

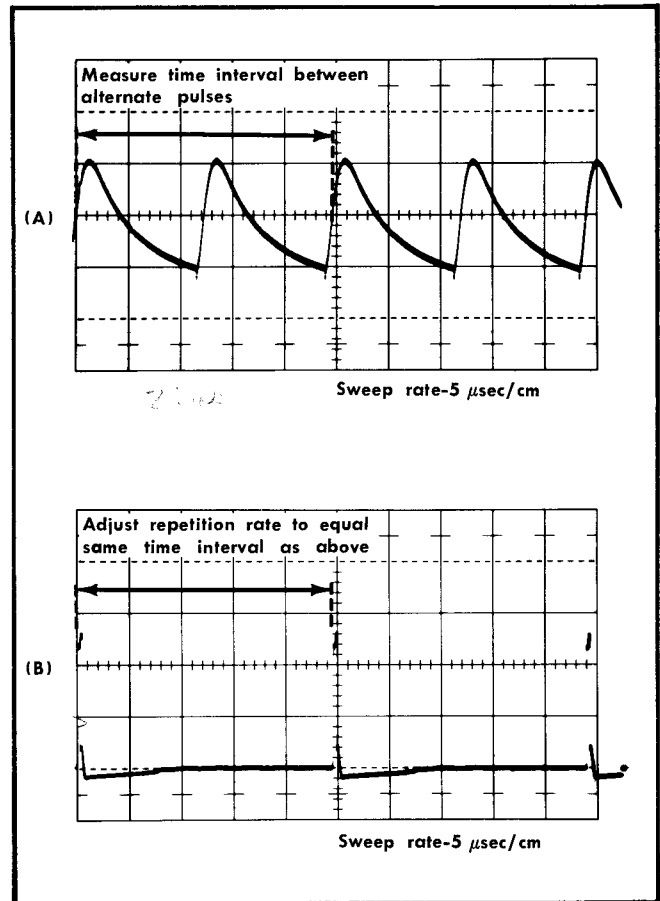

Fig. 5-30. Typical test oscilloscope displays for adjusting pretrigger pulse generator repetition rate to produce 2 trace sampling display. (A) Waveform at Type 1S1 HORIZ OUTPUT (B) pretrigger pulse of pretrigger pulse generator.

- o. Position the pulse to the center of the screen with the TIME POSITION and DC OFFSET controls.
- p. Adjust the variable attenuator for approximately 5 cm of vertical deflection on the indicator oscilloscope crt (see Fig. 5-31A).
- q. Set the Type 1S1 SMOOTHING control fully counter-clockwise.
- r. Turn the TRIGGER SENSITIVITY control fully clockwise.
- s. Adjust the RECOVERY TIME control to obtain a 2-trace display as shown in Fig. 5-31B). Stability of the display may be improved by slight readjustment of the TRIGGER SENSITIVITY and RECOVERY TIME controls.
- t. Turn the SMOOTHING control fully clockwise.

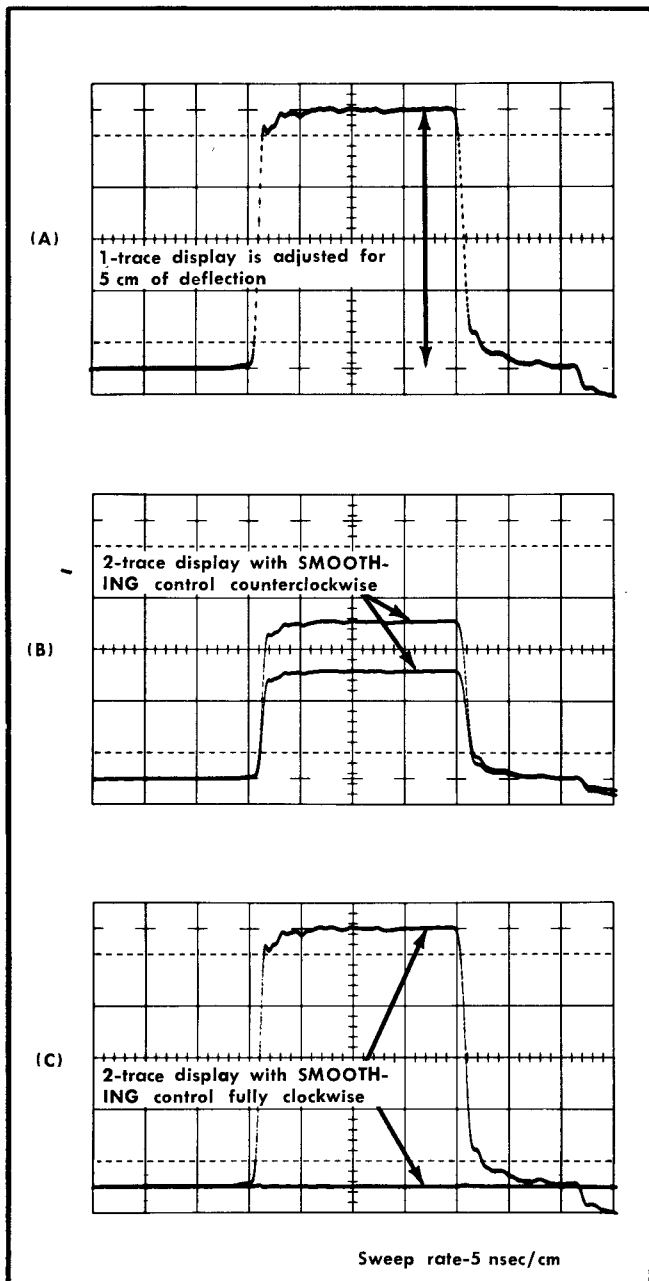

Fig. 5-31. Typical indicator oscilloscope displays for setting up 2-trace display and checking loop gain.

u. Check for a waveform similar to that shown in Fig. 5-31C). The line at the base should be at the same level as the baseline of the pulse.

v. If the loop gain waveform is not correct:

1. Check the adjustment of R95 (MEMORY GATE WIDTH) by turning the control slightly each way from its original position and observing the change in the waveform. See Fig. 5-33 for the location of R95.

2. Adjust R95 to the point of maximum gain (see Fig. 5-32A-C). Maximum gain is observed as the greatest separation between the two displayed traces.

3. Adjust C135 to set the loop gain at unity (gain of

- 1). This is indicated by a straight-line display of the lower trace (see Fig. 5-32B).

w. Set the pretrigger pulse generator Output Polarity switch to —.

x. Set the Type 1S1 TRIGGER SOURCE switch to INT—.

y. Check for a waveform indicating unity loop gain. The 2-trace separation should not change by more than 0.2 cm, as compared to the display with +polarity.

z. Set the pretrigger pulse generator Output Polarity switch back to +.

aa. Set the Type 1S1 TRIGGER SOURCE switch to INT+.

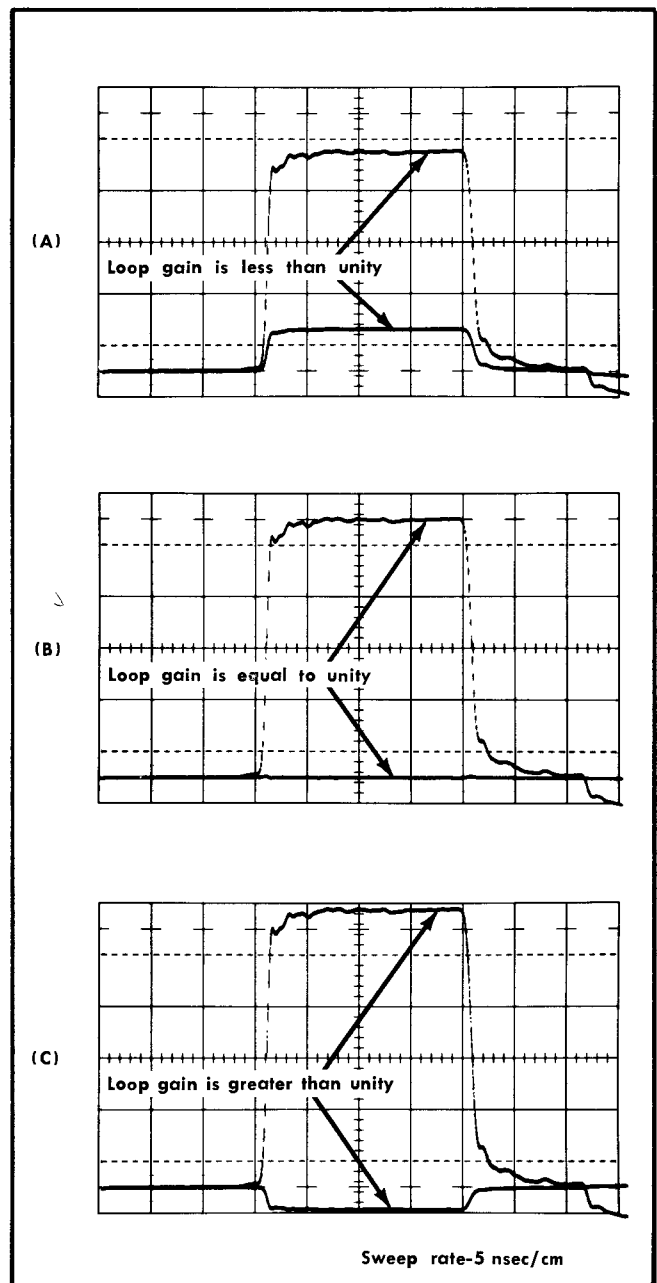

Fig. 5-32. Typical indicator oscilloscope displays for adjusting loop gain of Type 1S1.

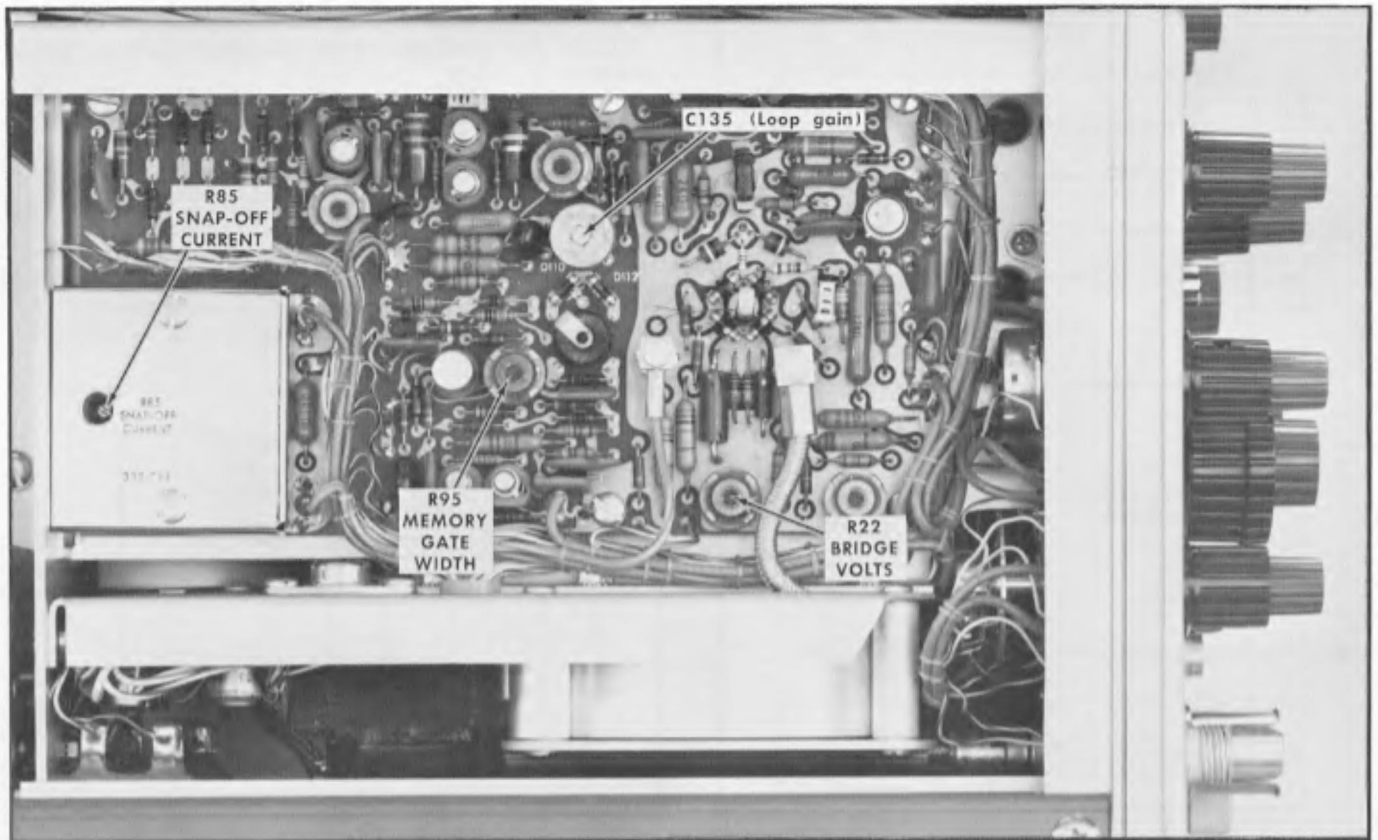

Fig. 5-33. Adjustments on left side of Type 151 for loop gain, bridge standoff and risetime.

## 19. Adjust Bridge Standoff

a. Substitute a 2X attenuator for the 5X attenuator in the signal connection from the pretrigger pulse generator to the Type 151 SIGNAL IN connector.

b. Set the Type 151 TRIGGER SENSITIVITY control to produce a triggered (1-trace) display.

c. Reset the following test oscilloscope controls:

Time/Cm	5 mSEC
Input Atten	1
Input Coupling	Dc
Millivolts/Cm	50

d. Connect the test probe to the Type 151 VERT OUTPUT jack.

e. Trigger the test oscilloscope display.

f. Adjust the Type 151 SAMPLES/CM and TIME POSITION controls to produce a display similar to Fig. 5-34A on the crt of the test oscilloscope.

g. Position the baseline of the displayed pulse 2 cm below the center of the test oscilloscope screen.

h. Increase the pulse amplitude into the Type 151 with the variable attenuator until the baseline immediately following the pulse in the test oscilloscope display begins to rise. (See Fig. 5-34B).

i. Back off on the pulse amplitude to the point where the baseline just started to rise.

j. Check the test oscilloscope waveform for an amplitude of 2 volts or more (4 cm or more).

k. If the pulse amplitude is less than 2 volts:

1. Adjust the variable attenuator for a display amplitude of 2.2 volts (4.4 cm) on the test oscilloscope screen.

2. Adjust R22 (BRIDGE VOLTS) counterclockwise slowly until the baseline immediately following the pulse (Fig. 5-34B) stops moving downward.

### NOTE

It is suggested that the bridge voltage not be set excessively high, since random noise of the system is increased by this adjustment.

3. Recheck the standoff voltage as in steps g through j above.

4. Disconnect the input signal temporarily.

5. Readjust R30 (BRIDGE BAL) as described in step 15.

6. Reconnect the pulse signal to the Type 151 SIGNAL IN connector.

7. Readjust loop gain as described in steps 18 p through 18 v. (This can be done with the 2X attenuator with overshoot on the leading edge, or the 5X attenuator may be substituted temporarily.)

8. Connect the test probe to the Type 151 VERT OUTPUT jack again.

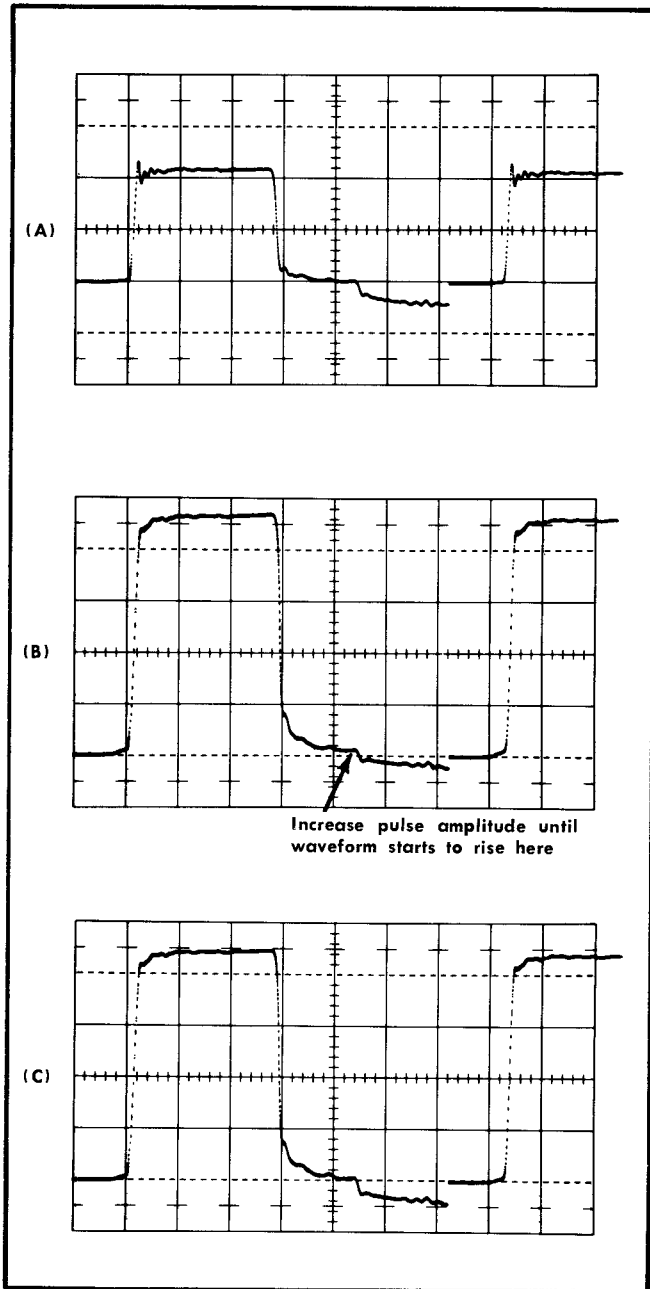

Fig. 5-34. Typical test oscilloscope displays for checking sampling bridge standoff voltage.

- l. Switch the pretrigger pulse generator Output Polarity switch to —.
- m. Set the Type 1S1 TRIGGER SOURCE switch to INT —.
- n. Trigger the display (1-trace) with the Type 1S1 TRIGGER SENSITIVITY control.
- o. Trigger the test oscilloscope display.
- p. Check for a standoff voltage of at least 2 volts with a negative-going pulse, as described in steps g through j above (for a positive-going pulse). The final setting of R22 must provide at least +2 volts and -2 volts of standoff with the bridge balanced.

- q. Remove the test probe.
- r. Set the pretrigger pulse generator Output Polarity switch to +.
- s. Leave the Type 1S1 TRIGGER SOURCE switch set to INT—.

## 20. Adjust Risetime

- a. Disconnect the pretrigger pulse generator signal from the Type 1S1 SIGNAL IN connector, but leave the connections and controls set as in step 17. If readjustment of risetime is required, loop gain will also have to be readjusted.

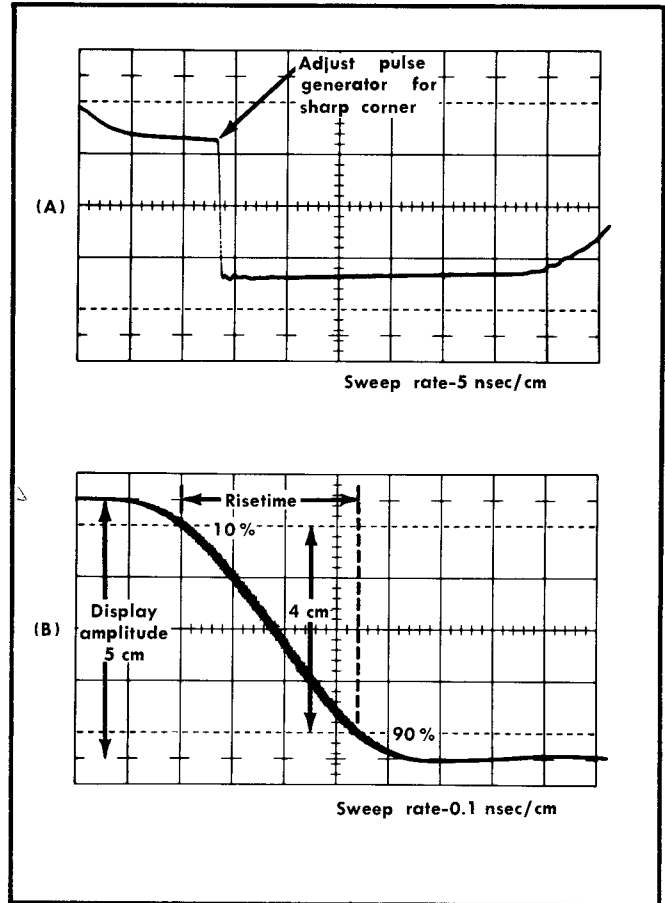

Fig. 5-35. Indicator oscilloscope waveforms for checking risetime of the Type 1S1.

- b. Connect the tunnel diode pulse generator to the Type 1S1 SIGNAL IN connector.
- c. Turn on the tunnel diode pulse generator.
- d. Trigger the indicator oscilloscope display with the Type 1S1 TRIGGER SENSITIVITY control.
- e. Position the negative-going pulse rise on the indicator oscilloscope screen with the TIME POSITION, FINE and DC OFFSET controls.
- f. Adjust the tunnel diode pulse generator Drive control for a sharp corner at the start of the rise (see Fig. 5-35A).



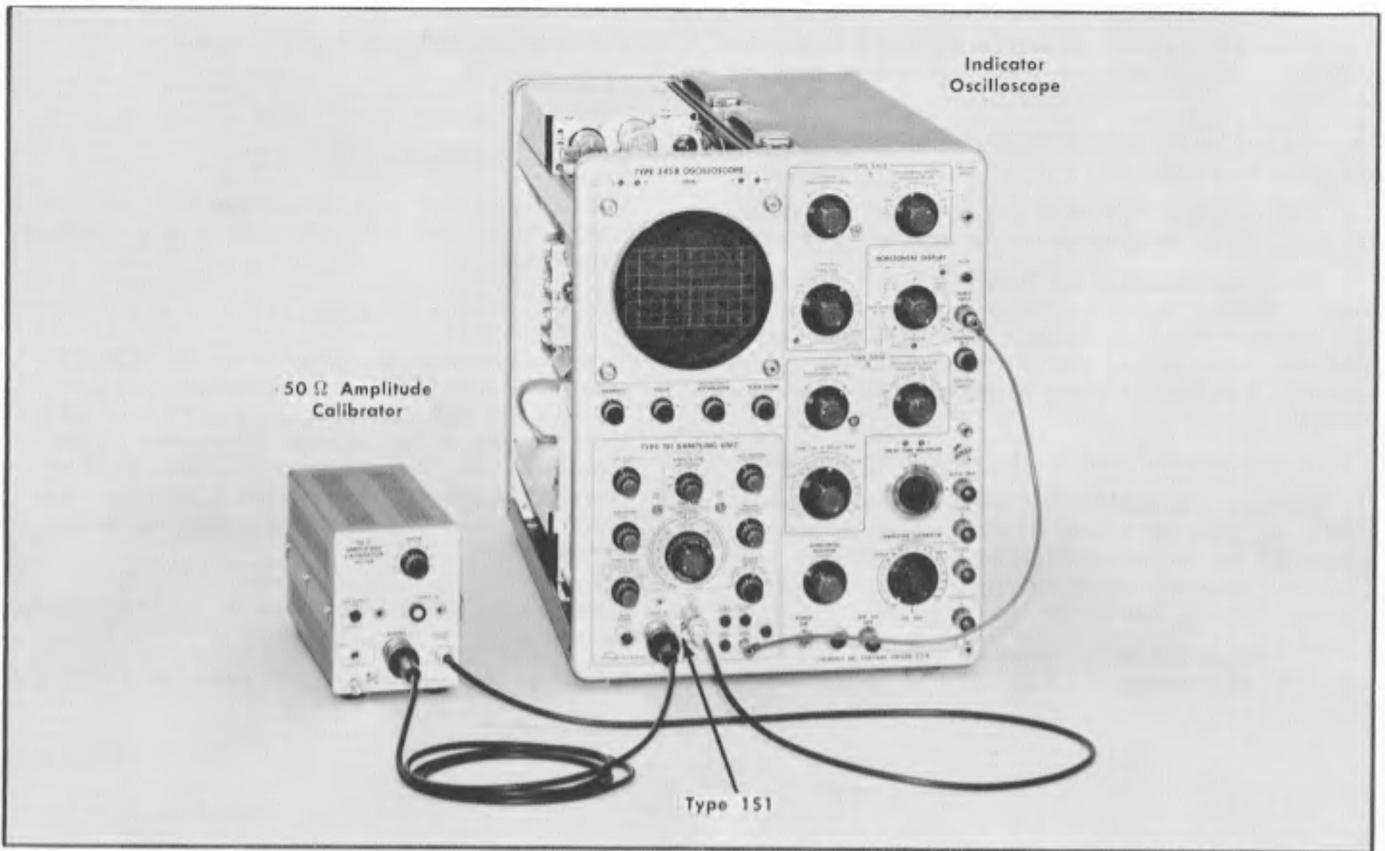

Fig. 5-36 Initial test equipment setup for steps 21 through 23.

	<b>Type 151</b>	<b>TIME/CM</b>	<b>5 μSEC</b>
mVOLTS/CM	200	Time/Cm VARIABLE	CAL
<b>mVolts/Cm VARIABLE</b>	<b>CAL</b>	<b>TRIGGER SOURCE</b>	<b>EXT +</b>
VERT POSITION	Centered	<b>TRIGGER SENSITIVITY</b>	<b>Clockwise</b>
DC OFFSET	Centered	RECOVERY TIME	Centered
<b>TIME POSITION</b>	<b>Centered</b>	<b>Indicator Oscilloscope</b>	
<b>FINE</b>	<b>Centered</b>	Stability (both time bases)	Counterclockwise (not Pre-set)
SMOOTHING	NORM (Clockwise)	Horizontal Display	Ext Horiz Input
SAMPLES/CM	Normal display	Intensity	Normal Brightness
DISPLAY MODE	NORMAL	Amplitude Calibrator	Off
MANUAL SCAN		Crt Cathode Selector	Chopped Blanking
EXT HORIZ ATTEN	Clockwise		



## 21. Adjust Vertical Gain



- a. Test equipment setup is shown in Fig. 5-36.
- b. Connect a coax cable from the 50 Ω amplitude calibrator Output connector to the SIGNAL IN connector of the Type 1S1.
- c. Connect the 50 Ω amplitude calibrator Trigger Output signal through a coax cable and a 2X attenuator (BNC connectors) to the Type 1S1 EXT TRIG connector.
- d. Set the 50 Ω amplitude calibrator VOLTS switch to the .6 position.
- e. Trigger the display with the TRIGGER SENSITIVITY control.
- f. Position the waveform with the DC OFFSET control so the baseline is on the graticule line 1 cm below the horizontal centerline (see Fig. 5-37).
- g. Check the display amplitude for 3.00 cm of vertical deflection  $\pm 0.09$  cm.
- h. Adjust the front-panel VERT GAIN screwdriver-adjust control if the display amplitude is not correct.

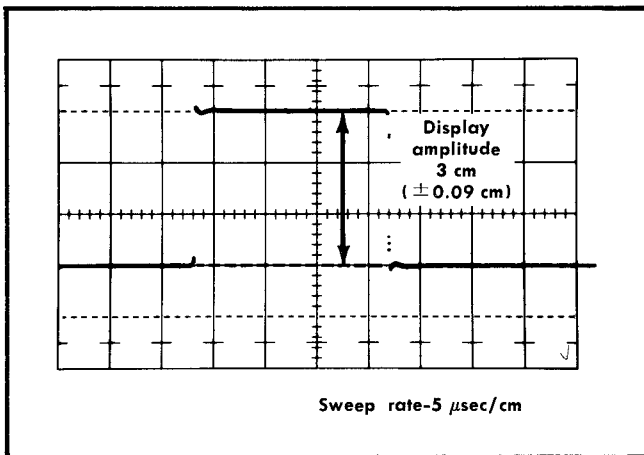

Fig. 5-37. Typical indicator oscilloscope display for checking adjustment of VERT GAIN control.

### VERTICAL CHECKS

## 22. Check mVolts/Cm Accuracy

- a. Leave the signal and trigger cables connected to the Type 1S1 SIGNAL IN and EXT TRIG connectors.
- b. Set the Type 1S1 mVOLTS/CM switch to each position from 100 to 2 and check the attenuator accuracy as indicated in Table 5-1. The deflection factor should be within 3% of the amount indicated at each setting of the mVOLTS/CM switch. If it is not, the VERT GAIN control may require slight readjustment.

## 23. Check mVolts/Cm Variable

- a. Leave the 50 Ω amplitude calibrator signals connected to the Type 1S1.
- b. Set the Type 1S1 mVOLTS/CM switch to 200.

TABLE 5-1  
mVOLTS/CM Accuracy Check

mVOLTS/CM	50 Ω Amplitude Calibrator	Display Amplitude	Tolerance
100	.3 Volts	3.0 cm	$\pm 0.09$ cm
50	.12 Volts	2.4 cm	$\pm 0.07$ cm
20	.06 Volts	3.0 cm	$\pm 0.09$ cm
10	.03 Volts	3.0 cm	$\pm 0.09$ cm
5	.012 Volts	2.4 cm	$\pm 0.07$ cm
2	.012 Volts	3.0 cm*	$\pm 0.09$ cm*

\*Insert 2X attenuator for reading, then remove attenuator. (Attenuator inaccuracy must be added to deflection factor tolerance.)

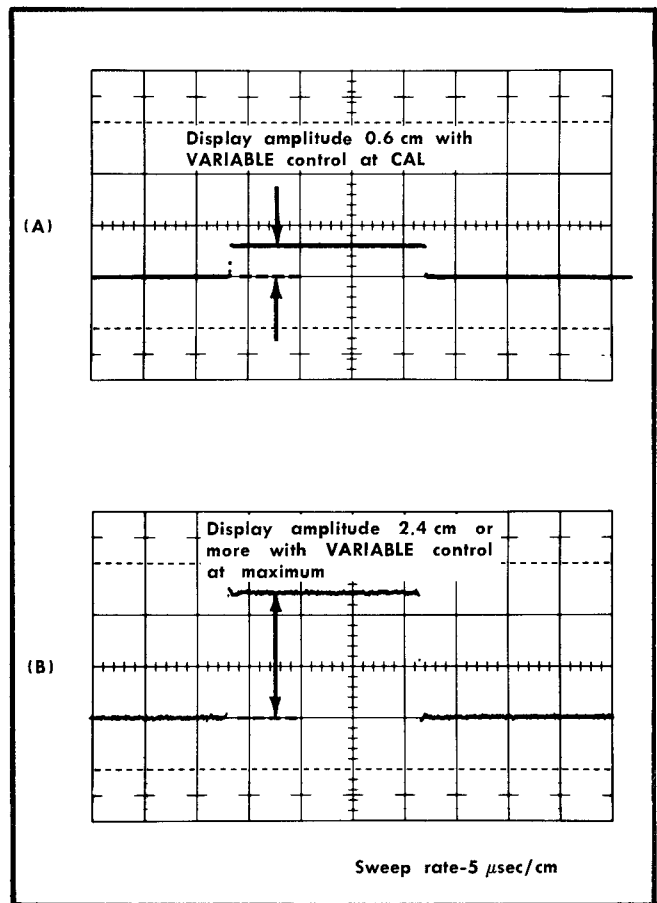

Fig. 5-38. Indicator oscilloscope displays for checking mVolts/Cm VARIABLE control.

- c. Set the amplitude calibrator Volts switch to the .12 position.
- d. Trigger the oscilloscope display with the Type 1S1 TRIGGER SENSITIVITY control. Display amplitude should be 0.6 cm (see Fig. 5-38A).
- e. Set the mVolts/Cm VARIABLE control for maximum display amplitude.
- f. Check for at least 2.4 cm of deflection, indicating a 4:1 increase from the calibrated position (see Fig. 5-38B).
- g. Return the VARIABLE control to CAL position.

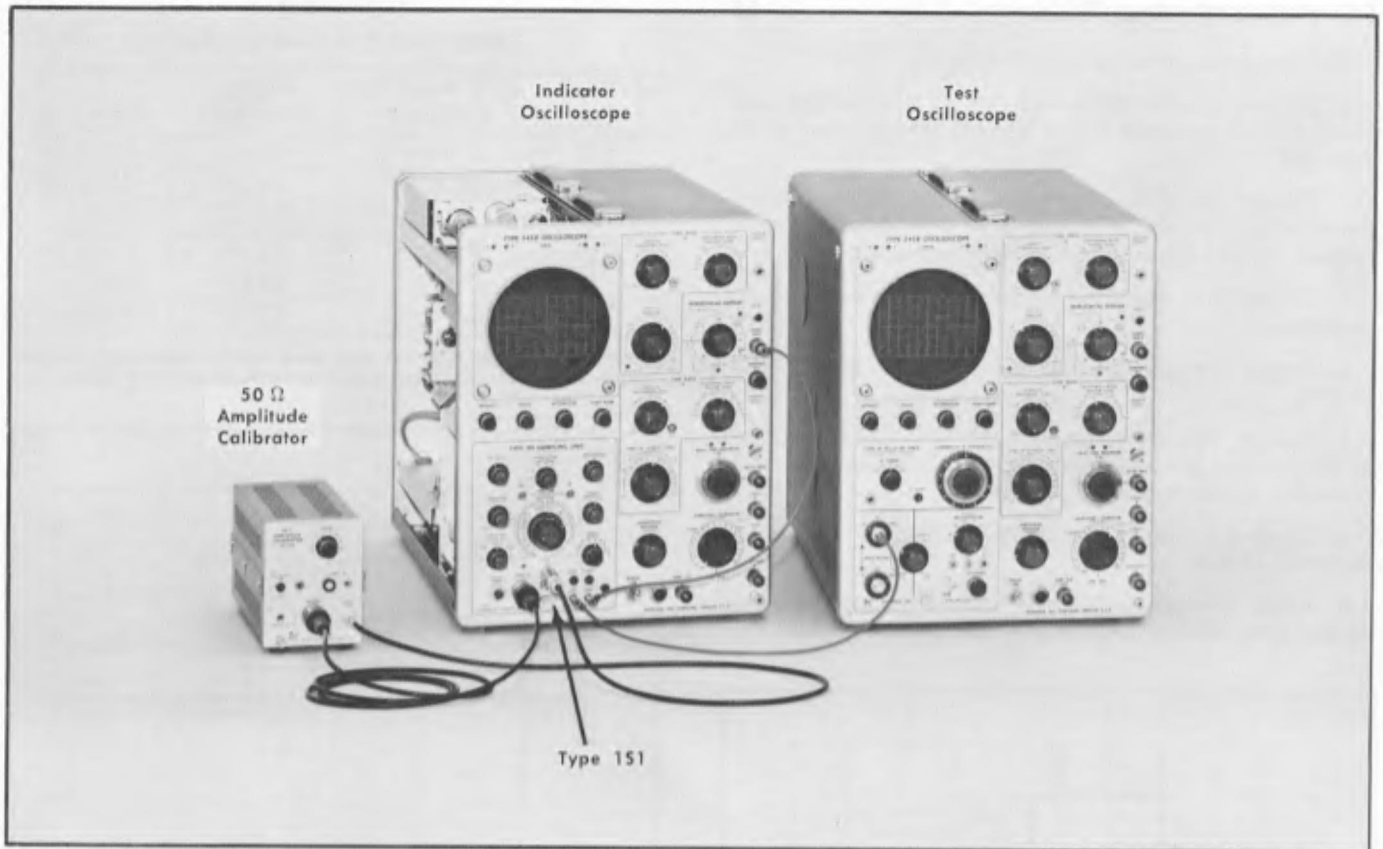

Fig. 5-39. Initial test equipment setup for steps 24 through 26.

Type 151	
mVOLTS/CM	200
mVolts/Cm VARIABLE	CAL
VERT POSITION	Centered
DC OFFSET	Centered
TIME POSITION	Centered
FINE	Centered
SMOOTHING	NORM (Clockwise)
<b>SAMPLES/CM</b>	<b>MIN (Clockwise)</b>
DISPLAY MODE	NORMAL
MANUAL SCAN	
EXT HORIZ ATTEN	Clockwise
TIME/CM	5 μSEC
Time/Cm VARIABLE	CAL
TRIGGER SOURCE	EXT +
<b>TRIGGER SENSITIVITY</b>	<b>Clockwise</b>
RECOVERY TIME	Centered

Indicator Oscilloscope	
Stability (both time bases)	Counterclockwise (not Pre-set)
Horizontal Display	Ext Horiz Input
Intensity	Normal Brightness
Amplitude Calibrator	Off
Crt Cathode Selector	Chopped Blanking

Test Oscilloscope	
Horizontal Display	A
Time Base A controls:	
Trigger Slope	Int +
Triggering Mode	Ac
<b>Stability</b>	<b>Clockwise</b>
<b>Triggering Level</b>	<b>Clockwise</b>
<b>Time/ Cm</b>	<b>5 mSEC</b>
Time/Cm Variable	Calibrated (at detent)
Time Base B Stability	Counterclockwise (not Pre-set)

Amplitude Calibrator	Off
Display	A—Vc
Millivolts/Cm	50
<b>Input Atten</b>	<b>10</b>
Millivolts/Cm Variable	Calib (at detent)
Vc Range	0
<b>Comparison Voltage</b>	<b>6.000</b>
Input Coupling (Channel A)	Dc
Input Coupling (Channel B)	Gnd

### 24. Check Vertical Output Accuracy

- a. Test equipment setup is shown in Fig. 5-36.
- b. Leave the 50 Ω amplitude calibrator signals connected to the Type 1S1.
- c. Disconnect the probe from the test oscilloscope vertical input.
- d. Connect a BNC/banana patch cord from the Type 1S1 VERT OUTPUT jack to the test oscilloscope vertical input connector.
- e. Set the amplitude calibrator Volts switch to the .6 position.
- f. Trigger the indicator oscilloscope display with the Type 1S1 TRIGGER SENSITIVITY control.
- g. Trigger the test oscilloscope display, obtaining a display similar to that shown in Fig. 5-40A. (The exact appearance of the waveform is not important.)
- h. Set the test oscilloscope Input Atten switch to  $R = \infty$ .
- i. Retrigger the test oscilloscope display.
- j. With the Type 1S1 DC OFFSET control, position the base of the test oscilloscope display at the horizontal centerline (see Fig. 5-40B).
- k. Set the test oscilloscope Vc Range switch to +1.1.
- l. Check that the top of the waveform is within 0.3 cm of the horizontal centerline. (See Fig. 5-40C). This indicates an amplitude of 600 mv ( $\pm 3\%$ ) at the Type 1S1 VERT OUTPUT jack, or 200 mv per cm of display on the screen of the indicator oscilloscope.
- m. Remove the patch cord from the VERT OUTPUT jack.

### 25. Check Offset Output Accuracy

- a. Leave the 50 Ω amplitude calibrator signals connected to the Type 1S1.
- b. Reset the following test oscilloscope controls:
 

Vc Range	0
Input Coupling	Gnd
Time/Cm	.1 mSEC

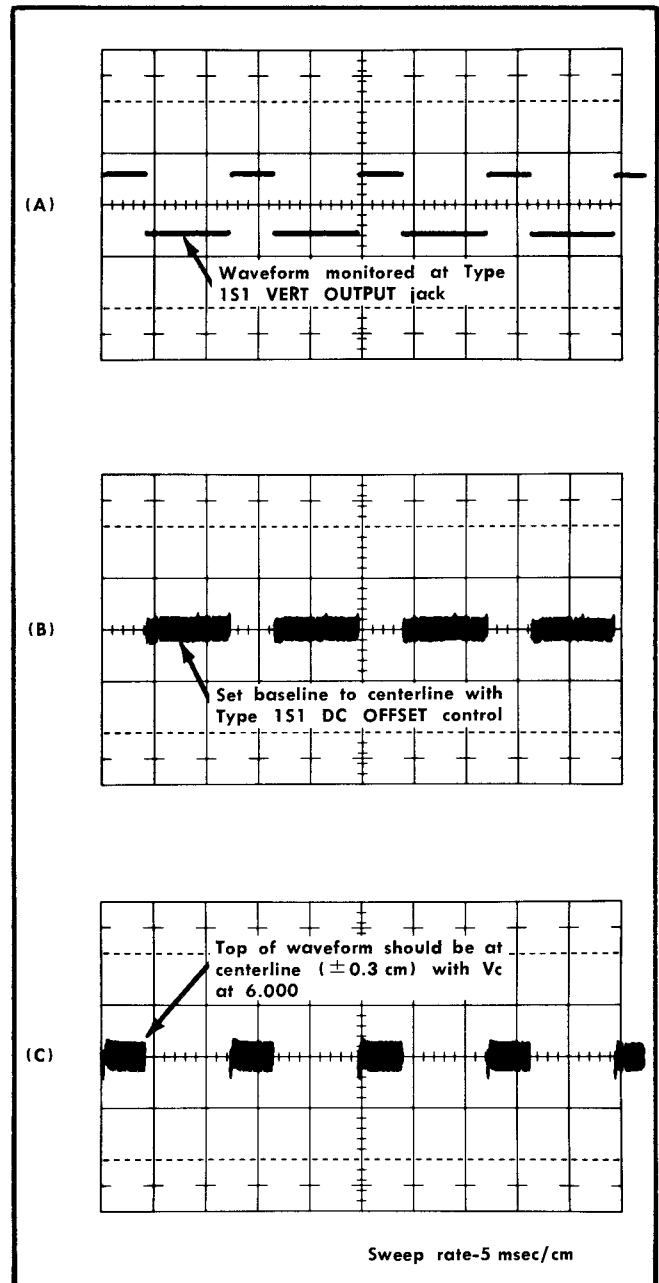

Fig. 5-40. Typical test oscilloscope displays for setting up vertical output accuracy measurement.

- c. Connect the BNC/banana patch cord from the Type 1S1 OFFSET OUTPUT jack to the test oscilloscope vertical input connector.
- d. Set the test oscilloscope for a free-running trace.
- e. Position the trace at the horizontal centerline with the test oscilloscope vertical Position control.
- f. Set the Input Coupling switch to Dc.
- g. With the Type 1S1 DC OFFSET control, reposition the test oscilloscope trace to the horizontal centerline.
- h. Adjust the Type 1S1 SAMPLES/CM control for a normal display on the indicator oscilloscope screen.

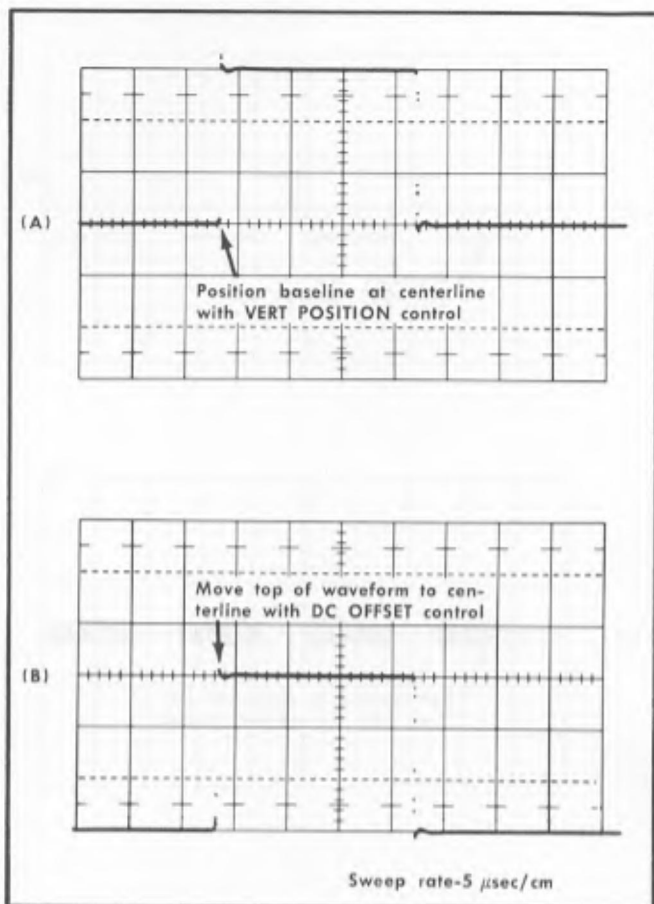

Fig. 5-41. Typical indicator oscilloscope displays obtained during check of offset output.

i. With the Type 1S1 VERT POSITION control, position the bottom of the waveform at the horizontal centerline of the indicator oscilloscope crt screen (see Fig. 5-41A).

j. With the Type 1S1 DC OFFSET control, position the top of the displayed waveform on the horizontal centerline of the indicator oscilloscope crt screen (see Fig. 5-41B).

k. Set the test oscilloscope Vc Range switch to +11.

l. Check that the trace on the test oscilloscope screen is within 2.4 cm of the horizontal centerline. This indicates a voltage excursion of 6 volts  $\pm 2\%$  at the Type 1S1 OFFSET OUTPUT jack, or 10 times the display voltage change produced by the DC OFFSET control.

m. Remove the patch cord from the OFFSET OUTPUT jack and the test oscilloscope vertical input.

n. Disconnect the coax cables and attenuator from the 50  $\Omega$  amplitude calibrator and from the Type 1S1 SIGNAL IN and EXT TRIG connectors.

## 26. Check Output DC Level

a. Install the 1X test probe on the test oscilloscope vertical input.

b. Reset the following test oscilloscope controls:

Vc Range	0
Input Atten	100
Comparison Voltage	6.700
Millivolts/Cm	10
Input Coupling	Gnd

c. Reset the following Type 1S1 controls:

TIME/CM	50 nSEC
TRIGGER SENSITIVITY	Clockwise
DISPLAY MODE	EXT HORIZ

d. Adjust the indicator oscilloscope Intensity control for a dim spot.

e. Free run the test oscilloscope trace and set it for a zero-volt dc reference level.

f. Set the test oscilloscope Input Coupling switch to Dc.

g. Touch the test probe tip to the Type 1S1 OFFSET OUTPUT jack.

h. Adjust the Type 1S1 DC OFFSET control to position the test oscilloscope trace to its horizontal centerline.

i. Touch the test probe to the junction of D183 and D185 (see Fig. 5-42).

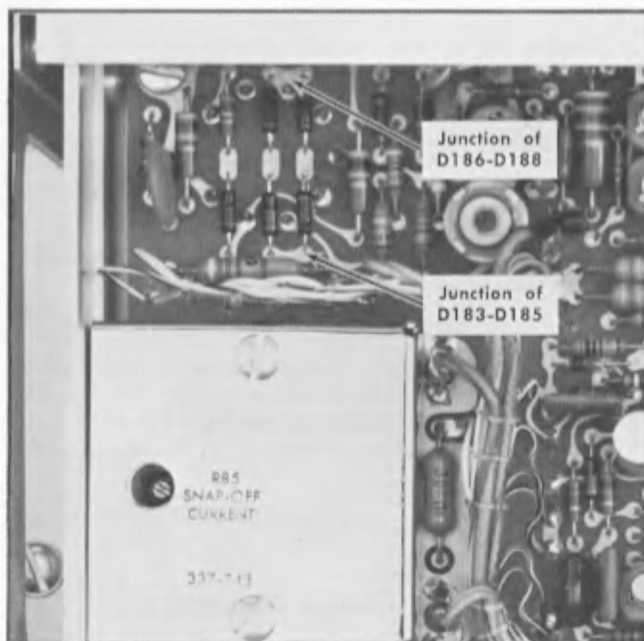

Fig. 5-42. Left side of Type 1S1 showing test points for checking dc vertical output voltage.

j. Set the Vc Range switch to +1.1.

k. Check that the test oscilloscope trace is now within

2.5 cm of the horizontal centerline, indicating a dc voltage of +67.5 volts  $\pm$ 2.5 volts.

l. Touch the test probe to the junction of D186 and D188 (see Fig. 5-42.)

m. Check that the test oscilloscope trace is within 2.5 cm

of the horizontal centerline, indicating a dc voltage of +67.5 volts  $\pm$ 2.5 volts.

n. Remove the probe from the test point.

o. Disconnect the 1X probe from the test oscilloscope vertical input.

NOTES

Lined area for notes with horizontal ruling lines.

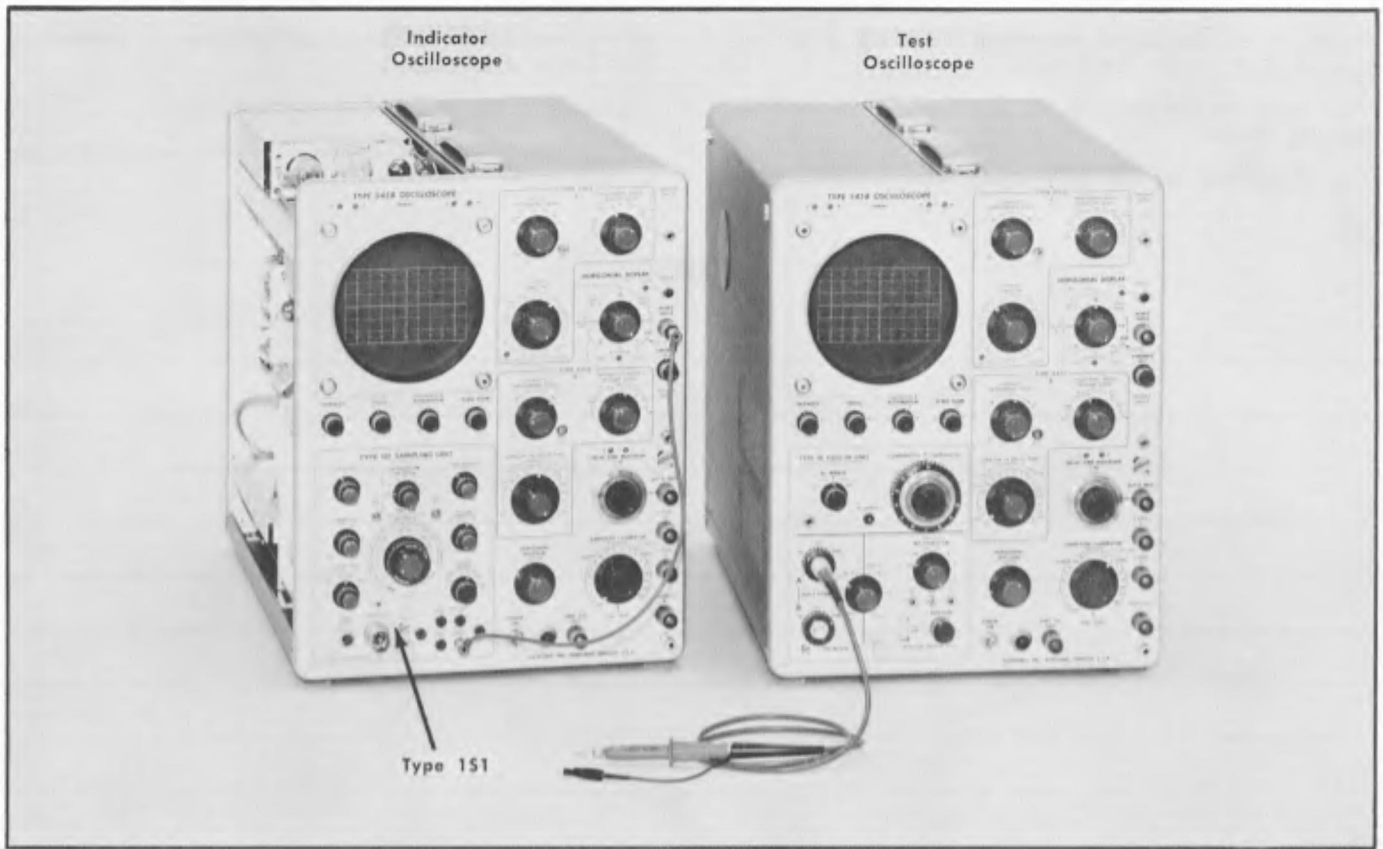

Fig. 5-43. Initial test equipment setup for steps 27 and 28.

<b>Type 151</b>	
mVOLTS/CM	200
mVolts/Cm VARIABLE	CAL
VERT POSITION	Centered
DC OFFSET	Centered
TIME POSITION	Centered
FINE	Centered
SMOOTHING	NORM (Clockwise)
SAMPLES/CM	Normal Display
<b>DISPLAY MODE</b>	<b>NORMAL</b>
MANUAL SCAN	
EXT HORIZ ATTN	Clockwise
TIME/CM	50 nSEC
Time/Cm VARIABLE	CAL
<b>TRIGGER SOURCE</b>	<b>INT +</b>
TRIGGER SENSITIVITY	Clockwise
RECOVERY TIME	Centered

<b>Indicator Oscilloscope</b>	
Stability (both time bases)	Counterclockwise (not Preset)
Horizontal Display	Ext Horiz Input
Intensity	Normal Brightness
Amplitude Calibrator	Off
Crt Cathode Selector	Chopped Blanking

<b>Test Oscilloscope</b>	
Horizontal Display	A
Time Base A controls:	
Trigger Slope	Int +
Triggering Mode	Ac
<b>Stability</b>	<b>Clockwise</b>
<b>Triggering Level</b>	<b>Clockwise</b>
<b>Time/Cm</b>	<b>.5 mSec</b>
Time/Cm Variable	Calibrated (at detent)
Time Base B Stability	Counterclockwise (not Preset)

Amplitude Calibrator	Off
Display	A—Vc
Millivolts/Cm	10
<b>Input Atten</b>	<b>1</b>
Millivolts/Cm Variable	Calib (at detent)
<b>Vc Range</b>	<b>0</b>
<b>Comparison Voltage</b>	<b>6.000</b>
Input Coupling (Channel A)	Dc
Input Coupling (Channel B)	Gnd

**27. Check Vertical Position Range**

- a. Test equipment setup is shown in Fig. 5-43.
- b. Turn the VERT POSITION control fully counterclockwise.
- c. With the DC OFFSET control, position the trace at the bottom graticule line.
- d. With the VERT POSITION control, move the trace up exactly 5 cm on the graticule.
- e. With the DC OFFSET control, reposition the trace at the bottom graticule line.
- f. Turn the VERT POSITION control fully clockwise.
- g. Check that the trace moves upward more than 5 cm, for a total of more than 10 cm in the two steps.  
(For a 4-cm crt, the VERT POSITION control range can be checked in 3 steps of 3 cm, 3 cm and 4 cm.)

**28. Check DC Offset Range**

- a. Connect the 10X test probe to the test oscilloscope vertical input connector.
- b. Adjust the test oscilloscope trace for a zero-volt dc reference level.
- c. Touch the tip of the probe to the Type 1S1 OFFSET OUTPUT jack.
- d. Adjust the Type 1S1 DC OFFSET control to position the test oscilloscope trace at its horizontal centerline.
- e. Remove the test probe from the OFFSET OUTPUT jack.
- f. With the Type 1S1 VERT POSITION control, position the indicator oscilloscope trace to the top graticule line.
- g. Turn the Type 1S1 DC OFFSET control to the counterclockwise end of its 10-turn range.
- h. Check that the trace moves downward more than 5 cm on the graticule (representing more than -1.0-volt offset).
- i. Touch the test probe to the Type 1S1 OFFSET OUTPUT jack.
- j. With the Type 1S1 DC OFFSET control, return the test oscilloscope trace to its zero-volt dc reference level.
- k. Remove the test probe from the OFFSET OUTPUT jack.
- l. With the Type 1S1 VERT POSITION control, position the indicator oscilloscope trace to the bottom graticule line.
- m. Turn the DC OFFSET control to the clockwise end of its 10-turn range.
- n. Check that the trace moves upward more than 5 cm on the graticule (representing more than +1.0-volt offset).

**NOTES**

---

---

---

---

---

---

---

---

---

---

---

---

---

---

---

---

---

---

---

---

---

---

---

---

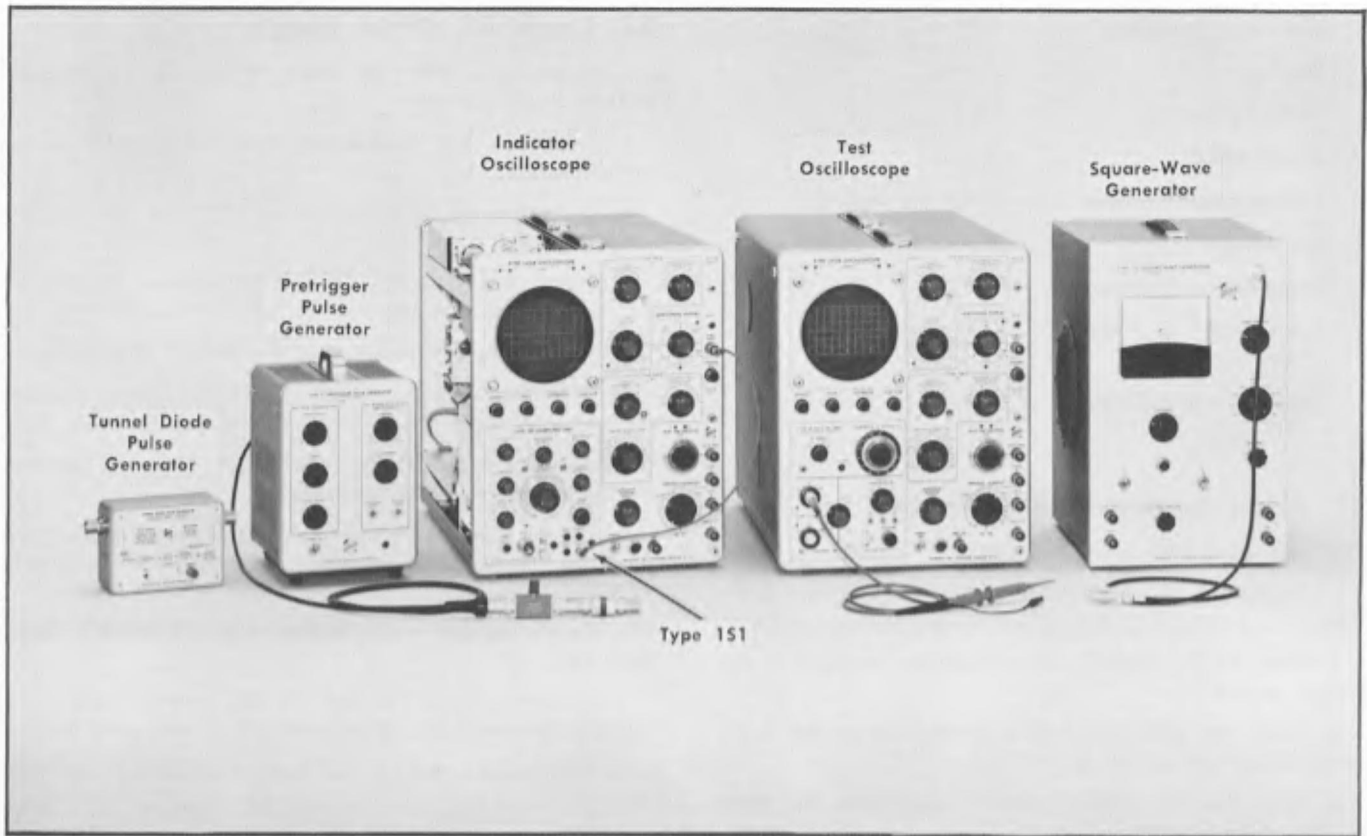

Fig. 5-44. Initial test equipment setup for steps 29 through 32.

<b>Type 151</b>	
mVOLTS/CM	200
mVolts/Cm VARIABLE	CAL
<b>VERT POSITION</b>	<b>Centered</b>
<b>DC OFFSET</b>	<b>Centered trace</b>
TIME POSITION	Centered
FINE	Centered
SMOOTHING	NORM (Clockwise)
SAMPLES/CM	Normal display
DISPLAY MODE	NORMAL
MANUAL SCAN	
EXT HORIZ ATTEN	Clockwise
<b>TIME/CM</b>	<b>5 nSEC</b>
Time/Cm VARIABLE	CAL
TRIGGER SOURCE	INT +
TRIGGER SENSITIVITY	Clockwise
RECOVERY TIME	Centered

<b>Indicator Oscilloscope</b>	
Stability (both time bases)	Counterclockwise (not Preset)
Horizontal Display	Ext Horiz Input
Intensity	Normal brightness
Amplitude Calibrator	Off
Crt Cathode Selector	Chopped Blanking

<b>Test Oscilloscope</b>	
Horizontal Display	A
Time Base A controls:	
Trigger Slope	Int +
Triggering Mode	Ac
Stability	Clockwise
Triggering Level	Clockwise
<b>Time/Cm</b>	<b>5 μsec</b>
Time/Cm Variable	Calibrated (at detent)
Time Base B Stability	Counterclockwise (not Preset)



Amplitude Calibrator	Off
Display	A—Vc
<b>Millivolts/Cm</b>	<b>2</b>
<b>Input Atten</b>	<b>1</b>
Millivolts/Cm Variable	Calib (at detent)
Vc Range	0
Comparison Voltage	6.000
Input Coupling (Channel A)	Dc
Input Coupling (Channel B)	Gnd

**Pretrigger Pulse Generator**

Repetition Rate	Centered
Range	10 Kc
Output Polarity	+

**29. Check Risetime**

(This check was made during the adjustment procedure and should be omitted here if a complete calibration procedure is being performed).

- a. Test equipment setup is shown in Fig. 5-44.
- b. Reset the Type 1S1 controls:

TIME POSITION	Clockwise
TRIGGER SOURCE	—INT

c. Perform steps 20b through 20j in the adjustment procedure to check for a risetime of 350 psec or less.

d. Disconnect the tunnel diode pulse generator from the Type 1S1 SIGNAL IN connector and turn off the generator.

e. Set the mVolts/Cm VARIABLE control to CAL position.

**30. Check Loop Gain**

(This check was made during the adjustment procedure and should be omitted here if a complete calibration procedure is being performed.)

- a. Reset instrument controls as given under Fig. 5-29.
- b. Adjust the pretrigger pulse generator repetition rate to one-half the repetition rate of the free-running trigger circuit, with the RECOVERY TIME control centered, as described in steps 18b through 18i. (If the setting of the pretrigger pulse generator Repetition Rate control was recorded in step 18, set the control to that position and omit steps 18b through 18i.)

c. Perform steps 18j through 18u of the adjustment procedure to check for unity loop gain.

**31. Check Smoothing Control**

a. Connect the pretrigger pulse generator signal to the Type 1S1 SIGNAL IN connector as in step 30.

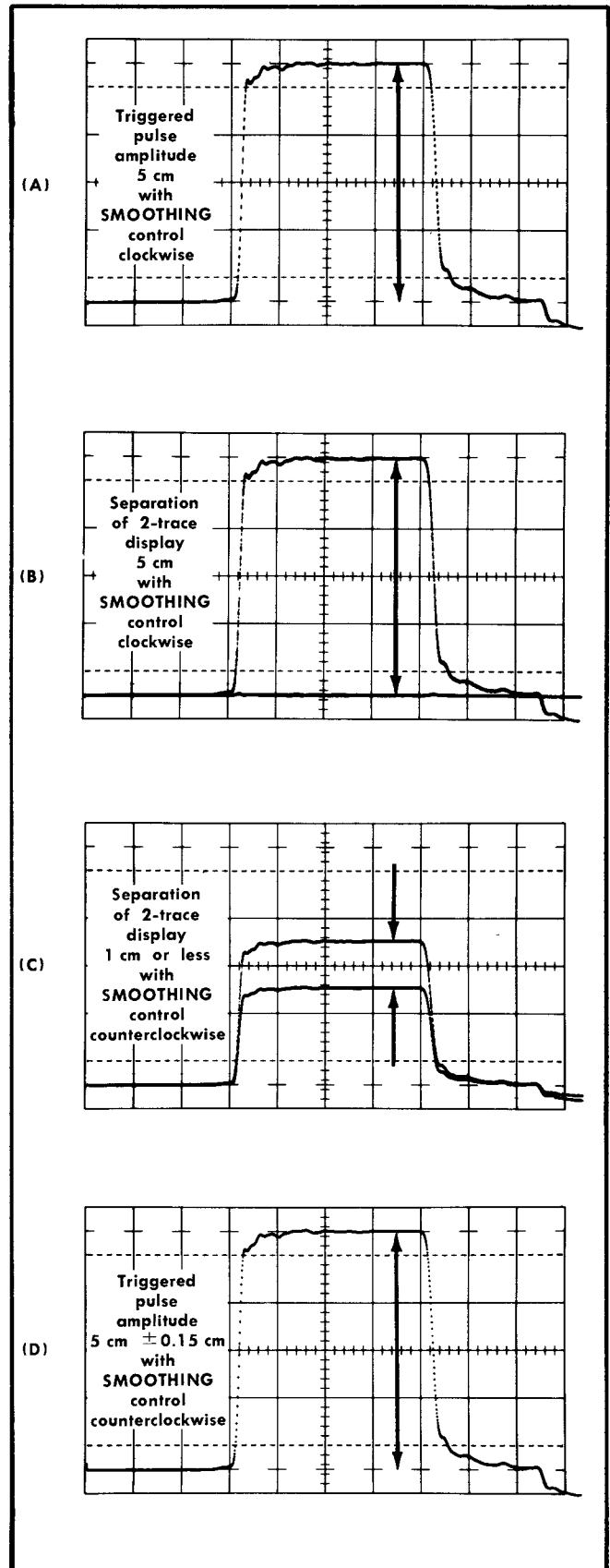

Fig. 5-45. Typical indicator oscilloscope displays for checking the SMOOTHING control.

## Calibration—Type 1S1

b. If step 30 was omitted, reset the Type 1S1 controls as follows:

TIME/CM	5 nSEC
TRIGGER SOURCE	INT +
TRIGGER SENSITIVITY	Clockwise

c. Obtain a 2-trace display of the pretrigger pulse generator 20-nsec 1-volt pulse as described in steps 18j through 18u.

d. Trigger the display (1-trace) with the Type 1S1 TRIGGER SENSITIVITY control.

e. Adjust the variable attenuator for exactly 5 cm of deflection at the flat portion of the pulse top. (See Fig. 5-45A).

f. Position the base of the pulse 2 cm below the graticule horizontal centerline.

g. Set the TRIGGER SENSITIVITY and RECOVERY TIME controls for a 2-trace display. (See Fig. 5-45B.)

h. Turn the SMOOTHING control fully counterclockwise.

i. Check for a SMOOTHING control range of 3:1 as indicated by a vertical distance of 1 cm or less between the two displayed traces. (See Fig. 5-45C.) (Between samples, the vertical correction is only  $\frac{1}{3}$ , or less, the amount of correction provided with unity loop gain.)

j. Trigger the display with the TRIGGER SENSITIVITY control.

k. Check the displayed pulse for an amplitude of 5 cm  $\pm 0.15$  cm with the SMOOTHING control fully counterclockwise (See Fig. 5-45D).

l. Disconnect the pretrigger pulse generator signal.

d. Adjust the square-wave output amplitude for a display amplitude of 5 cm.

e. Adjust the TIME POSITION control to position a rising portion of the waveform between the 2-cm and 3-cm graticule lines.

f. Set the mVOLTS/CM switch to 20.

g. With the DC OFFSET control, position the flat top of the waveform at the horizontal centerline (see Fig. 5-46B).

h. Check that there is no more than 1.5 cm (3%) of droop (tilt) following the leading edge.

i. Disconnect the coax cable and attenuator from the square-wave generator and from the Type 1S1 SIGNAL IN connector.

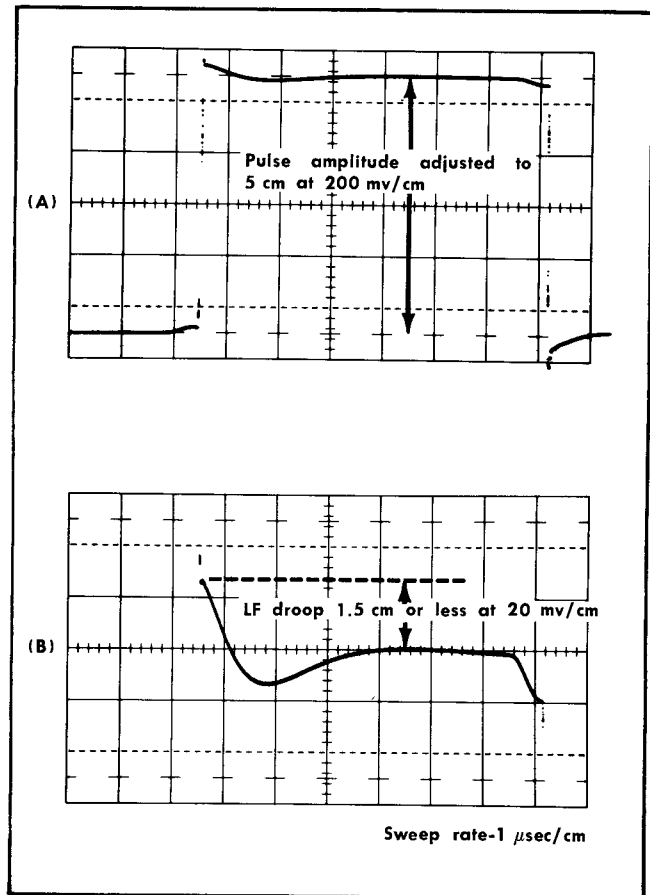

Fig. 5-46. Typical indicator oscilloscope displays for checking low-frequency droop.

## 32. Check Low-Frequency Response

a. Connect the square-wave generator through a coax cable, an adapter, and a 5X attenuator to the Type 1S1 SIGNAL IN connector.

b. Set the square-wave generator output frequency to about 150 kc.

c. Reset the following Type 1S1 controls:

TIME/CM	.5 μSEC
SMOOTHING	NORM (Clockwise)
TRIGGER SOURCE	INT—



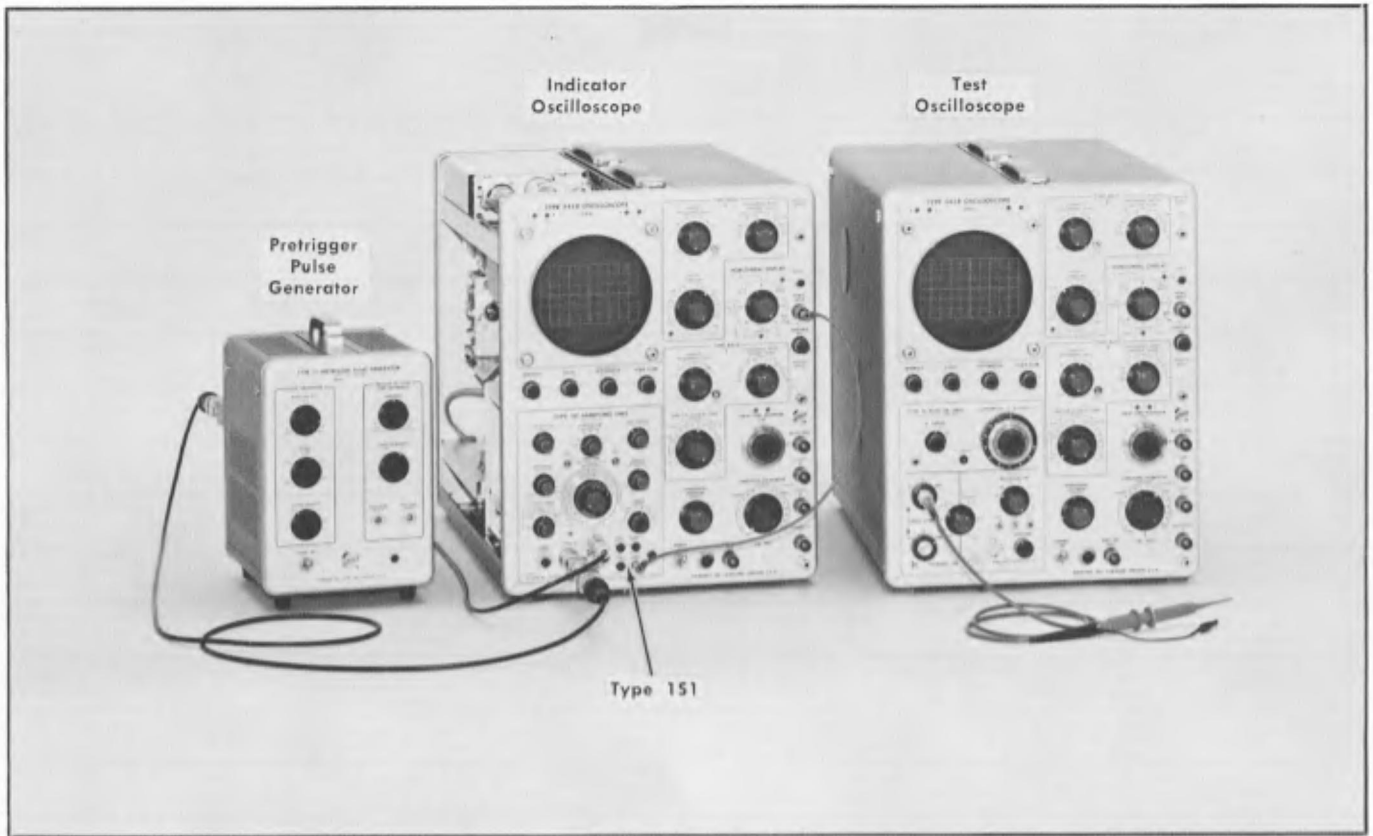

Fig. 5-47. Initial test equipment setup for steps 33 through 35.

<b>Type 151</b>		<b>Indicator Oscilloscope</b>	
<b>mVOLTS/CM</b>	<b>2</b>	Stability (both time bases)	Counterclockwise (not Preset)
mVolts/Cm VARIABLE	CAL	Horizontal Display	Ext Horiz Input
VERT POSITION	Centered	Intensity	Normal Brightness
DC OFFSET	Centered	Amplitude Calibrator	Off
<b>TIME POSITION</b>	<b>Centered</b>	Crt Cathode Selector	Chopped Blanking
<b>FINE</b>	<b>Centered</b>	<b>Test Oscilloscope</b>	
SMOOTHING	NORM (Clockwise)	Horizontal Display	A
SAMPLES/CM	Normal Display	Time Base A Controls:	
DISPLAY MODE	NORMAL	Trigger Slope	Int +
MANUAL SCAN		Triggering Mode	Ac
EXT HORIZ ATTEN	Clockwise	<b>Stability</b>	<b>Clockwise</b>
<b>TIME/CM</b>	<b>10 nSEC</b>	<b>Triggering Level</b>	<b>Clockwise</b>
Time/Cm VARIABLE	CAL	Time/Cm	5 $\mu$ Sec
<b>TRIGGER SOURCE</b>	<b>EXT +</b>	Time/Cm Variable	Calibrated (at detent)
<b>TRIGGER SENSITIVITY</b>	<b>Clockwise</b>	Time Base B Stability	Counterclockwise (not Preset)
RECOVERY TIME	Centered		

Amplitude Calibrator	Off
Display	A—Vc
<b>Millivolts/Cm</b>	<b>10</b>
<b>Input Atten</b>	<b>1</b>
Millivolts/Cm Variable	Calib (at detent)
Vc Range	0
Comparison Voltage	6.000
<b>Input Coupling (Channel A)</b>	<b>Dc</b>
Input Coupling (Channel B)	Gnd
<b>Pretrigger Pulse Generator</b>	
<b>Repetition Rate</b>	<b>Clockwise</b>
Range	10 Kc
Output Polarity	+
<b>Variable</b>	<b>Centered</b>

### 33. Check Tangential Noise

- Test equipment setup is shown in Fig. 5-47.
- Connect the pretrigger pulse generator Pulse and Pretrigger Output signals to the Type 1S1 as indicated in Fig. 5-48.
- Set the variable attenuator control to midrange.
- Trigger the trace with the TRIGGER SENSITIVITY control.

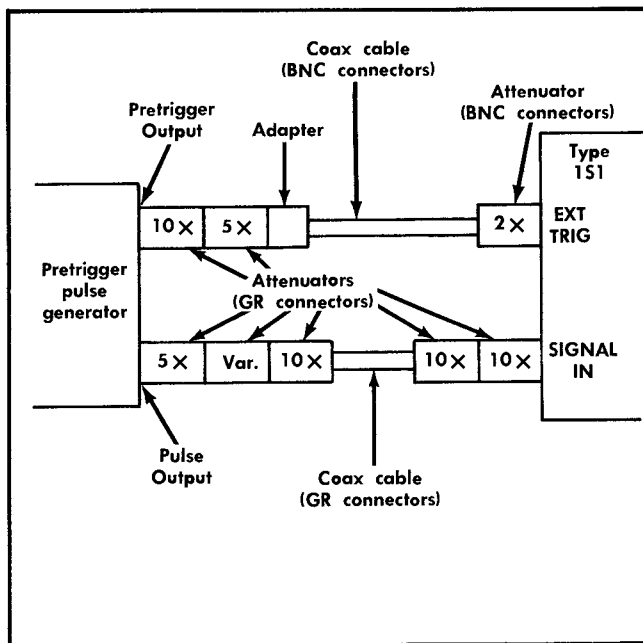

Fig. 5-48. Connections for applying pretrigger pulse generator outputs to Type 1S1 for tangential noise check.

e. Position the pulse display on the crt screen with the pretrigger pulse generator Variable control and the Type 1S1 TIME POSITION and FINE controls.

f. Adjust the variable attenuator and the Type 1S1 VERT POSITION controls to obtain a display similar to that shown in Fig. 5-49A. Approximately 10% of the display dots should

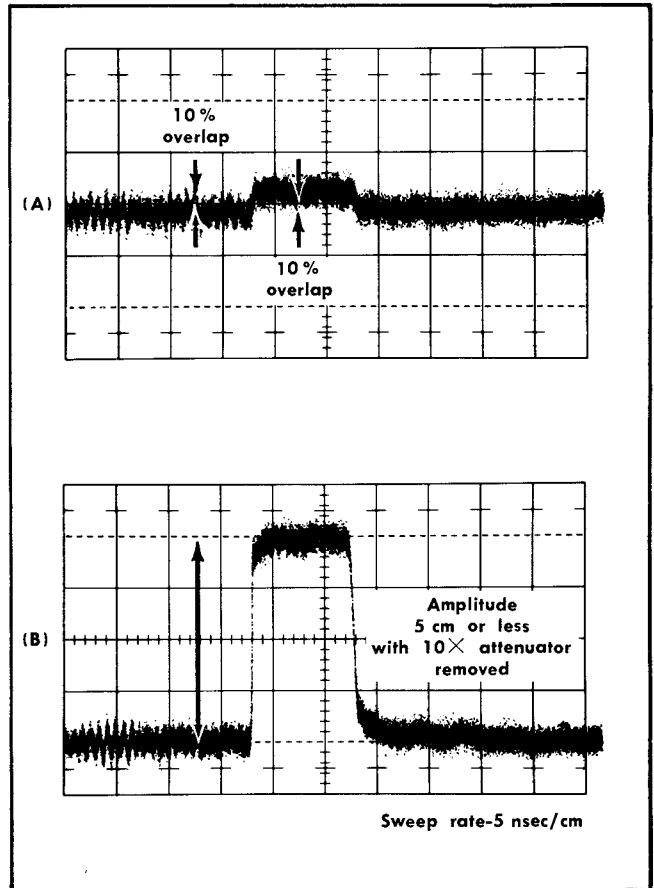

Fig. 5-49. Typical indicator oscilloscope displays for setting up and measuring tangential noise amplitude.

overlap the graticule centerline. (Effective trace width in sampling is considered to be the width containing approximately 80% of the displayed dots.) This adjustment makes the pulse amplitude equal to the noise amplitude (tangential sensitivity).

g. Leaving the variable attenuator at this setting, remove one of the 10X attenuators from the vertical signal path.

h. Check that the display amplitude is 5 cm or less with the attenuator removed (Fig. 5-49B), indicating a noise amplitude of 1 mv or less.

### 34. Check Baseline Shift

a. Disconnect the pulse signal from the SIGNAL IN connector, but leave the triggering signal connected to the Type 1S1 EXT TRIG connector.

## Calibration—Type 1S1

b. Set the pretrigger pulse generator Repetition Rate control fully clockwise (approximately 100 kc).

c. Position the triggered trace at the horizontal centerline.

d. Slowly decrease the repetition rate of the pulse generator to approximately 20 kc (Repetition Rate control set approximately 60° clockwise from center).

e. Check that the trace position does not move vertically by more than  $\pm 2$  cm ( $\pm 4$  mv) during this decrease in repetition rate.

f. Reposition the trace to the graticule centerline.

g. With the pulse generator Range switch and Repetition Rate control, decrease the repetition rate from 20 kc to approximately 30 cps (Repetition Rate control approximately centered on the 10 Cps range).

h. Check that the trace position does not shift vertically by more than  $\pm 2$  cm ( $\pm 4$  mv) during this decrease in repetition rate.

### 35. Check Memory Drift

a. Set the test oscilloscope Time/Cm switch to .1 Sec.

b. Set the Type 1S1 mVOLTS/CM switch to 200.

c. Temporarily disconnect the trigger signal cable from the attenuator on the Type 1S1 EXT TRIG connector.

d. Touch the tip of the test probe to the center conductor of the trigger cable.

e. Trigger the test oscilloscope display. It will be necessary to position the bright trace off-screen at the bottom of the crt and increase the test oscilloscope intensity to observe the narrow trigger pulses.

f. Adjust the pretrigger pulse generator Repetition Rate control for 1 pulse/cm in the test oscilloscope display (see Fig. 5-50). This sets the repetition rate at 10 cps.

g. Reconnect the trigger cable to the attenuator on the Type 1S1 EXT TRIG connector.

h. Turn the SAMPLES/CM control to MIN position (fully clockwise).

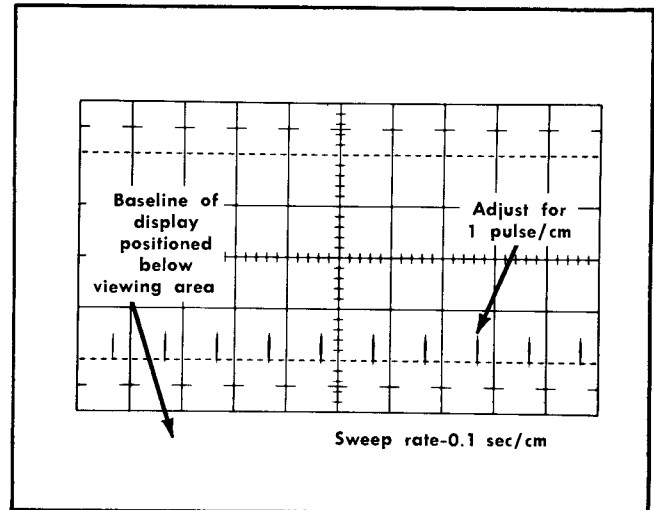

Fig. 5-50. Test oscilloscope display for setting triggering pulse repetition rate to 10 cps.

i. Check the trace for vertical drift (dot slash) of 1 cm or less (see Fig. 5-51).

j. Disconnect the pretrigger pulse generator signal from the Type 1S1 EXT TRIG connector.

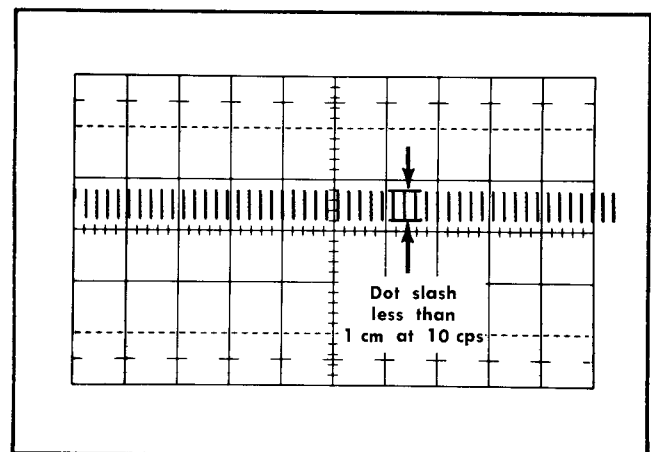

Fig. 5-51. Typical indicator oscilloscope display for checking memory drift. (Photograph is a timed exposure of a single sweep.)



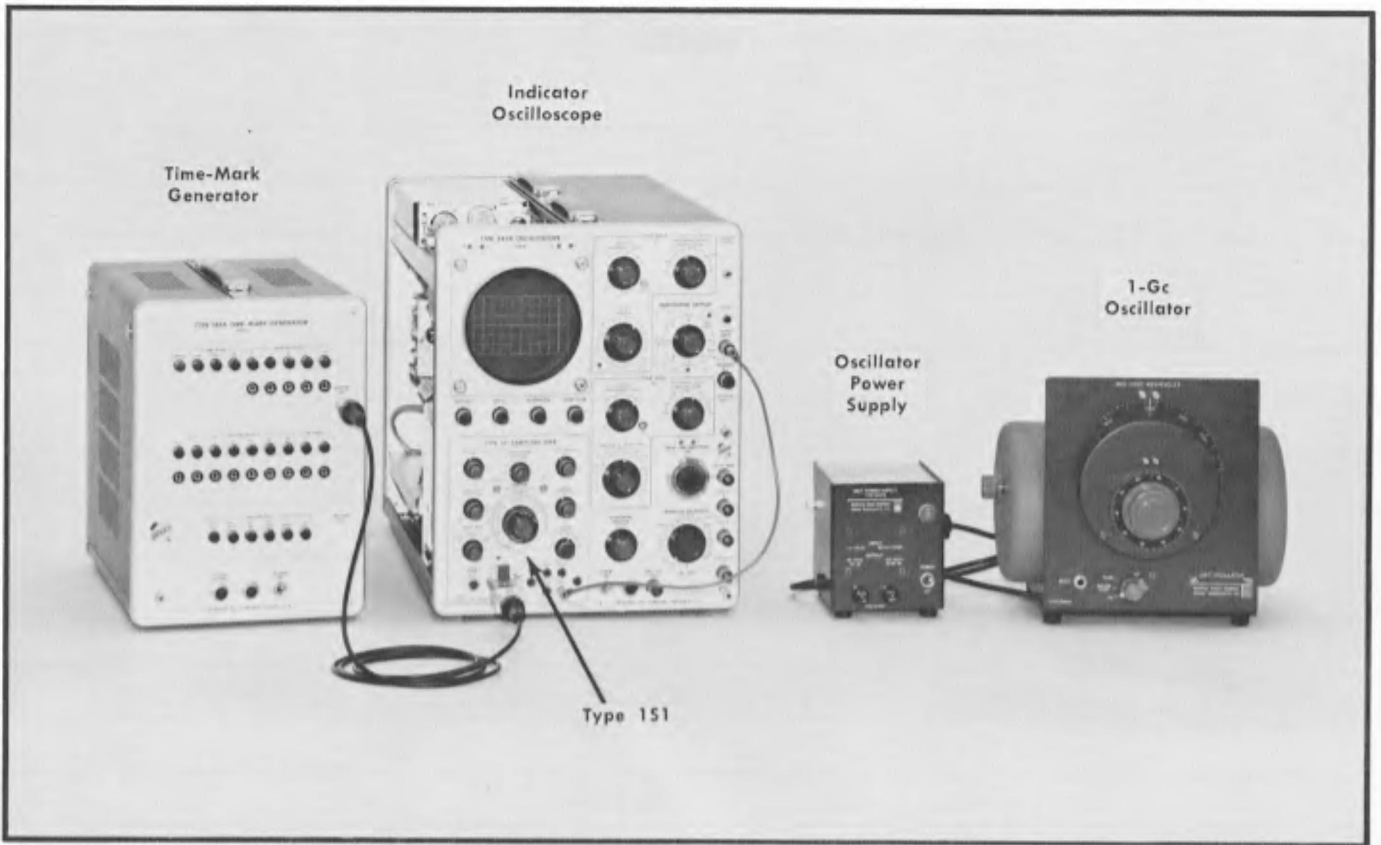

Fig. 5-52. Initial test equipment setup for steps 36 through 40.

Type 151	
mVOLTS/CM	200
mVolts/Cm VARIABLE	CAL
VERT POSITION	Centered
DC OFFSET	Centered
TIME POSITION	Centered
FINE	Centered
SMOOTHING	NORM (Clockwise)
<b>SAMPLES/CM</b>	<b>Normal Display</b>
DISPLAY MODE	NORMAL
MANUAL SCAN	
EXT HORIZ ATTEN	Clockwise

<b>TIME/CM</b>	<b>5 μSEC</b>
Time/Cm VARIABLE	CAL
<b>TRIGGER SOURCE</b>	<b>INT +</b>
<b>TRIGGER SENSITIVITY</b>	<b>Clockwise</b>
RECOVERY TIME	Centered

Indicator Oscilloscope	
Stability (both time bases)	Counterclockwise (not Preset)
Horizontal Display	Ext Horiz Input
Intensity	Normal Brightness
Amplitude Calibrator	Off
Crt Cathode Selector	Chopped Blanking



## HORIZONTAL CHECKS

### 36. Check Timing and Linearity

Basic sweep timing is checked in this step by checking each of the 3 factors that are combined to produce the equivalent-time sweep rates: Timing on each of the 5 fast ramps; the 1-2-5 ratio of the staircase inverter; and the X10 and X100 magnifiers. By checking each of these functions to within 1%, all combinations of the functions, including magnified sweep rates, will be within 3%. On the marker displays, adjust the amplitude for approximately 2 cm of deflection and measure timing from the marker tips (see Fig. 5-53). On the sine-wave displays, adjust the amplitude for approximately 4 cm of deflection and measure timing from the points where the waveform crosses the horizontal centerline.

#### 1-2-5 Ratio

- Test equipment setup is shown in Fig. 5-52.
- Connect the time-mark generator Marker Out signal through an adapter, a coax and the variable attenuator to the Type 1S1 SIGNAL IN connector.
- Set the time-mark generator for a 5- $\mu$ sec marker output signal.

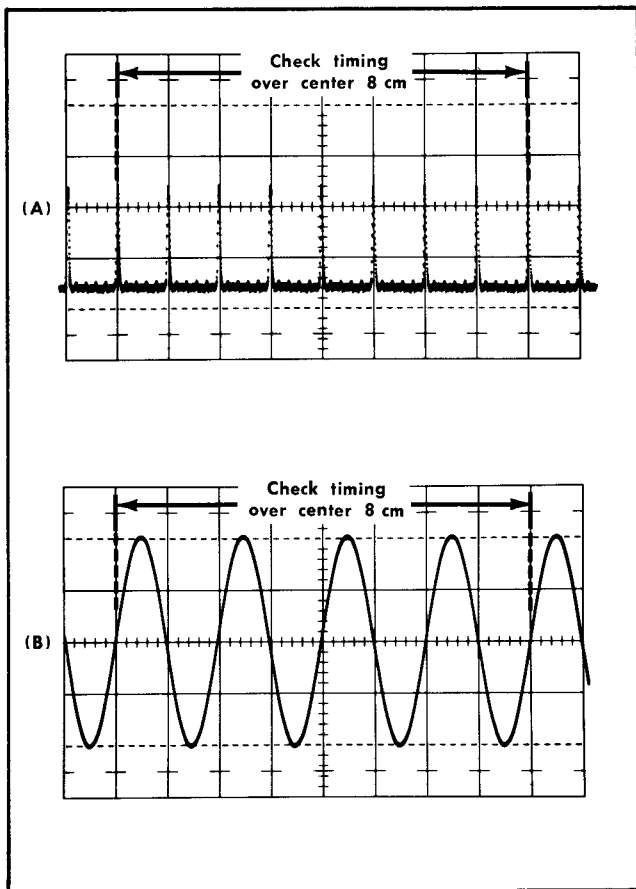

Fig. 5-53. Typical indicator oscilloscope displays for checking timing and linearity.

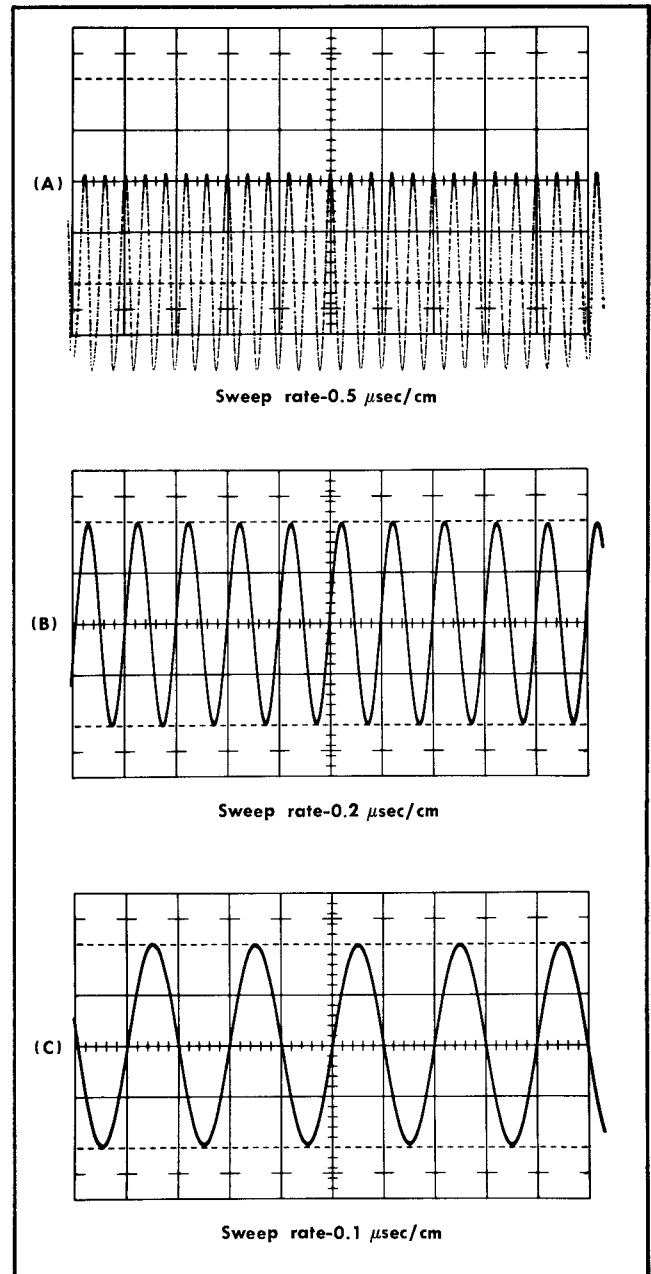

Fig. 5-54. Typical indicator oscilloscope displays for checking 1-2-5 timing ratio with a 5 Mc sine wave.

- Trigger the display with the Type 1S1 TRIGGER SENSITIVITY control.
- Adjust the variable attenuator to produce approximately 2 cm of vertical deflection.
- Adjust the SAMPLES/CM control for an adequate display of the time-mark signal.
- Check timing for 1 marker/cm over the center 8 cm of the graticule. If timing is not within 1% (0.08 cm), adjust the indicator oscilloscope Ext Horiz Input Variable control. Timing calibration was set to within 1% on this equivalent-time sweep rate during the adjustment procedure

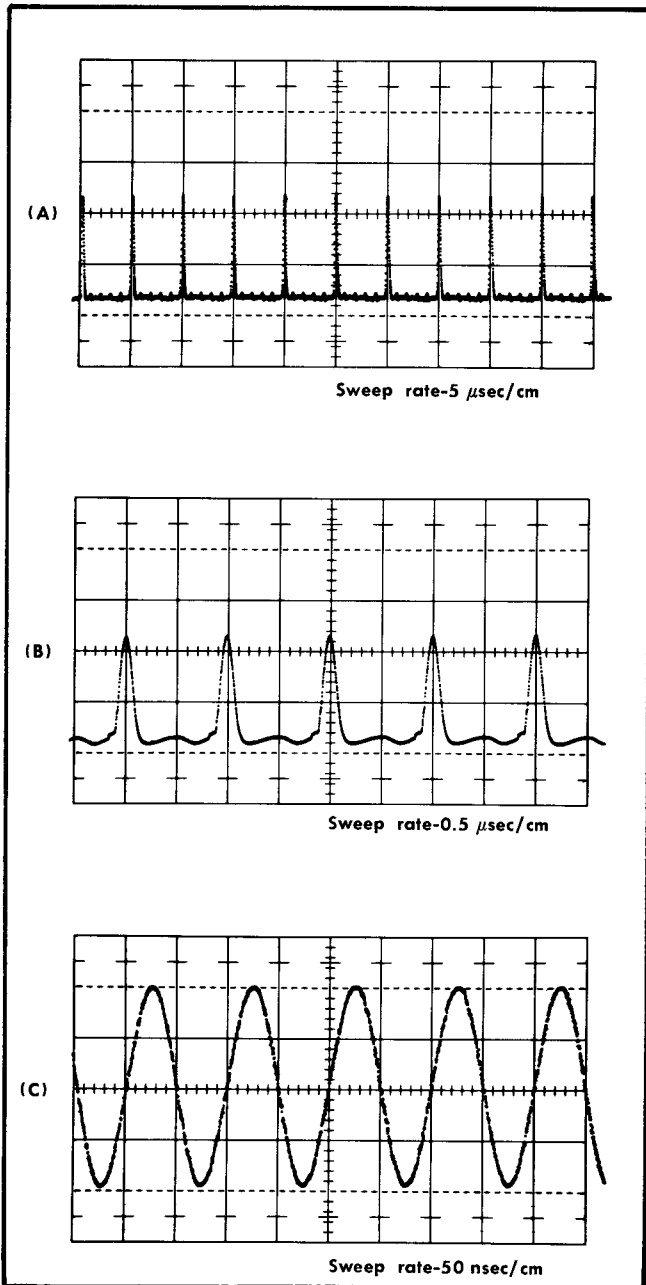

Fig. 5-55. Typical indicator oscilloscope displays for checking the  $\times 10$  and  $\times 100$  magnifiers.

(step 8). (If the adjustment procedure was not performed, check the horizontal deflection factor adjustment as described in steps 8 c through 8 l.)

- h. Set the Type 1S1 TIME/CM switch to  $.5 \mu\text{SEC}$ .
- i. Set the time-mark generator for a 5-Mc sine-wave output.
- j. Check the 1-2-5 ratio as indicated in Table 5-1 and Fig. 5-54. Timing of each sweep rate should be within 1% (0.08 cm) over the center 8 cm of the graticule, and timing of the 3 rates should be within 1% of each other.

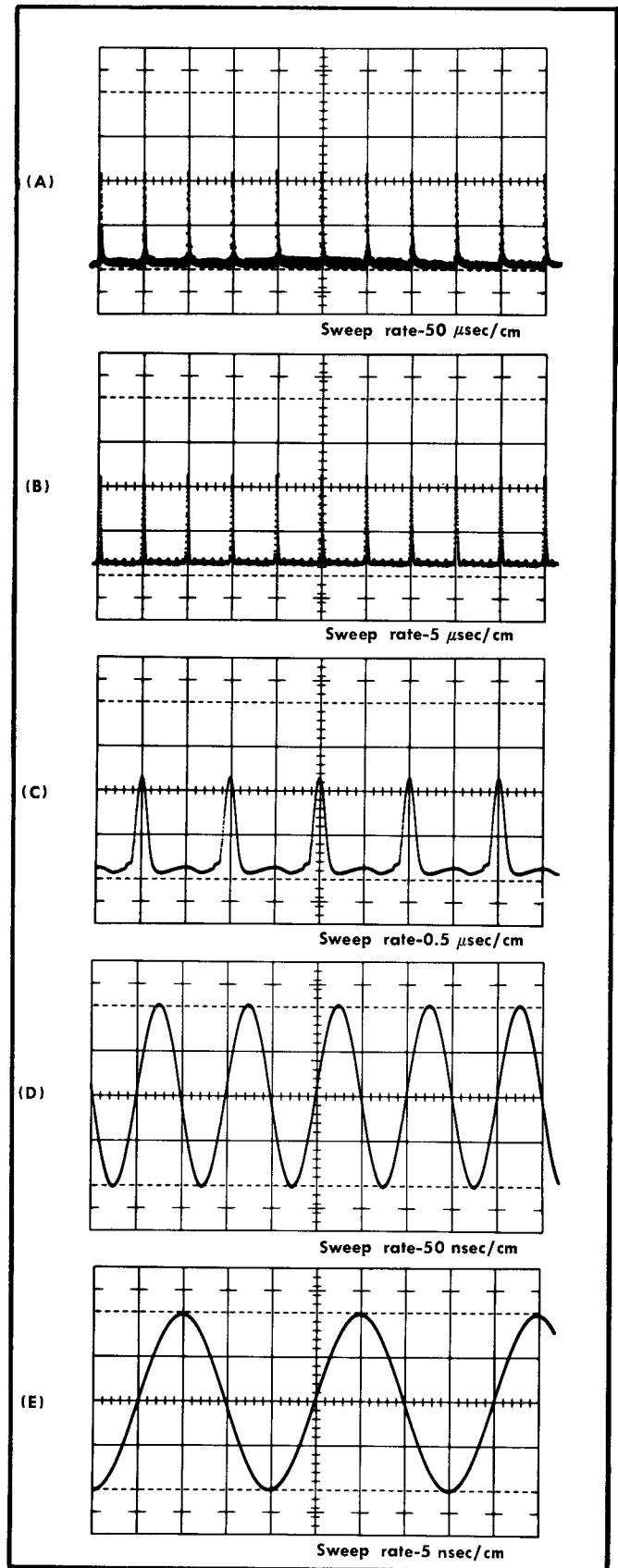

Fig. 5-56. Typical indicator oscilloscope displays for checking fast-ramp timing.

**TABLE 5-1**  
1-2-5-Ratio Check

Type 1S1 TIME/CM	Time-Mark Generator	Display
.5 $\mu$ SEC	5 Mc	5 cycles / 2 cm
.2 $\mu$ SEC	5 Mc	1 cycle / cm
.1 $\mu$ SEC	5 Mc	1 cycle / 2 cm

**X10 and X100 Attenuators**

k. Set the Type 1S1 TIME/CM switch to 5  $\mu$ SEC.

l. Check the timing (X1) as indicated in Table 5-2 at 5  $\mu$ SEC, then pull out on the MAGNIFIER knob and turn the TIME/CM switch as indicated in the table.

m. Check timing when using the X10 and X100 magnifiers as given in Table 5-2 and illustrated in Fig. 5-55. Timing over the center 8 cm should be within 1% (0.08 cm) at each magnification.

**TABLE 5-2**  
Magnifier Check

Magnification	TIME POSITION RANGE	Type 1S1 TIME/CM	Time-Mark Generator	Display
X1	50 $\mu$ S	5 $\mu$ SEC	5 $\mu$ sec	1 marker/cm
X10	50 $\mu$ S	.5 $\mu$ SEC	1 $\mu$ sec	1 marker/2 cm
X100	50 $\mu$ S	50 nSEC	10 Mc	1 cycle/2 cm

**Fast Ramp Timing**

n. Set the Type 1S1 TIME/CM switch to each position given in Table 5-3 and apply the indicated timing signal.

o. Check timing on each time position range as indicated in the table and in Fig. 5-56. Timing over the center 8 cm should be within 1% on each range.

**TABLE 5-3**  
Fast Ramp Timing

Type 1S1 TIME/CM	Time-Mark Generator	Display
50 $\mu$ SEC	50 $\mu$ sec	1 marker / cm
5 $\mu$ SEC	5 $\mu$ sec	1 marker / cm
.5 $\mu$ SEC	1 $\mu$ sec	1 marker / 2 cm
50 nSEC	10 Mc	1 cycle / 2 cm
5 nSEC	50 Mc	1 cycle / 4 cm

**Fast Ramp Linearity**

For each fast ramp (time position range), check linearity as follows:

1. Set the TIME POSITION RANGE switch to the position indicated in column 1 of Table 5-4.

2. Pull out on the MAGNIFIER knob and turn the TIME/CM switch to the position indicated in column 2.

3. Turn the TIME POSITION and FINE controls fully counterclockwise and check timing with the signal indicated in column 3. Timing should be within 3% ( $\pm 0.24$  cm over 8 cm).

4. Turn the TIME POSITION and FINE controls fully clockwise, then adjust the FINE control to remove the number of cycles indicated in column 5, and check the timing again. (The FINE control adjustment eliminates a specified amount of non-linearity at the start of the ramp.) Timing should be within 3% ( $\pm 0.24$  cm over 8 cm), and should be within 1% ( $\pm 0.08$  cm) of the measurement made with the controls turned counterclockwise.

**Optional Timing Checks**

The preceding steps have checked all sweep rates to within 3% accuracy; however, not all positions of the TIME/CM switch were included in the checks, since this was not necessary. If desired, all positions of the switch may be checked

**TABLE 5-4**  
Ramp Linearity Check

(1) TIME POSITION RANGE	(2) TIME/CM (Magnified)	(3) Timing Signal	(4) Display	(5) Delete at Clockwise Position
500 $\mu$ S	2 $\mu$ SEC	1 $\mu$ sec marker	2 markers/cm	10 nsec*
50 $\mu$ S	.2 $\mu$ SEC	5 Mc sine wave	1 cycle/cm	5 cycles
5 $\mu$ S	20 nSEC	50 Mc sine wave	1 cycle/cm	5 cycles
500 nS	1 nSEC	1 Gc sine wave	1 cycle/cm	5 cycles
50 nS	.5 nSEC	1 Gc sine wave	1 cycle/2 cm	3 cycles

\*Use 5- $\mu$ sec markers and move 4th marker 5 cm to the left, then check timing.

## Calibration—Type 1S1

as indicated in Table 5-5. Apply the timing signal from the time-mark generator or 1-Gc oscillator and check timing over the center 8 cm for accuracy within 3% ( $\pm 0.24$  cm) with the TIME POSITION and FINE controls centered.

**TABLE 5-5**

Optional Timing Checks

Type 1S1 TIME/CM	Timing Signal	Display
50 $\mu$ SEC	50 $\mu$ sec	1 marker/cm
20 $\mu$ SEC	10 $\mu$ sec	2 markers/cm
10 $\mu$ SEC	10 $\mu$ sec	1 marker/cm
5 $\mu$ SEC	5 $\mu$ sec	1 marker/cm
2 $\mu$ SEC	1 $\mu$ sec	2 markers/cm
1 $\mu$ SEC	1 $\mu$ sec	1 marker/cm
.5 $\mu$ SEC	1 $\mu$ sec	1 marker/2 cm
.2 $\mu$ SEC	5 Mc	1 cycle/cm
.1 $\mu$ SEC	10 Mc	1 cycle/cm
50 nSEC	10 Mc	1 cycle/2 cm
20 nSEC	50 Mc	1 cycle/cm
10 nSEC	50 Mc	1 cycle/2 cm
5 nSEC	50 Mc	1 cycle/4 cm
2 nSEC	1 Gc	2 cycles/cm
1 nSEC	1 Gc	1 cycle/cm
.5 nSEC	1 Gc	1 cycle/2 cm
.2 nSEC	1 Gc	1 cycle/5 cm
.1 nSEC	1 Gc	1 cycle/10 cm

### 37. Check Time/Cm Variable

- Reconnect the time-mark signal to the Type 1S1 SIGNAL IN connector.
- Reset the following Type 1S1 controls:
 

TIME/CM	1 $\mu$ SEC
TIME POSITION	Centered
FINE	Centered
- Set the time-mark generator for a 1- $\mu$ sec marker output signal.
- Trigger the display with the TRIGGER SENSITIVITY control.
- Turn the Time/Cm VARIABLE control fully clockwise.
- Check for at least 3 cm between markers, indicating a display expansion of 3:1 or greater (see Fig. 5-57).
- Return the VARIABLE control to CAL position (fully counterclockwise detent).

### 38. Check Single Sweep

- Leave the time-mark signal connected to the Type 1S1.
- With the FINE control, line up the 1- $\mu$ sec time markers on the graticule lines.

c. Set the Type 1S1 DISPLAY MODE switch to SINGLE SWEEP. After completion of the sweep, the trace will be held off.

d. Press the START button.

e. Check that a single triggered sweep occurs.

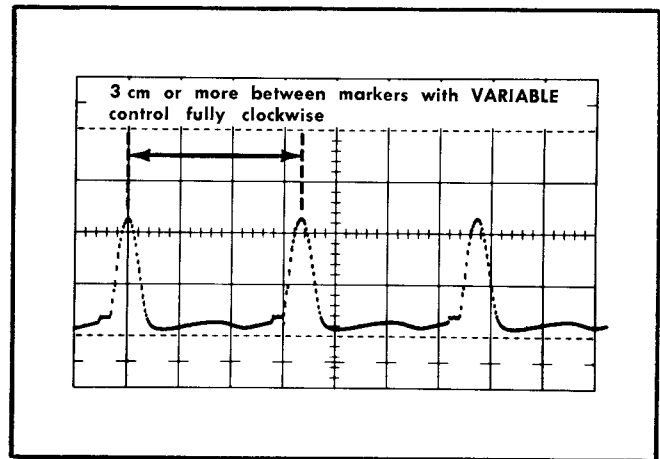

**Fig. 5-57.** Indicator oscilloscope display for checking Time/Cm VARIABLE control.

- Set the time-mark generator for no output.
- Press the START button. The sweep will remain off.
- Set the time-mark generator for 1- $\mu$ sec markers.
- Check that a single triggered sweep occurs.
- Set the DISPLAY MODE switch to NORMAL.
- Remove the time-mark signal from the Type 1S1 SIGNAL IN connector.

### 39. Check Samples/Cm

- Reset the following Type 1S1 controls:
 

TIME/CM	5 nSEC
TRIGGERED SENSITIVITY	Clockwise
SAMPLES/CM	MIN (Clockwise)
- Check the trace for a dot density of from 4 to 6 samples/cm.
- Turn the SAMPLES/CM control fully counterclockwise (not to SWEEP OFF detent position).
- Check that the displayed dot traverses the 10 cm of the crt screen in a period of time no longer than 30 sec and no shorter than 1 sec.
- Adjust the indicator oscilloscope Intensity control for a dim trace.
- Switch the SAMPLES/CM control into the SWEEP OFF position (counterclockwise detent).

### 40. Check Blanking

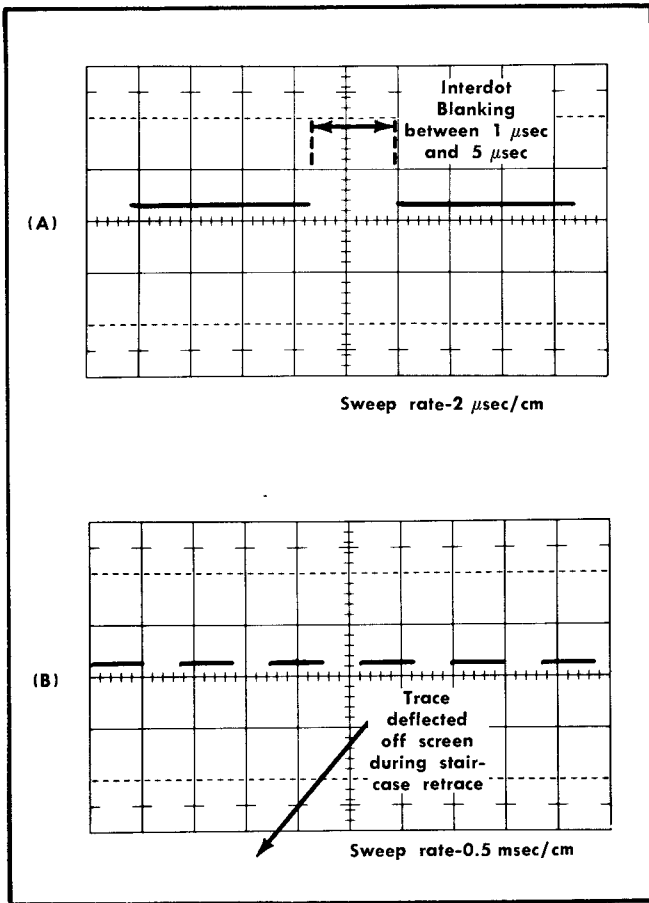

Fig. 5-58. Typical indicator oscilloscope real-time displays showing interdot and retrace blanking.

g. Check that the displayed dot remains nearly stationary on the crt screen.

h. Switch the SAMPLES/CM control out of SWEEP OFF position and set to fully clockwise.

a. Reset the following indicator oscilloscope controls:

- |                    |                      |
|--------------------|----------------------|
| Horizontal Display | A                    |
| Stability          | Clockwise (Free Run) |
| Time/Cm            | 2 μSec               |

b. With the Type 1S1 DC OFFSET control, position the free-running trace at the horizontal centerline of the indicator oscilloscope screen.

c. Position the start of the sweep at the left edge of the graticule with the indicator oscilloscope Horizontal Position control.

d. Trigger the display with the indicator oscilloscope triggering controls.

e. Check the display for blanked areas of from 1 μsec to 5 μsec (0.5 cm to 2.5 cm) between bright portions of the waveform (see Fig. 5-58A). This is interdot blanking.

f. Set the indicator oscilloscope Time/Cm switch to .5 mSec.

g. Check the display for a blanked area during the retrace portion of the Type 1S1 staircase generator cycle, similar to that shown in Fig. 5-58B.

h. Turn the Type 1S1 DC OFFSET and VERT POSITION controls fully clockwise.

i. Check that the crt beam is deflected completely out of the viewing area during retrace.

j. Set the indicator oscilloscope Horizontal Display switch to the position used previously (either Ext X1 or Ext X10). The Ext Horiz Input Variable control should still be set for a deflection factor of 1 volt/cm.

k. Set the indicator oscilloscope triggering controls to hold off the sweep generator.

l. Position the trace on the screen with Type 1S1 DC OFFSET control and the indicator oscilloscope Horizontal Position control.

### NOTES

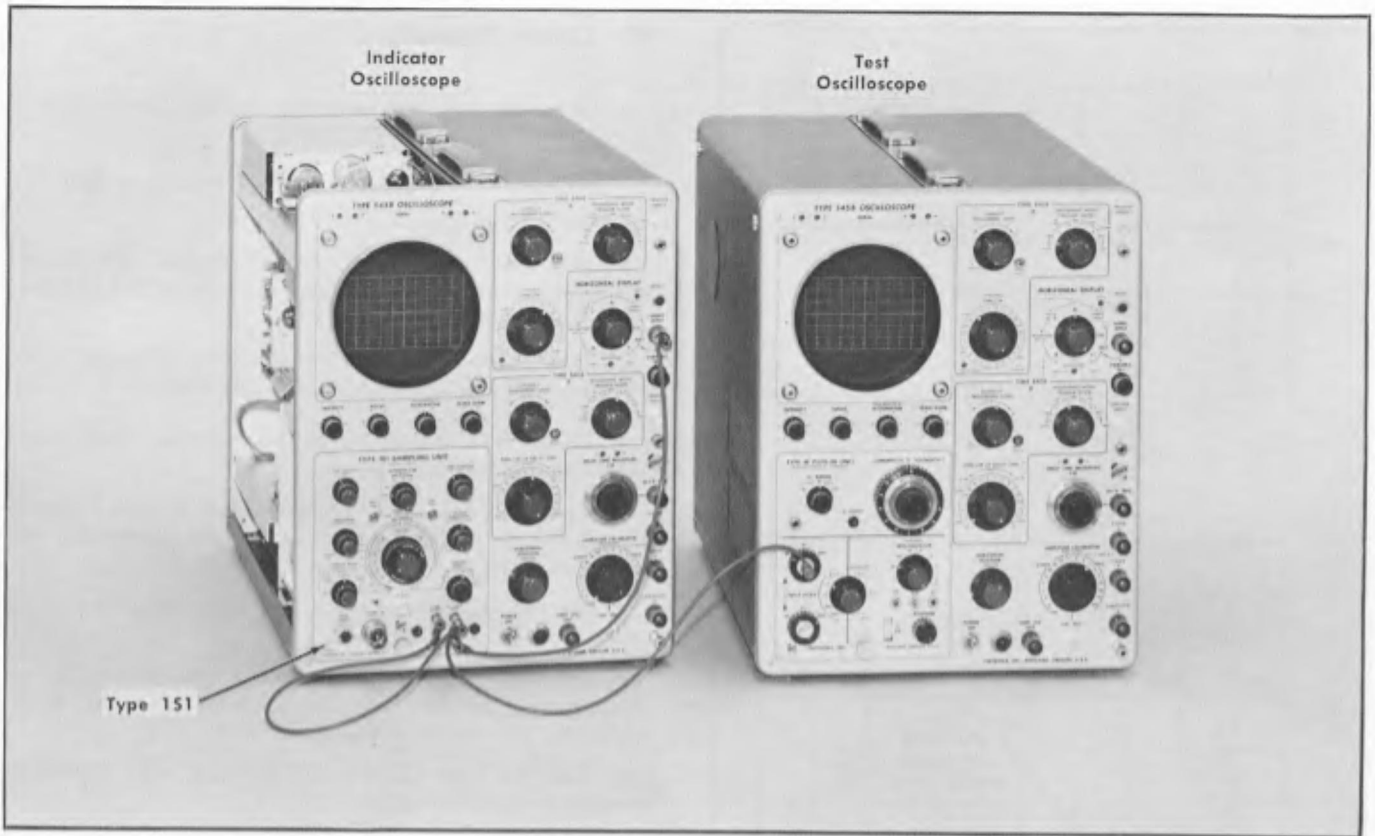

Fig. 5-59. Initial test equipment setup for step 41.

<b>Type 151</b>		<b>Indicator Oscilloscope</b>	
mVOLTS/CM	200	Stability (both time bases)	Counterclockwise (not Pre-set)
mVolts/Cm VARIABLE	CAL	Horizontal Display	Ext Horiz Input
<b>VERT POSITION</b>	<b>Centered</b>	Intensity	Normal Brightness
DC OFFSET	Centered	<b>Amplitude Calibrator</b>	<b>100 Volts</b>
TIME POSITION	Centered	Crt Cathode Selector	Chopped Blanking
FINE	Centered	<b>Test Oscilloscope</b>	
SMOOTHING	NORM (Clockwise)	Horizontal Display	A
SAMPLES/CM	Centered	Time Base A controls:	
<b>DISPLAY MODE</b>	<b>EXT HORIZ</b>	Trigger Slope	Int +
MANUAL SCAN		Triggering Mode	Ac
EXT HORIZ ATTEN	Clockwise	<b>Stability</b>	<b>Clockwise</b>
TIME/CM	5 nSEC	<b>Triggering Level</b>	<b>Clockwise</b>
Time/Cm VARIABLE	CAL	<b>Time / Cm</b>	<b>.5 mSEC</b>
TRIGGER SOURCE	INT +	Time/Cm Variable	Calibrated (at detent)
TRIGGER SENSITIVITY	Clockwise	Time Base B Stability	Counterclockwise (not Pre-set)
RECOVERY TIME	Centered		

Amplitude Calibrator	Off
Display	A—Vc
<b>Millivolts/Cm</b>	<b>50</b>
<b>Input Atten</b>	<b>R = ∞</b>
Millivolts/Cm Variable	Calib (at detent)
Vc Range	0
<b>Comparison Voltage</b>	<b>4.000</b>
<b>Input Coupling (Channel A)</b>	<b>Gnd</b>
Input Coupling (Channel B)	Gnd

#### 41. Check Ext Horiz Atten — Manual Scan

- a. Test equipment setup is shown in Fig. 5-59.
- b. Disconnect the probe from the test oscilloscope vertical input.
- c. Connect a BNC/banana patch cord from the Type 1S1 EXT HORIZ INPUT jack to the test oscilloscope vertical input.
- d. Connect a banana/banana patch cord from the OFF-SET OUTPUT jack to the jack at the Type 1S1 EXT HORIZ INPUT, as shown in Fig. 5-59. The patch cord from the Type 1S1 HORIZ OUTPUT jack to the indicator oscilloscope Ext Horiz Input jack should remain in place.
- e. Set the test oscilloscope trace for a zero-volt dc reference level.
- f. Reset the following test oscilloscope controls:
 

Vc Range	—11
Input Coupling	Dc
- g. Adjust the Type 1S1 DC OFFSET control to center the trace on the test oscilloscope crt screen.
- h. Adjust the Type 1S1 VERT POSITION control and the indicator oscilloscope Horizontal Position control to position the displayed spot on the indicator oscilloscope crt screen at the intersection of the horizontal centerline and the 1-cm vertical graticule line (see Fig. 5-60A).
- i. Set the test oscilloscope Vc Range switch to +11.
- j. Turn the DC OFFSET control counterclockwise to re- turn the test oscilloscope trace to its horizontal centerline.
- k. Turn the Type 1S1 VERT POSITION control counterclockwise to position the displayed dot at the horizontal centerline of the indicator oscilloscope crt screen.
- l. Check that the dot is now within 0.32 cm of the 9-cm graticule line (see Fig. 5-60A), representing a minimum deflection factor of 1 volt/cm  $\pm 4\%$  with the EXT HORIZ ATTEN control fully clockwise.
- m. Remove the banana/banana patch cord connected from the OFFSET OUTPUT jack to the EXT HORIZ INPUT jack. (Leave the patch cord that is connected to the oscilloscope.)

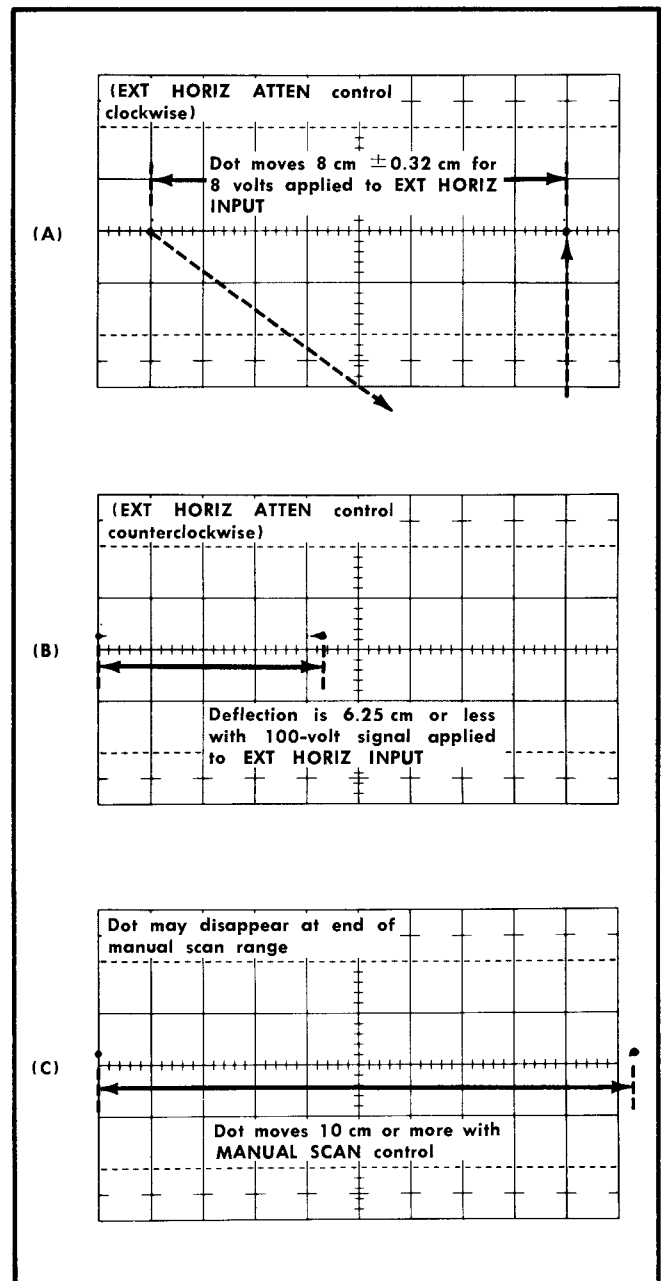

Fig. 5-60. Typical indicator oscilloscope displays for checking EXT HORIZ ATTEN control range.

- n. Disconnect the BNC patch cord connector from the test oscilloscope vertical input and connect it to the indicator oscilloscope Cal Out connector.
- o. With the indicator oscilloscope Horizontal Position control, position the displayed dot at the left edge of the indicator oscilloscope graticule.
- p. Slowly turn the Type 1S1 EXT HORIZ ATTEN control fully counterclockwise.
- q. Check that the horizontal deflection can be reduced to 6.25 cm or less, representing a maximum deflection factor of 16 volts/cm or more (see Fig. 5-60B).

## Calibration—Type 151

r. Disconnect the patch cord from the Cal Out connector and the Type 151 EXT HORIZ INPUT jack. (Leave the patch cord connected between the Type 151 HORIZ OUTPUT jack and the indicator oscilloscope Ext Horiz Input jack.

s. Set the Type 151 DISPLAY MODE switch to MAN.

t. Turn the MANUAL SCAN control fully counterclockwise.

u. With the indicator oscilloscope Horizontal Position control, position the displayed dot at the left edge of the graticule.

v. Slowly turn the MANUAL SCAN control fully clockwise.

w. Check that the displayed dot moves at least 10 cm to the right as the control is turned (see Fig. 5-60C). The dot should stop or disappear before it has moved 11 cm.

x. Reset the DISPLAY MODE switch to NORMAL.

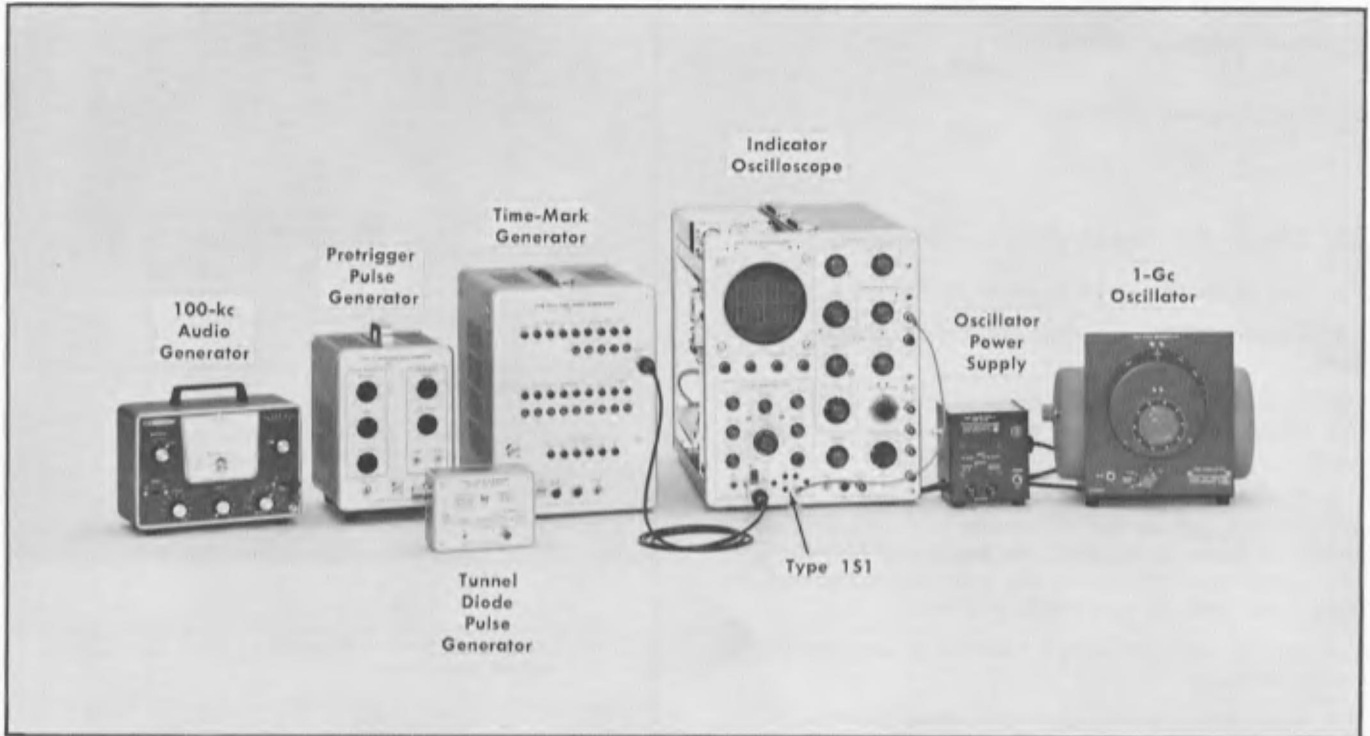

Fig. 5-61. Initial test equipment setup for steps 42 and 43.

Type 151	
mVOLTS/CM	200
mVolts/Cm VARIABLE	CAL
<b>VERT POSITION</b>	<b>Centered</b>
DC OFFSET	Centered
TIME POSITION	Centered
FINE	Centered
SMOOTHING	NORM (Clockwise)
<b>SAMPLES/CM</b>	<b>Normal Display</b>
DISPLAY MODE	NORMAL
<b>MANUAL SCAN</b>	
EXT HORIZ ATTEN	Clockwise

Indicator Oscilloscope	
<b>TIME/CM</b>	<b>10 <math>\mu</math>SEC</b>
Time/Cm VARIABLE	CAL
TRIGGER SOURCE	INT +
TRIGGER SENSITIVITY	Clockwise
RECOVERY TIME	Centered

Indicator Oscilloscope	
Stability (both time bases)	Counterclockwise (not Pre-set)
Horizontal Display	Ext Horiz Input
Intensity	Normal Brightness
<b>Amplitude Calibrator</b>	<b>Off</b>
Crt Cathode Selector	Chopped Blanking



**TABLE 5-6**  
Display Jitter Check

Signal	TRIGGER SOURCE	TIME POSITION RANGE	Setup		Readout		Jitter (Max.)
			TIME/CM (Magnified)	mVOLTS/CM	TIME/CM (Magnified)	mVOLTS/CM	
1- $\mu$ sec marker	+INT	500 $\mu$ S	.2 $\mu$ SEC	200	.1 $\mu$ SEC	50	$\leq$ 1 cm (100 nsec)
5-Mc sine wave	+INT	50 $\mu$ S	.1 $\mu$ SEC	200	10 nSEC	50	$\leq$ 1 cm (10 nsec)
5-Mc sine wave	+INT	5 $\mu$ S	.1 $\mu$ SEC	200	1 nSEC	5	$\leq$ 1 cm (1 nsec)
TD Pulse	-INT	500 nS	5 nSEC	200	.1 nSEC	20	$\leq$ 1.2 cm (120 psec)
TD Pulse	-INT	50 nS	5 nSEC	200	.1 nSEC	20	$\leq$ 0.4 cm (40 psec)

**42. Check Display Jitter**

(Display jitter is a function of both triggering jitter and fast ramp time jitter. In this check, moderate-amplitude fast-rise signals are used to minimize the triggering portion of the jitter.)

Use the following procedure on each time position range to check display jitter, as outlined in Table 5-6. The test equipment setup is shown in Fig. 5-61. During the procedure, the SAMPLES/CM control may be readjusted as necessary to speed up the display or to slow it down for a reading.

a. Connect the indicated signal from the time-mark generator or tunnel diode pulse generator. Signal amplitude must be between 400 mv and 1 volt (2 to 5 cm at 200 mv/cm), therefore the variable attenuator must be inserted for the 5 Mc signal.

b. Set the TRIG SOURCE and TIME POSITION RANGE switches as given in the table.

c. Set the mVOLTS/CM switch to 200 and magnify the display by setting the TIME/CM switch to the "setup" position, then trigger the display.

d. Advance the TIME/CM switch to the "readout" position.

e. With the TIME POSITION and FINE controls, position

the most vertical portion of the waveform between the 5-cm and 6-cm graticule lines.

f. Set the mVOLTS/CM switch to the "readout" position.

g. Check the time jitter of the display as indicated by horizontal thickness of the trace (see Fig. 5-62). Maximum jitter specifications given in the table are for properly triggered displays.

**TRIGGERING CHECKS**

**43. Check Triggering Jitter**

Use the following procedure with each of the input triggering signals given in Table 5-7. (The SAMPLES/CM control may be adjusted as required during the procedure.)

a. Connect the indicated input triggering signal to the SIGNAL IN connector and to the EXT TRIG connector through a T-connector, attenuators and coax cables as necessary (see Fig. 5-63).

b. Set the TRIG SOURCE and TIME/CM switches as indicated in the table.

c. Set the mVOLTS/CM switch to 10 to setup the triggered display. (Use SYNC triggering for the 10-Mc and 1-Gc signals; use a 100-kc repetition rate for the pulse generator signal.)

**TABLE 5-7**  
Triggering Jitter Check

Source	Signal	Connections	Setup			TRIG-GER SOURCE	Readout		Jitter (Max.)
			TIME/CM	mVOLTS/CM	Display Amplitude		TIME/CM	mVOLTS/CM	
Audio generator	100-kc sine wave	#1 Fig. 5-63	2 $\mu$ SEC	10	5 cm	+ INT	.5 $\mu$ SEC	2	1.4 cm (0.7 $\mu$ sec)
				10	5 cm	+ EXT	.5 $\mu$ SEC	2	1.0 cm (0.5 $\mu$ sec)
Time-mark generator	10-Mc sine-wave	#2 Fig. 5-63	50 nSEC	10	5 cm	+ INT	10 nSEC	2	0.5 cm (5 nsec)
				10	4 cm	+ EXT	10 nSEC	2	0.5 cm (5 nsec)
1-Gc oscillator	1-Gc sine wave	#2 Fig. 5-63	1 nSEC	10	5 cm	+ INT	.2 nSEC	2	1 cm (200 psec)
				10	4 cm	+ EXT	.2 nSEC	2	1 cm (200 psec)
Pretrigger pulse generator	2-nsec pulse (no charge line)	#3 Fig. 5-63	5 nSEC	10	4 cm	+ INT	.2 nSEC	2	1 cm (200 psec)
				10	3.5 cm	+ EXT	.2 nSEC	2	1 cm (200 psec)

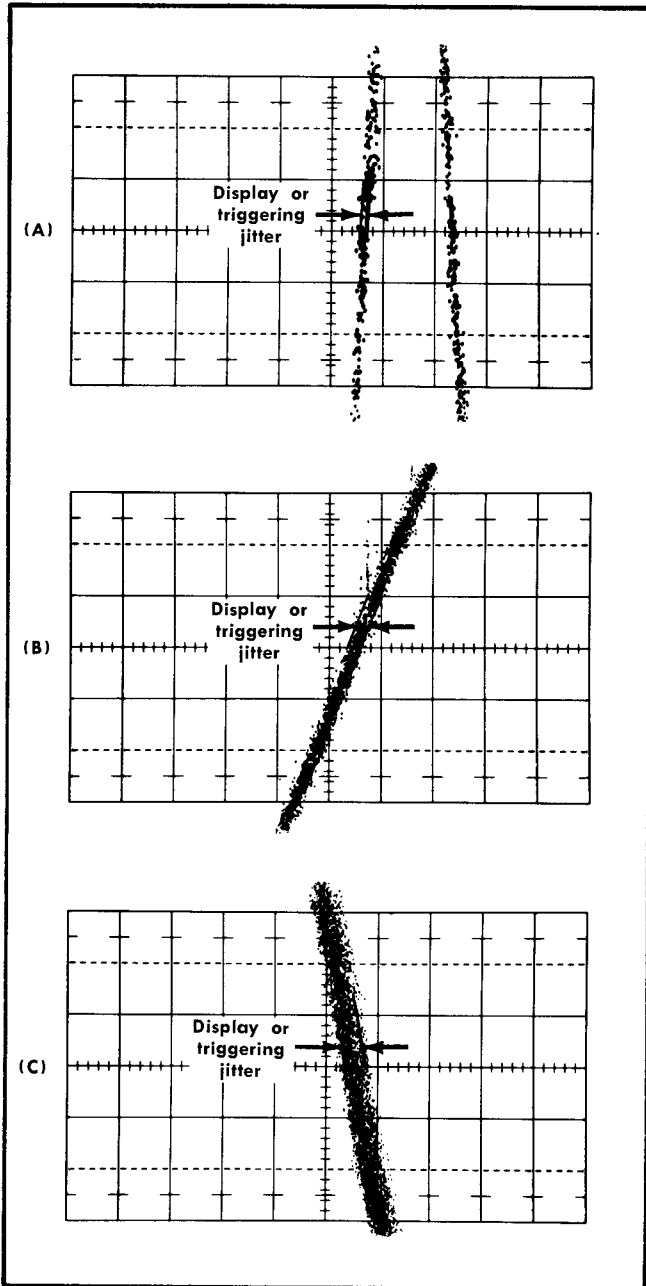

Fig. 5-62. Typical indicator oscilloscope displays for checking display or triggering jitter. Measure the effective width of the trace containing 80% of the display dots.

- d. Adjust the variable attenuator and/or signal source for the indicated display amplitude.
- e. With the TIME POSITION and FINE controls, position the most vertical portion of the waveform between the 5-cm and 6-cm graticule lines (see Fig. 5-62).
- f. Set the mVOLTS/CM switch to the "readout" position in the table.
- g. Check the time jitter of the waveform as indicated by horizontal thickness of the trace. Maximum jitter specifications for properly triggered displays are given in the table.
- h. After completing all the checks, disconnect the attenuators, cables and connectors.

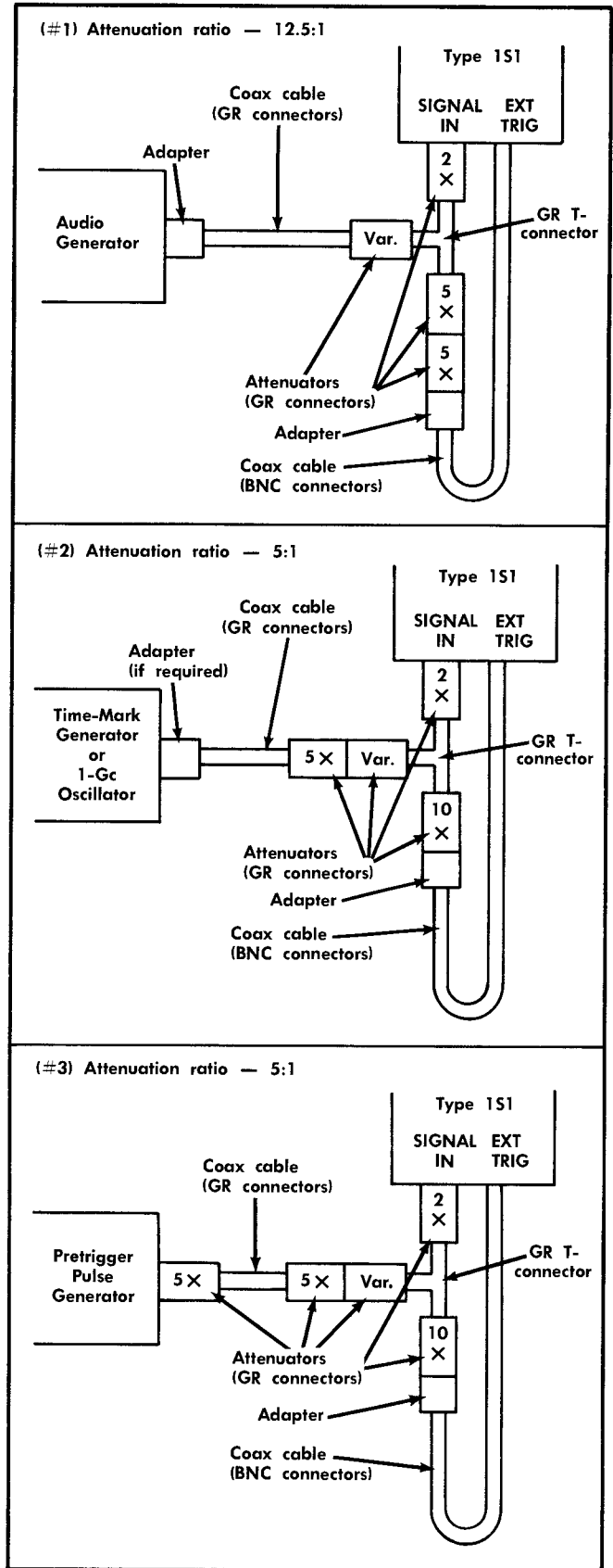

Fig. 5-63. Suggested connections for checking triggering jitter.

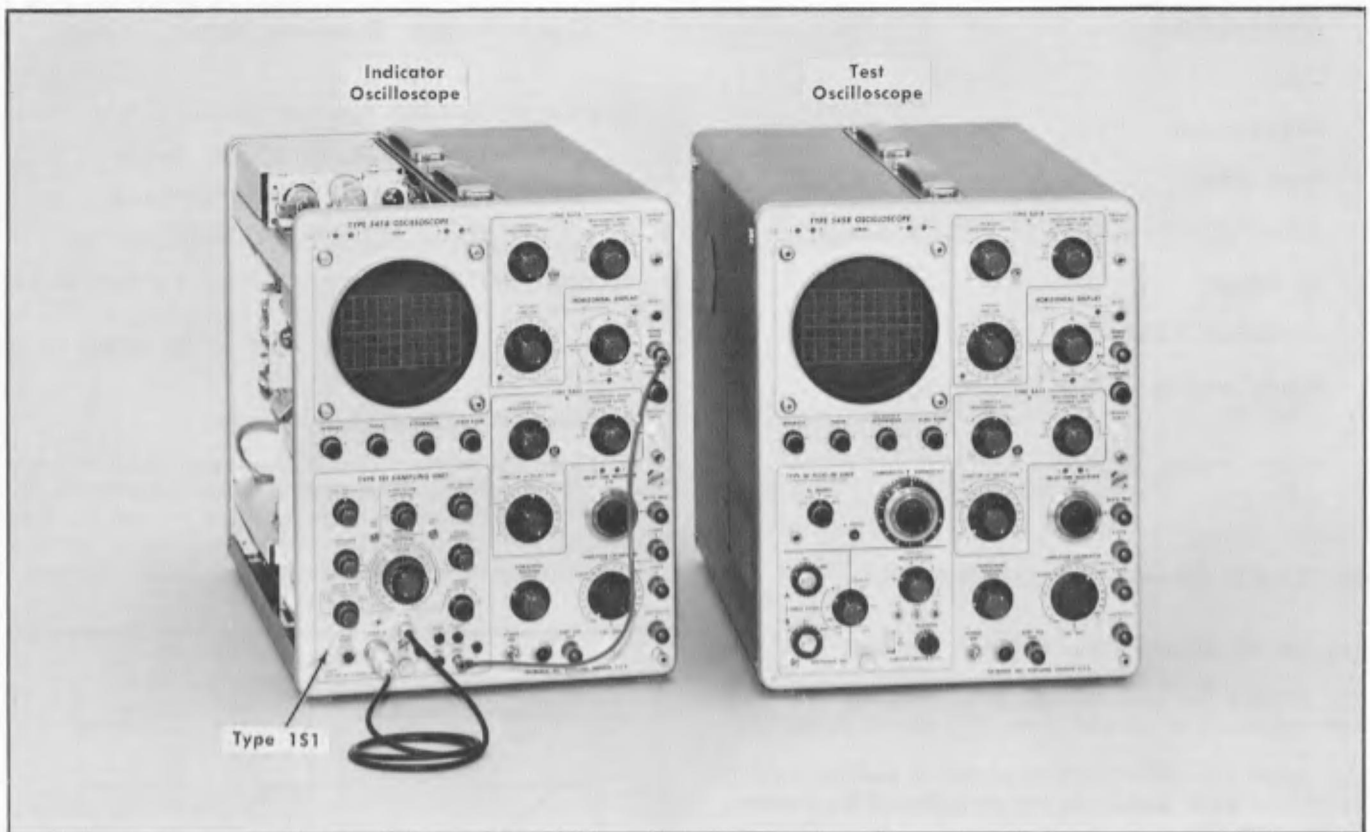

Fig. 5-64. Initial test equipment setup for steps 44 and 45.

**Type 151**

<b>mVOLTS/CM</b>	<b>10</b>
mVolts/Cm VARIABLE	CAL
VERT POSITION	Centered
DC OFFSET	Centered
<b>TIME POSITION</b>	<b>Centered</b>
<b>FINE</b>	<b>Centered</b>
SMOOTHING	NORM (Clockwise)
SAMPLES/CM	Normal display
DISPLAY MODE	NORMAL
MANUAL SCAN	
EXT HORIZ ATTEN	Clockwise
<b>TIME/CM</b>	<b>2 nSEC</b>
Time/Cm VARIABLE	CAL
<b>TRIGGER SOURCE</b>	<b>EXT +</b>
<b>TRIGGER SENSITIVITY</b>	<b>Clockwise</b>
<b>RECOVERY TIME</b>	<b>Counterclockwise (not at SYNC)</b>

**Indicator Oscilloscope**

Stability (both time bases)	Counterclockwise (not Pre-set)
Horizontal Display	Ext Horiz Input
Intensity	Normal Brightness
Amplitude Calibrator	Off
Crt Cathode Selector	Chopped Blanking

**Test Oscilloscope**

Horizontal Display	A
Time Base A controls:	
Trigger Slope	Int +
Triggering Mode	Ac
<b>Stability</b>	<b>Clockwise</b>
<b>Triggering Level</b>	<b>Clockwise</b>
<b>Time/Cm</b>	<b>2 μSec</b>
Time/Cm Variable	Calibrated (at detent)
Time Base B Stability	Counterclockwise (not Pre-set)

## Calibration—Type 1S1

Amplitude Calibrator	Off
Display	A—Vc
<b>Millivolts/Cm</b>	<b>5</b>
<b>Input Atten</b>	<b>1</b>
Millivolts/Cm Variable	Calib (at detent)
<b>Vc Range</b>	<b>0</b>
Comparison Voltage	4.000
<b>Input Coupling (Channel A)</b>	<b>Ac</b>
Input Coupling (Channel B)	Gnd

### 44. Check External Trigger Kickout

- Test equipment setup is shown in Fig. 5-64.
- Connect the Type 1S1 EXT TRIG connector through a coax cable and an adapter to the SIGNAL IN connector.
- Adjust the TIME POSITION control to position the trigger kickout pulse display on the crt screen of the indicator oscilloscope.
- Check the display for 25 mv (2.5 cm) or less of trigger kickout (see Fig. 5-65).

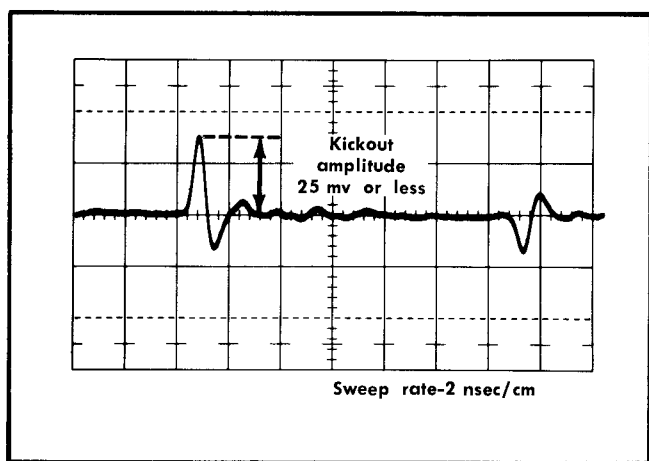

Fig. 5-65. Typical indicator oscilloscope display for checking external trigger kickout.

- Set the Type 1S1 TRIGGER SOURCE switch to EXT —.
- Check the display for 25 mv or less of trigger kickout.
- Disconnect the coax cable and adapter.

### 45. Check Trigger Recovery Time

- Reset the following Type 1S1 controls:
 

DISPLAY MODE	SINGLE SWEEP
SAMPLES/CM	MIN (Clockwise)
- Set the TRIGGER SOURCE switch to EXT +.
- Install the 10X probe on the vertical input of the test oscilloscope.
- Connect the test probe to the Type 1S1 HORIZ OUTPUT jack.
- Trigger the test oscilloscope display.
- Check the recovery time of the trigger circuit for each time position range, as indicated in Table 5-8, with the RECOVERY TIME control set for minimum holdoff (counterclockwise, but not at SYNC). The recovery time is the time between cycles of the waveform (see Fig. 5-66).

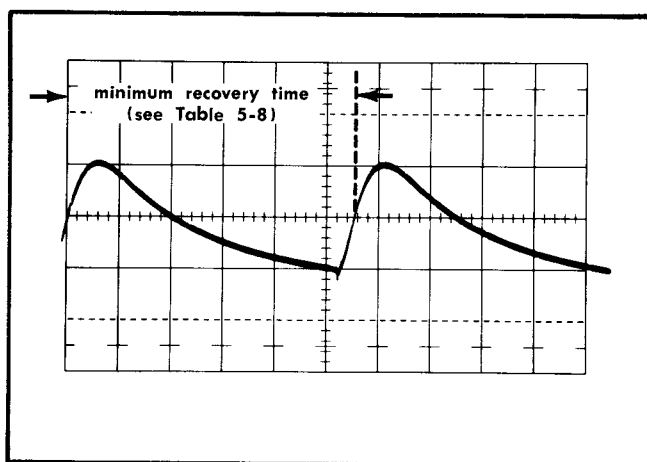

Fig. 5-66. Typical test oscilloscope display for checking minimum recovery time of Type 1S1 trigger circuit. (Recovery time on 50 nS time position range is illustrated).

TABLE 5-8  
Trigger Recovery Time

Type 1S1 TIME/CM	TIME POSITION RANGE	Test Oscilloscope Time/Cm	Recovery time limits (with RECOVERY TIME control ccw but not SYNC)
1 nSEC	50 nS	2 μSec	5.0-6.5 cm (10-13 μsec)
10 nSEC	500 nS	2 μSec	5.0-6.5 cm (10-13 μsec)
.1 μSEC	5 μS	5 μSec	4.0-5.4 cm (20-27 μsec)
1 μSEC	50 μS	50 μSec	4.0-5.4 cm (200-270 μsec)
10 μSEC	500 μS	.5 mSec	3.6-4.6 cm (1.8-2.3 msec)

- After completion of this step, disconnect the probe tip and reset the Type 1S1 DISPLAY MODE to NORMAL.

# SECTION 6

## PARTS LIST AND DIAGRAMS

### PARTS ORDERING INFORMATION

Replacement parts are available from or through your local Tektronix Field Office.

Changes to Tektronix instruments are sometimes made to accommodate improved components as they become available, and to give you the benefit of the latest circuit improvements developed in our engineering department. It is therefore important, when ordering parts, to include the following information in your order: Part number including any suffix, instrument type, serial number, and modification number if applicable.

If a part you have ordered has been replaced with a new or improved part, your local Tektronix Field Office will contact you concerning any change in part number.

### ABBREVIATIONS AND SYMBOLS

a or amp	amperes	mm	millimeter
BHS	binding head steel	meg or M	megohms or mega (10 <sup>6</sup> )
C	carbon	met.	metal
cer	ceramic	μ	micro, or 10 <sup>-6</sup>
cm	centimeter	n	nano, or 10 <sup>-9</sup>
comp	composition	Ω	ohm
cps	cycles per second	OD	outside diameter
crt	cathode-ray tube	OHS	oval head steel
CSK	counter sunk	p	pico, or 10 <sup>-12</sup>
dia	diameter	PHS	pan head steel
div	division	piv	peak inverse voltage
EMC	electrolytic, metal cased	plstc	plastic
EMT	electrolytic, metal tubular	PMC	paper, metal cased
ext	external	poly	polystyrene
f	farad	Prec	precision
F & I	focus and intensity	PT	paper tubular
FHS	flat head steel	PTM	paper or plastic, tubular, molded
Fil HS	fillister head steel	RHS	round head steel
g or G	giga, or 10 <sup>9</sup>	rms	root mean square
Ge	germanium	sec	second
GMV	guaranteed minimum value	Si	silicon
h	henry	S/N	serial number
hex	hexagonal	t or T	tera, or 10 <sup>12</sup>
HHS	hex head steel	TD	toroid
HSS	hex socket steel	THS	truss head steel
HV	high voltage	tub.	tubular
ID	inside diameter	v or V	volt
incd	incandescent	Var	variable
int	internal	w	watt
k or K	kilohms or kilo (10 <sup>3</sup> )	w/	with
kc	kilocycle	w/o	without
m	milli, or 10 <sup>-3</sup>	WW	wire-wound
mc	megacycle		

### SPECIAL NOTES AND SYMBOLS

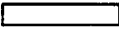
X000	Part first added at this serial number.
000X	Part removed after this serial number.
*000-000	Asterisk preceding Tektronix Part Number indicates manufactured by or for Tektronix, or reworked or checked components.
Use 000-000	Part number indicated is direct replacement.
	Internal screwdriver adjustment.
	Front-panel adjustment or connector.

EXPLODED VIEW

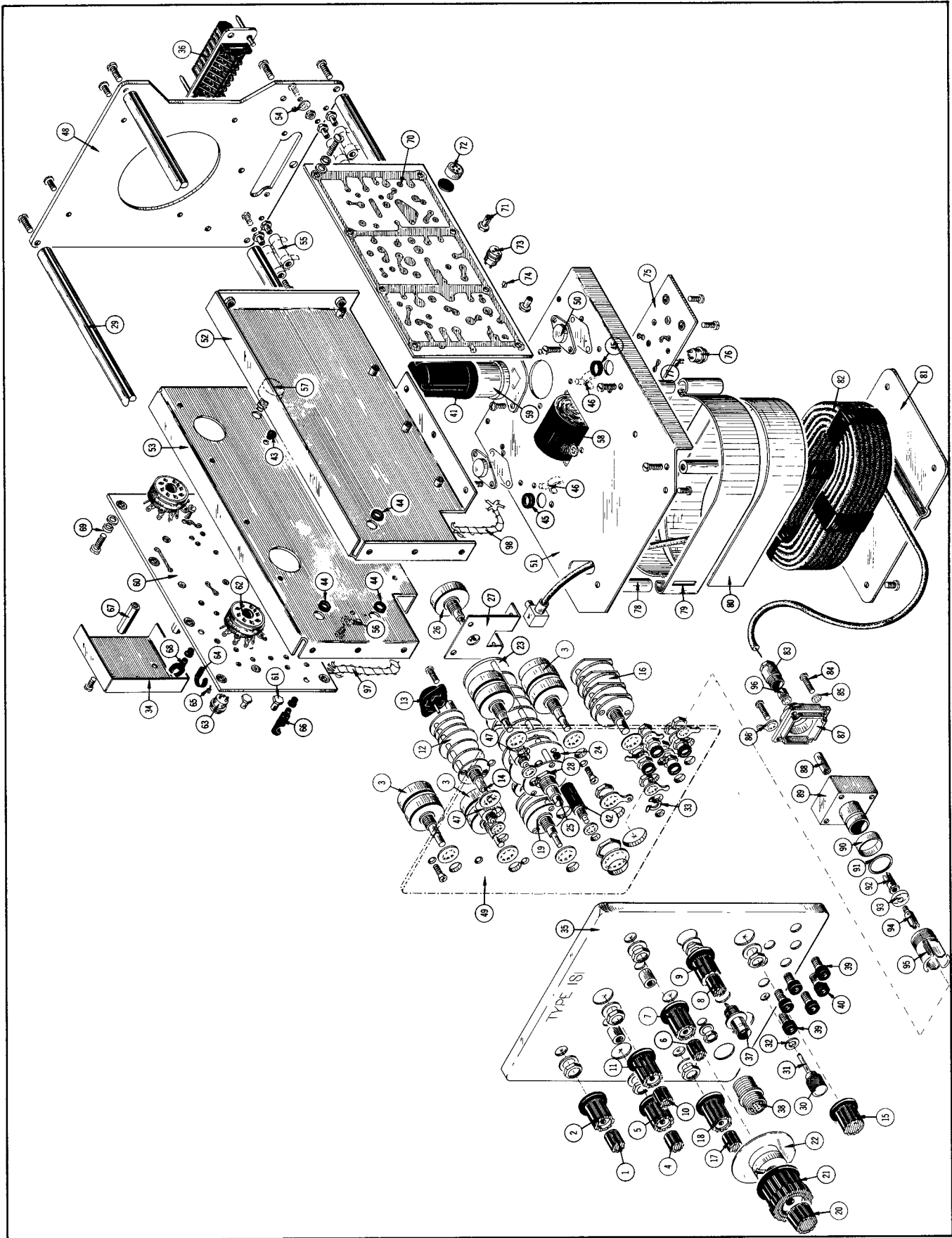

## EXPLODED VIEW

REF. NO.	PART NO.	SERIAL/MODEL NO.		QTY.	DESCRIPTION
		EFF.	DISC.		
1	366-0319-00			1	KNOB, red—FINE
	- - - - -			-	knob includes:
	213-0020-00			1	SCREW, set, 6-32 x 1/8 inch, HSS
2	366-0138-00			1	KNOB, charcoal—TIME POSITION
	- - - - -			-	knob includes:
	213-0004-00			1	SCREW, set, 6-32 x 3/16 inch, HSS
3	- - - - -			3	POT
	- - - - -			-	mounting hardware for each: (not included w/pot)
	210-0012-00			1	LOCKWASHER, pot, internal, 3/8 x 1/2 inch
	210-0840-00			1	WASHER, .390 ID x 9/16 inch OD
	210-0413-00			1	NUT, hex, 3/8-32 x 1/2 inch
4	366-0319-00			1	KNOB, red—SAMPLES/CM
	- - - - -			-	knob includes:
	213-0020-00			1	SCREW, set, 6-32 x 1/8 inch, HSS
5	366-0138-00			1	KNOB, charcoal—SMOOTHING
	- - - - -			-	knob includes:
	213-0004-00			1	SCREW, set, 6-32 x 3/16 inch, HSS
6	366-0319-00			1	KNOB, red—DC OFFSET ±1 V
	- - - - -			-	knob includes:
	213-0020-00			1	SCREW, set, 6-32 x 1/8 inch, HSS
7	366-0138-00			1	KNOB, charcoal—VERT POSITION
	- - - - -			-	knob includes:
	213-0004-00			1	SCREW, set, 6-32 x 3/16 inch, HSS
8	366-0189-00			1	KNOB, red—RECOVERY TIME
	- - - - -			-	knob includes:
	213-0020-00			1	SCREW, set, 6-32 x 1/8 inch, HSS
9	366-0175-00			1	KNOB, charcoal—TRIGGER SENSITIVITY
	- - - - -			-	knob includes:
	213-0004-00			1	SCREW, set, 6-32 x 3/16 inch, HSS
10	366-0189-00			1	KNOB, red—CAL VARIABLE
	- - - - -			-	knob includes:
	213-0020-00			1	SCREW, set, 6-32 x 1/8 inch, HSS
11	366-0175-00			1	KNOB, charcoal—mVOLTS/CM
	- - - - -			-	knob includes:
	213-0004-00			1	SCREW, set, 6-32 x 3/16 inch, HSS
12	262-0721-00			1	SWITCH, wired—mVOLTS/CM
	- - - - -			-	switch includes:
	260-0686-00			1	SWITCH, unwired—mVOLTS/CM
13	- - - - -			1	POT
	- - - - -			-	mounting hardware: (not included w/pot alone)
	166-0026-00			2	TUBE, spacer
	211-0016-00			2	SCREW, 4-40 x 5/8 inch, RHS
14	384-0358-00			1	ROD, extension
	- - - - -			-	mounting hardware: (not included w/switch)
	210-0012-00			1	LOCKWASHER, pot, internal, 3/8 x 1/2 inch
	210-0840-00			1	WASHER, .390 ID x 9/16 inch OD
	210-0413-00			1	NUT, hex, 3/8-32 x 1/2 inch

EXPLODED VIEW (Cont'd)

REF. NO.	PART NO.	SERIAL/MODEL NO.		QTY.	DESCRIPTION
		EFF.	DISC.		
15	366-0173-00			1	KNOB, charcoal—TRIGGER SOURCE
	- - - - -			-	knob includes:
	213-0004-00			1	SCREW, set, 6-32 x 3/16 inch, HSS
16	262-0719-00			1	SWITCH, wired—TRIGGER SOURCE
	- - - - -			-	switch includes:
	260-0685-00			1	SWITCH, unwired—TRIGGER SOURCE
	- - - - -			-	mounting hardware: (not included w/switch)
	210-0012-00			1	LOCKWASHER, pot, internal, 3/8 x 1/2 inch
	210-0840-00			1	WASHER, .390 ID x 9/16 inch OD
	210-0413-00			1	NUT, hex, 3/8-32 x 1/2 inch
17	366-0189-00			1	KNOB, red—MANUAL SCAN-EXT HORIZ ATTEN
	- - - - -			-	knob includes:
	213-0020-00			1	SCREW, set, 6-32 x 1/8 inch, HSS
18	366-0175-00			1	KNOB, charcoal—DISPLAY MODE
	- - - - -			-	knob includes:
	213-0004-00			1	SCREW, set, 6-32 x 3/16 inch, HSS
19	262-0718-00			1	SWITCH, wired—DISPLAY MODE
	- - - - -			-	switch includes:
	260-0687-00			1	SWITCH, unwired—DISPLAY MODE
	210-0046-00			1	LOCKWASHER, .400 OD x .261 inch ID
	210-0583-00			1	NUT, hex, 1/4-32 x 5/16 inch
	- - - - -			-	mounting hardware: (not included w/switch)
	210-0012-00			1	LOCKWASHER, pot, internal, 3/8 x 1/2 inch
	210-0840-00			1	WASHER, .390 ID x 9/16 inch OD
	210-0413-00			1	NUT, hex, 3/8-32 x 1/2 inch
20	366-0038-00			1	KNOB, red—CAL VARIABLE
	- - - - -			-	knob includes:
	213-0004-00			1	SCREW, set, 6-32 x 3/16 inch, HSS
21	366-0318-00			1	KNOB, charcoal—TIME/CM
	- - - - -			-	each knob includes:
	213-0022-00			1	SCREW, set, 4-40 x 3/16 inch, HSS
22	331-0155-00			1	DIAL—TIME POSITION RANGE
	- - - - -			-	dial includes:
	213-0022-00			2	SCREW, set, 4-40 x 3/16 inch, HSS
23	262-0721-00			1	SWITCH, wired—TIME/CM (See Ref. #28)
	- - - - -			-	switch includes:
	260-0684-00			1	SWITCH, unwired—TIME/CM
24	348-0031-00			3	GROMMET, polypropylene, snap-in, 1/4 inch diameter
25	384-0137-00			1	ROD, extension
26	- - - - -			1	POT
	- - - - -			-	mounting hardware: (not included w/pot alone)
	210-0012-00			1	LOCKWASHER, pot, internal, 3/8 x 9/16 inch
	210-0413-00			1	NUT, hex, 3/8-32 x 1/2 inch
27	407-0135-00			1	BRACKET
	- - - - -			-	mounting hardware: (not included w/bracket alone)
	210-0006-00			2	LOCKWASHER, internal, #6
	210-0449-00			2	NUT, hex, 5-40 x 1/4 inch



## EXPLODED VIEW (Cont'd)

REF. NO.	PART NO.	SERIAL/MODEL NO.		QTY.	DESCRIPTION
		EFF.	DISC.		
28	- - - - - 210-0586-00 210-0579-00 210-0049-00			- 2 1 1	mounting hardware: (not included w/switch) NUT, keps, 4-40 x 1/4 inch NUT, hex, 5/8-24 x 3/4 inch LOCKWASHER, internal, 5/8 inch ID
29	384-0631-00 - - - - - 212-0046-00			4 - 1	ROD, frame mounting hardware for each: (not included w/rod) SCREW, 8-32 x 3/8 inch, THS phillips
30	366-0125-00 - - - - - 213-0005-00			1 - 1	KNOB, plug-in securing knob includes: SCREW, set, 8-32 x 1/8 inch, HSS
31	384-0510-00			1	ROD, securing
32	210-0894-00			1	WASHER, polyethylene, .567 OD x .033 inch ID
33	354-0025-00			1	RING, retaining
34	337-0743-00 - - - - - 211-0504-00			1 - 2	SHIELD mounting hardware: (not included w/shield) SCREW, 6-32 x 1/4 inch, BHS
35	333-0873-00			1	PANEL, front
36	131-0017-00 - - - - - 211-0008-00 210-0586-00			1 1 - 2 2	CONNECTOR, 16 contact mounting hardware: (not included w/connector) SCREW, 4-40 x 1/4 inch, BHS NUT, keps, 4-40 x 1/4 inch
37	131-0106-00 - - - - - 210-0255-00			1 - 1	CONNECTOR, coax, w/nut mounting hardware: (not included w/connector) LUG, solder, 3/8 inch
38	131-0206-00 - - - - - 210-0260-00 210-0559-00			1 - 1 1	CONNECTOR, probe power mounting hardware: (not included w/connector) LUG, solder NUT, hex, 7/16-28 x 9/16 inch
39	136-0140-00 - - - - - 210-0223-00 210-0465-00			2 - 1 1	SOCKET, banana jack mounting hardware for each: (not included w/socket) LUG, solder NUT, hex, 1/4-32 x 3/8 inch
40	136-0140-00 - - - - - 210-0895-00 210-0223-00 210-0465-00			4 - 1 1 2	SOCKET, banana jack mounting hardware for each: (not included w/socket) WASHER, insulating LUG, solder NUT, hex, 1/4-32 x 3/8 inch
41	200-0293-00			1	COVER, capacitor, polyethylene, 2 7/16 x 1.365 inch ID
42	260-0689-00 - - - - - 210-0046-00 210-0940-00 210-0583-00			1 - 1 1 2	SWITCH, unwired—START mounting hardware: (not included w/switch) LOCKWASHER, .400 OD x .261 inch ID WASHER, 1/4 ID x 3/8 inch OD NUT, hex, 1/4-32 x 5/16 inch

EXPLODED VIEW (Cont'd)

REF. NO.	PART NO.	SERIAL/MODEL NO.		QTY.	DESCRIPTION
		EFF.	DISC.		
43	348-0031-00			1	GROMMET, polyethylene, snap-in, 1/4 inch diameter
44	348-0056-00			3	GROMMET, delrin, .406 OD x .353 inch ID
45	348-0063-00			2	GROMMET, delrin, .500 OD x .485 inch ID
46	352-0086-00			2	HOLDER
47	- - - - -			2	POT
	- - - - -			-	mounting hardware for each: (not included w/pot)
	210-0046-00			1	LOCKWASHER, .400 OD x .261 inch ID
	358-0075-00			1	BUSHING, 1/4-32 x .343 inch
48	386-0150-00			1	PLATE, subpanel, rear
49	386-0152-00			1	PLATE, subpanel, front
50	- - - - -			2	TRANSISTOR
	- - - - -			-	mounting hardware for each: (not included w/transistor)
	211-0510-00			2	SCREW, 6-32 x 3/8 inch, BHS
	386-0143-00			1	PLATE, insulating
	210-0983-00			2	WASHER, shouldered
	210-0802-00			2	WASHER, 6S x 5/16 inch
	210-0006-00			1	LOCKWASHER, internal, #6
	210-0202-00			1	LUG, solder
	210-0407-00			2	NUT, hex, 6-32 x 1/4 inch
51	441-0616-00			1	CHASSIS, power
	- - - - -			-	mounting hardware: (not included w/chassis)
	211-0504-00			3	SCREW, 6-32 x 1/4 inch, BHS
	210-0457-00			6	NUT, keps, 6-32 x 5/16 inch
52	441-0617-00			1	CHASSIS, horizontal
	- - - - -			-	mounting hardware: (not included w/chassis)
	211-0504-00			2	SCREW, 6-32 x 1/4 inch, BHS
	211-0538-00			3	SCREW, 6-32 x 5/16 inch, 100° CSK, FHS phillips
	210-0457-00			2	NUT, keps, 6-32 x 5/16 inch
53	441-0618-00			1	CHASSIS, vertical
	- - - - -			-	mounting hardware: (not included w/chassis)
	211-0504-00			2	SCREW, 6-32 x 1/4 inch, BHS
	211-0538-00			3	SCREW, 6-32 x 5/16 inch, 100° CSK, FHS phillips
	210-0457-00			2	NUT, keps, 6-32 x 5/16 inch
54	210-0202-00			1	LUG, solder
	- - - - -			-	mounting hardware: (not included w/lug)
	211-0504-00			1	SCREW, 6-32 x 1/4 inch, BHS
	210-0407-00			1	NUT, hex, 6-32 x 1/4 inch
55	- - - - -			5	RESISTOR, 1 watt
	- - - - -			-	mounting hardware for each: (not included w/resistor)
	211-0507-00			1	SCREW, 6-32 x 5/16 inch, BHS
	210-0478-00			1	NUT, hex, 5/16 x 2 1/32 inch long
	211-0544-00			1	SCREW, 6-32 x 3/4 inch, THS phillips

## EXPLODED VIEW (Cont'd)

REF. NO.	PART NO.	SERIAL/MODEL NO.		QTY.	DESCRIPTION
		EFF.	DISC.		
56	210-0201-00 ----- 213-0044-00			3 - 1	LUG, solder mounting hardware for each: (not included w/lug) SCREW, thread cutting, 5-32 x 3/16 inch, PHS phillips
57	----- ----- 210-0940-00 210-0583-00			1 - 1 1	POT mounting hardware: (not included w/pot) WASHER, 1/4 ID x 3/8 inch OD NUT, hex, 1/4-32 x 5/16 inch
58	----- ----- 211-0021-00 210-0004-00 210-0406-00			1 - 2 2 2	TRANSFORMER mounting hardware: (not included w/transformer) SCREW, 4-40 x 1 1/4 inches, RHS LOCKWASHER, internal, #4 NUT, hex, 4-40 x 3/16 inch
59	----- ----- 386-0254-00 211-0597-00			1 - 1 2	CAPACITOR mounting hardware: (not included w/capacitor) PLATE, fiber, large SCREW, 6-32 x 1/4 inch, RHS phillips
60	670-0078-00 ----- 388-0640-00			1 - 1	ASSEMBLY, board, (VERTICAL) (See Ref. #69) assembly includes: BOARD, etched circuit
61	131-0391-00			2	CONNECTOR, male
62	136-0061-00			2	SOCKET, 9 pin
63	136-0183-00			8	SOCKET, transistor, 3 pin
64	343-0088-00			1	CLAMP, cable
65	344-0108-00			14	CLIP, diode
66	352-0017-00 ----- 361-0007-00			1 - 1	HOLDER, nylon mounting hardware: (not included w/holder alone) SPACER, nylon
67	384-0519-00 ----- 211-0504-00			2 - 1	ROD, spacing mounting hardware for each: (not included w/rod alone) SCREW, 6-32 x 1/4 inch, BHS
68	426-0121-00 ----- 361-0007-00			1 - 1	MOUNT, toroid mounting hardware: (not included w/mount alone) SPACER, nylon
69	----- 211-0504-00 210-0055-00 210-0802-00			1 6 6 6	mounting hardware: (not included w/assembly) SCREW, 6-32 x 1/4 inch, BHS LOCKWASHER, #6 split WASHER, 6S x 5/16 inch

EXPLODED VIEW (Cont'd)

REF. NO.	PART NO.	SERIAL/MODEL NO.		QTY.	DESCRIPTION
		EFF.	DISC.		
70	670-0079-00			1	ASSEMBLY, board (HORIZONTAL)
	- - - - -			-	assembly includes:
	388-0639-00			1	BOARD, etched circuit
71	131-0391-00			2	CONNECTOR, male
72	136-0125-00			1	SOCKET, 5 pin
	387-0603-00			1	PLATE, insulating
73	136-0183-00			18	SOCKET, transistor, 3 pin
74	344-0108-00			2	CLIP, diode
	- - - - -			-	mounting hardware: (not included w/assembly)
	211-0504-00			8	SCREW, 6-32 x 1/4 inch, BHS
	210-0055-00			8	LOCKWASHER, #6 split
	210-0802-00			8	WASHER, 6S x 5/16 inch
75	670-0080-00			1	ASSEMBLY, board (REGULATOR)
	- - - - -			-	assembly includes:
	388-0638-00			1	BOARD, etched circuit
76	136-0183-00			3	SOCKET, transistor, 3 pin
77	344-0108-00			2	CLIP, diode
	- - - - -			-	mounting hardware: (not included w/assembly)
	211-0504-00			4	SCREW, 6-32 x 1/4 inch, BHS
	210-0055-00			4	LOCKWASHER, #6 split
	210-0802-00			4	WASHER, 6S x 5/16 inch
78	385-0184-00			4	ROD, spacer
	- - - - -			-	mounting hardware for each: (not included w/rod)
	211-0507-00			1	SCREW, 6-32 x 5/16 inch, BHS
79	380-0073-00			1	HOUSING, delay line
80	337-0751-00			1	SHIELD, delay line
81	386-0151-00			1	PLATE, delay line
	- - - - -			-	mounting hardware: (not included w/plate)
	211-0507-00			4	SCREW, 6-32 x 5/16 inch, BHS

## EXPLODED VIEW (Cont'd)

REF. NO.	PART NO.	SERIAL/MODEL NO.		Q T Y.	DESCRIPTION
		EFF.	DISC.		
82	119-0054-00			1	ASSEMBLY, DELAY LINE
	- - - - -			-	assembly includes:
83	131-0007-00			1	CONNECTOR, cable end
84	211-0507-00			2	SCREW, 6-32 x $\frac{5}{16}$ inch, BHS
85	210-0006-00			2	LOCKWASHER, internal, #6
86	210-0202-00			1	LUG, solder
87	200-0365-00			1	COVER
88	358-0088-00			1	BUSHING
89	380-0035-00			1	HOUSING
90	132-0001-00			1	NUT, coupling
91	132-0007-00			1	SNAP, ring
92	131-0209-00			1	CONNECTOR, inner conductor
93	132-0028-00			1	INSULATOR
94	132-0029-00			1	CONDUCTOR, inner
95	132-0002-00			1	CONDUCTOR, sleeve, outer
96	- - - - -			-	mounting hardware: (not included w/assembly)
	210-0006-00			1	LOCKWASHER, internal #6
	210-0561-00			2	NUT, 6-32 x $\frac{3}{16}$ inch
97	179-0981-00			1	CABLE HARNESS, vertical
98	179-0982-00			1	CABLE HARNESS, horizontal

ACCESSORIES

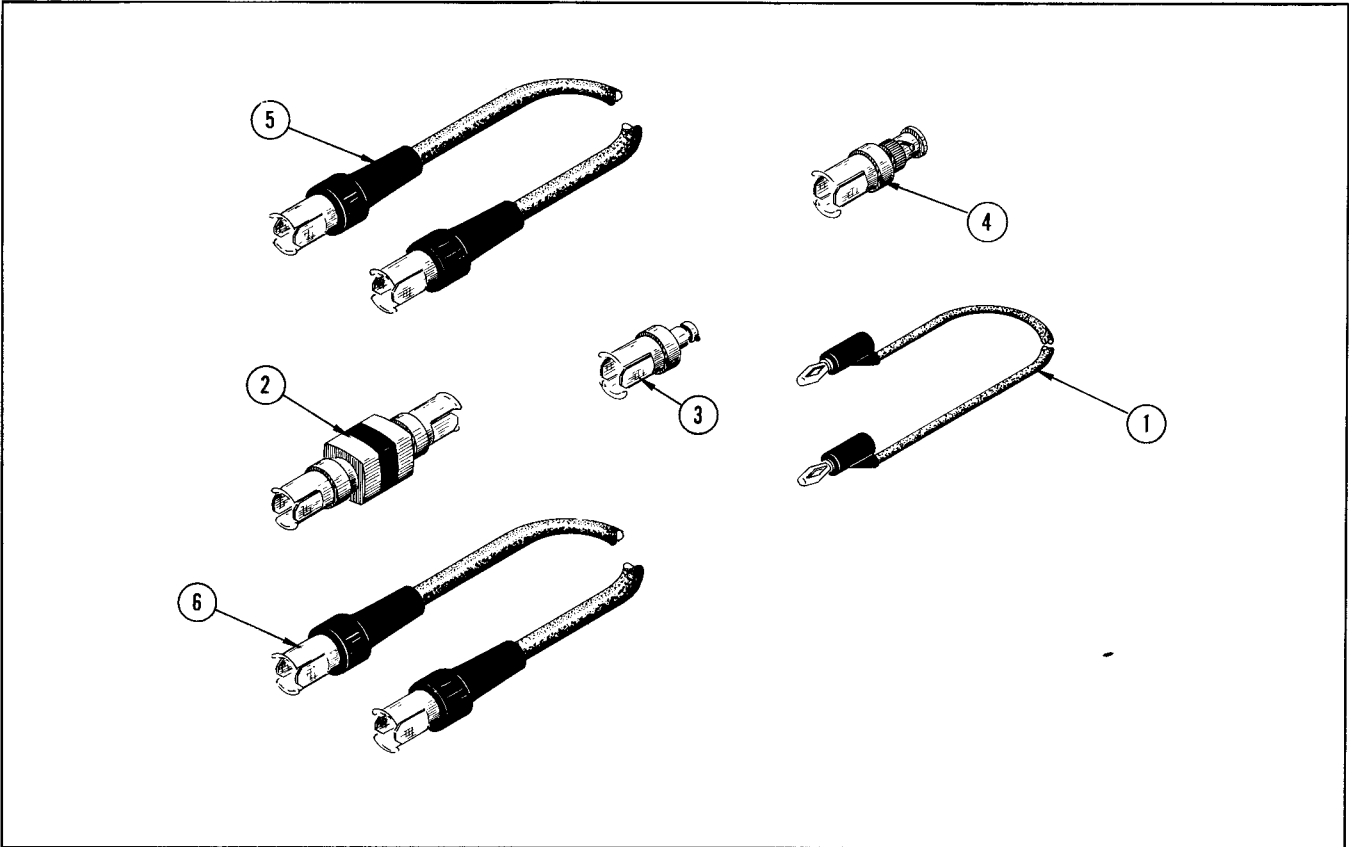

REF. NO.	PART NO.	SERIAL/MODEL NO.		QTY.	DESCRIPTION
		EFF.	DISC.		
1	012-0039-00			1	CORD, patch-banana, 18 inches
2	017-0044-00			2	ATTENUATOR, 50 $\Omega$ , 10 X
3	017-0063-00			1	ADAPTER, BNC to GR (female)
4	017-0064-00			1	ADAPTER, BNC to GR (male)
5	017-0501-00			1	CABLE, 50 $\Omega$ , 10 nsec
6	017-0502-00			1	CABLE, 50 $\Omega$ , 5 nsec

STANDARD ACCESSORIES

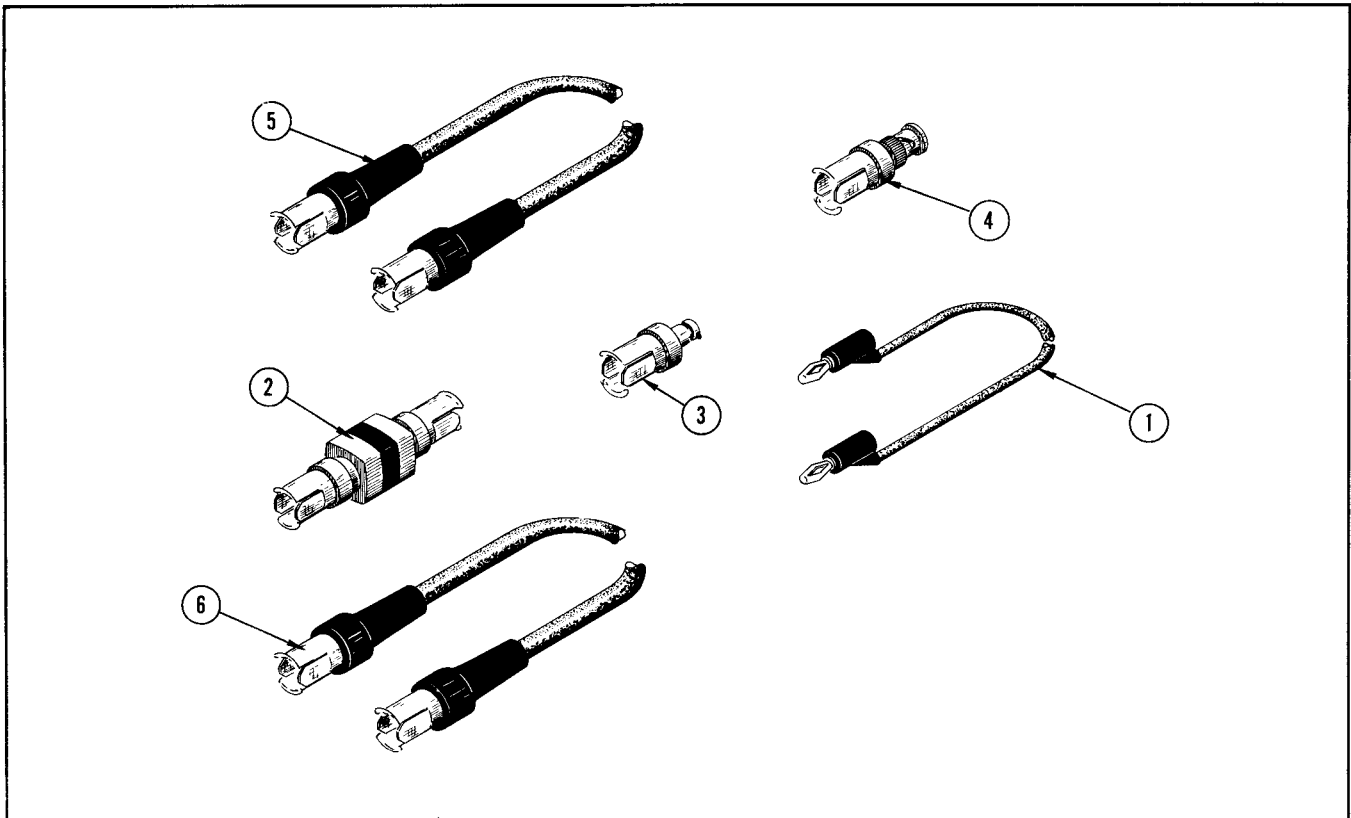

REF. NO.	PART NO.	SERIAL/MODEL NO.		QTY.	DESCRIPTION
		EFF.	DISC.		
1	012-0039-00			1	CORD, patch-banana, 18 inches
2	017-0044-00	100	149	2	ATTENUATOR, 50 Ω, 10 X
	017-0078-00	150		2	ATTENUATOR, 50 Ω, 10 X
3	017-0063-00			1	ADAPTER, BNC to GR (female)
4	017-0064-00			1	ADAPTER, BNC to GR (male)
5	017-0501-00			1	CABLE, 50 Ω, 10 nsec
6	017-0502-00			1	CABLE, 50 Ω, 5 nsec
	070-0475-00			2	MANUAL, instruction

## ELECTRICAL PARTS

Values are fixed unless marked variable.

Ckt. No.	Tektronix Part No.	Description	S/N Range			
<b>Capacitors</b>						
Tolerance $\pm 20\%$ unless otherwise indicated.						
C4 } C5 }	*283-0123-00	Assembly	Cer		100-149	
C4 } C5 }	*283-0124-00	Assembly	Cer		150-up	
C33	281-0578-00	18 pf	Cer	500 v	5%	
C36	281-0538-00	1 pf	Cer	500 v		
C37	281-0538-00	1 pf	Cer	500 v		
C39	283-0059-00	1 $\mu$ f	Cer	25 v		
C42	283-0079-00	0.01 $\mu$ f	Cer	250 v		
C49	283-0059-00	1 $\mu$ f	Cer	25 v		
C54	283-0059-00	1 $\mu$ f	Cer	25 v		
C56	283-0065-00	0.001 $\mu$ f	Cer	100 v	5%	
C66	283-0059-00	1 $\mu$ f	Cer	25 v		
C68	283-0092-00	0.03 $\mu$ f	Cer	200 v		
C74	283-0026-00	0.2 $\mu$ f	Cer	25 v		
C76	283-0594-00	0.001 $\mu$ f	Mica	100 v	1%	
C80	283-0067-00	0.001 $\mu$ f	Cer	200 v	10%	
C81	281-0523-00	100 pf	Cer	350 v		
C82	283-0067-00	0.001 $\mu$ f	Cer	200 v	10%	
C83	283-0059-00	1 $\mu$ f	Cer	25 v		
C84	281-0573-00	11 pf	Cer		10%	
C85	283-0067-00	0.001 $\mu$ f	Cer	200 v	10%	
C86	283-0079-00	0.01 $\mu$ f	Cer	250 v		
C87	281-0503-00	8 pf	Cer	500 v	$\pm 0.5$ pf	
C88	283-0069-00	15 pf	Cer	50 v		
C89	283-0069-00	15 pf	Cer	50 v		
C93	283-0026-00	0.2 $\mu$ f	Cer	25 v		
C101	283-0026-00	0.2 $\mu$ f	Cer	25 v		
C110	283-0051-00	0.0033 $\mu$ f	Cer	100 v	5%	
C115	283-0067-00	0.001 $\mu$ f	Cer	200 v	10%	
C122	281-0504-00	10 pf	Cer	500 v	10%	
C133	283-0026-00	0.2 $\mu$ f	Cer	25 v		
C135	281-0022-00	8-50 pf	Cer	Var		
C136	283-0618-00	130 pf	Mica		300 v	2%
C145	283-0067-00	0.001 $\mu$ f	Cer		200 v	10%
C157	283-0079-00	0.01 $\mu$ f	Cer		250 v	
C192	283-0079-00	0.01 $\mu$ f	Cer		250 v	
C205	283-0077-00	330 pf	Cer	500 v	5%	
C210	285-0598-00	0.01 $\mu$ f	PTM	100 v	5%	
C220	283-0060-00	100 pf	Cer	200 v	5%	
C228	283-0000-00	0.001 $\mu$ f	Cer	500 v		
C232	283-0004-00	0.02 $\mu$ f	Cer	150 v		



Parts List—Type 1S1

Capacitors (Cont'd)

Ckt. No.	Tektronix Part No.		Description			S/N Range
C240	283-0060-00	100 pf	Cer	200 v		5%
C246	285-0598-00	0.01 $\mu$ f	PTM	100 v		5%
C249	283-0060-00	100 pf	Cer	200 v		5%
C250	283-0004-00	0.02 $\mu$ f	Cer	150 v		
C257	283-0004-00	0.02 $\mu$ f	Cer	150 v		
C258	283-0054-00	150 pf	Cer	200 v		5%
C262	285-0643-00	0.0047 $\mu$ f	PTM	100 v		5%
C266	283-0004-00	0.02 $\mu$ f	Cer	150 v		
C269	283-0004-00	0.02 $\mu$ f	Cer	150 v		
C272	283-0060-00	100 pf	Cer	200 v		5%
C276	283-0060-00	100 pf	Cer	200 v		5%
C283	283-0004-00	0.02 $\mu$ f	Cer	150 v		
C285	283-0067-00	0.001 $\mu$ f	Cer	200 v		10%
C298	283-0004-00	0.02 $\mu$ f	Cer	150 v		
C299	283-0004-00	0.02 $\mu$ f	Cer	150 v		
C302	283-0599-00	98 pf	Mica	500 v		5%
C306	283-0051-00	0.0033 $\mu$ f	Cer	100 v		5%
C313	283-0081-00	0.1 $\mu$ f	Cer	25 v		
C315	283-0060-00	100 pf	Cer	250 v		5%
C325	281-0063-00	9-35 pf	Cer		Var	
C326A	*295-0087-00	0.5 $\mu$ f	Timing Capacitor			
C326B		0.05 $\mu$ f				
C326C		0.00495 $\mu$ f				
C326D		450 pf				
C330	283-0081-00	0.1 $\mu$ f	Cer	25 v		
C335	283-0004-00	0.02 $\mu$ f	Cer	150 v		
C342	283-0115-00	47 pf	Cer	200 v		5%
C357	283-0081-00	0.1 $\mu$ f	Cer	25 v		
C362	283-0000-00	0.001 $\mu$ f	Cer	500 v		
C377	283-0076-00	27 pf	Cer	500 v		10%
C380	283-0000-00	0.001 $\mu$ f	Cer	500 v		
C391	283-0004-00	0.02 $\mu$ f	Cer	150 v		
C397	283-0081-00	0.1 $\mu$ f	Cer	25 v		
C399	283-0081-00	0.1 $\mu$ f	Cer	25 v		
C412	283-0079-00	0.01 $\mu$ f	Cer	250 v		
C413	283-0079-00	0.01 $\mu$ f	Cer	250 v		
C415	283-0081-00	0.1 $\mu$ f	Cer	25 v		
C418	283-0069-00	15 pf	Cer	50 v		
C420	283-0004-00	0.02 $\mu$ f	Cer	150 v		
C424	283-0072-00	0.01 $\mu$ f	Cer			
C435	283-0004-00	0.02 $\mu$ f	Cer	150 v		
C446	283-0599-00	98 pf	Mica	500 v		5%
C448	283-0599-00	98 pf	Mica	500 v		5%
C454	283-0081-00	0.1 $\mu$ f	Cer	25 v		

## Capacitors (Cont'd)

Ckt. No.	Tektronix Part No.		Description		S/N Range
C461	283-0119-00	0.0022 $\mu$ f	Cer	200 v	5%
C462	283-0070-00	30 pf	Cer	50 v	10%
C464	283-0059-00	1 $\mu$ f	Cer	25 v	
C475	283-0000-00	0.001 $\mu$ f	Cer	500 v	
C479	283-0116-00	820 pf	Cer	500 v	5%
C480A	285-0683-00	0.022 $\mu$ f	PTM	100 v	5%
C480B	290-0269-00	0.22 $\mu$ f	EMT	35 v	5%
C480C	283-0114-00	0.0015 $\mu$ f	Cer	200 v	
C487	283-0060-00	100 pf	Cer	200 v	5%
C497	283-0004-00	0.02 $\mu$ f	Cer	150 v	
C614	283-0067-00	0.001 $\mu$ f	Cer	200 v	10%
C627	290-0215-00	100 $\mu$ f	EMT	25 v	
C632	290-0122-00	1000 $\mu$ f	EMC	50 v	
C634	283-0092-00	0.03 $\mu$ f	Cer	200 v	
C657	290-0215-00	100 $\mu$ f	EMT	25 v	

## Diodes

D11A,B,C,D	Use *153-0014-00	GaAs, 1 matched set		
D66	*152-0185-00	Silicon	Replaceable by IN3605	
D80	152-0071-00	Germanium	ED 2007	
D82	152-0071-00	Germanium	ED 2007	
D87	*152-0115-00	GaAs	Tek made	
D90	152-0071-00	Germanium	ED 2007	
D92	*152-0185-00	Silicon	Replaceable by IN3605	
D101	152-0034-00	Zener	1N753 0.4 w, 6.2 v, 5%	
D103	152-0071-00	Germanium	ED 2007	
D107	152-0071-00	Germanium	ED 2007	
D109	*152-0185-00	Silicon	Replaceable by IN3605	
D110	*152-0083-00	GaAs, 1 pair,	Tek made	
D112				
D118	*152-0107-00	Silicon	Replaceable by 1N647	
D175	*152-0185-00	Silicon	Replaceable by IN3605	
D183	*152-0185-00	Silicon	Replaceable by IN3605	
D185	*152-0185-00	Silicon	Replaceable by IN3605	
D186	*152-0185-00	Silicon	Replaceable by IN3605	
D187	*152-0185-00	Silicon	Replaceable by IN3605	
D188	*152-0185-00	Silicon	Replaceable by IN3605	
D205	*152-0185-00	Silicon	Replaceable by 1N3605	
D210	*152-0185-00	Silicon	Replaceable by 1N3605	
D215	*152-0185-00	Silicon	Replaceable by 1N3605	
D216	152-0141-00	Silicon	IN3605	
D237	*152-0185-00	Silicon	Replaceable by 1N3605	

**Parts List—Type 1S1**

**Diodes (Cont'd)**

Ckt. No.	Tektronix Part No.		Description	S/N Range
D246	*152-0045-00	Silicon	Selected from 1N622A	
D247	*152-0075-00	Germanium	Tek Spec	
D260	*152-0185-00	Silicon	Replaceable by 1N3605	
D262	*152-0045-00	Silicon	Selected from 1N622A	
D272	*152-0185-00	Silicon	Replaceable by 1N3605	
D285	152-0139-00	Zener	1N751	0.4 w, 5.1 v, 10%
D292	*152-0185-00	Silicon	Replaceable by 1N3605	
D297	*152-0185-00	Silicon	Replaceable by 1N3605	
D304	152-0214-00	Tunnel	TD252	4.7 MA
D315	*152-0205-00	GaAs	Tek made	
D340	*152-0125-00	Tunnel	Selected TD3A	4.7 MA
D345	152-0214-00	Tunnel	TD252	4.7 MA
D362	*152-0211-00	GaAs	Tek made	
D430	152-0177-00	Tunnel	TD253B	10 MA
D432	152-0070-00	Back	BD4	0.1 MA
D449	152-0154-00	Tunnel	TD253	10 MA
D456	152-0008-00	Germanium		
D462	152-0008-00	Germanium		
D464	152-0008-00	Germanium		
D470	152-0008-00	Germanium		
D472	*152-0185-00	Silicon	Replaceable by 1N3605	
D482	*152-0185-00	Silicon	Replaceable by 1N3605	
D490	152-0008-00	Germanium		
D492	152-0008-00	Germanium		
D616	*152-0185-00	Silicon	Replaceable by 1N3605	
D630	152-0066-00	Silicon	1N3194	
D632	152-0066-00	Silicon	1N3194	
D636	*152-0185-00	Silicon	Replaceable by 1N3605	
D638	152-0008-00	Germanium		
D645	152-0034-00	Zener	1N753	0.4 w, 6.2 v, 10%
D662	152-0034-00	Zener	1N753	0.4 w, 6.2 v, 10%

**Connectors**

J1†				
J5†				
P5††	131-0391-00	Coax, male		
P11	131-0017-00	Chassis mtd., 16 contact, male		
J88	131-0375-00	Right Angle, coax, female		
P88††	131-0391-00	Coax, male		
J140	*136-0140-00	Socket, Banana Jack Assy.		
J145	*136-0140-00	Socket, Banana Jack Assy.		
J285	*136-0140-00	Socket, Banana Jack Assy.		
J295	*136-0140-00	Socket, Banana Jack Assy.		
J320	131-0375-00	Right Angle, coax, female		

†Part of Delay Line Assy. (\*119-0054-00).

††Mounted on Etched Wiring Board.

## Connectors (Cont'd)

Ckt. No.	Tektronix Part No.	Description	S/N Range
P320†	131-0391-00	Coax, male	
J400	131-0106-00	Chassis mtd., 1 contact, female	
J410	131-0375-00	Right Angle, coax, female	
P410†	131-0391-00	Coax, male	
P640	131-0206-00	Probe Power	

## Inductors

L2	276-0535-00	Core, Toroid	
L5	*119-0054-00	Delay Line Assembly	
L10	*308-0357-00	4.7 $\mu$ h (670 $\Omega$ WW resistor)	
L11	*308-0358-00	1.4 $\mu$ h (1400 $\Omega$ WW resistor)	
L52	*120-0306-00	Toroid, 40 turns single	
L130	*120-0402-00	Toroid, 3 turns	
L250	*120-0342-00	Toroid, 10 turns	
L302	276-0543-00	Core, Ferrite	
L326	276-0549-00	Core, Ferrite	
L350	276-0535-00	Core, Toroid	
L352	276-0549-00	Core, Ferrite	
L354	276-0549-00	Core, Ferrite	
L428	*108-0170-01	0.5 $\mu$ h	
L449	276-0543-00	Core, Ferrite	

## Transistors

Q54	*151-0134-00	Replaceable by 2N2905
Q64	*151-0108-00	Replaceable by 2N2501
Q74	*151-0151-00	Replaceable by 2N930
Q80	*151-0083-00	Selected from 2N964
Q94	151-0063-00	2N2207
Q124	*151-0151-00	Replaceable by 2N930
Q133	*151-0151-00	Replaceable by 2N930
Q153	*151-0151-00	Replaceable by 2N930
Q225	*151-0133-00	Selected from 2N3251
Q235	*151-0108-00	Replaceable by 2N2501
Q244	151-0040-00	2N1302
Q254	*151-0151-00	Replaceable by 2N930
Q271	*151-0136-00	Replaceable by 2N3053
Q283	*151-0136-00	Replaceable by 2N3053
Q294	*151-0151-00	Replaceable by 2N930
Q313	*151-0108-00	Replaceable by 2N2501
Q324	151-0130-00	2N1195
Q334	*151-0108-00	Replaceable by 2N2501
Q344	*151-0083-00	Selected from 2N964
Q354	*151-0151-00	Replaceable by 2N930

†Mounted on Etched Wiring Board.

**Parts List—Type 1S1**

**Transistors (Cont'd)**

Ckt. No.	Tektronix Part No.	Description	S/N Range
Q374	*151-0151-00	Replaceable by 2N930	
Q384	*151-0133-00	Selected from 2N3251	
Q424	*151-0142-00	Selected from 2N3546	
Q454	*151-0103-00	Replaceable by 2N2219	
Q464	*151-0134-00	Replaceable by 2N2905	
Q485	151-0162-00	2N3324	
Q495	*151-0151-00	Replaceable by 2N930	
Q614	*151-0151-00	Replaceable by 2N930	
Q624	*151-0134-00	Replaceable by 2N2905	
Q627	*151-0148-00	Selected (RCA 40250)	
Q634	*151-0151-00	Replaceable by 2N930	
Q653	*151-0136-00	Replaceable by 2N3053	
Q657	*151-0148-00	Selected (RCA 40250)	
Q667	*151-0136-00	Replaceable by 2N3053	

**Resistors**

Resistors are fixed, composition,  $\pm 10\%$  unless otherwise indicated.

R1	*308-0224-00	2.45 k	1/2 w	WW	1%
R4	317-0047-00	4.7 $\Omega$	1/8 w		5%
R5	317-0150-00	15 $\Omega$	1/8 w		5%
R7	321-0636-00	100 $\Omega$	1/8 w	Prec	1/2%
R8	321-0636-00	100 $\Omega$	1/8 w	Prec	1/2%
R13	315-0512-00	5.1 k	1/4 w		5%
R14	315-0223-00	22 k	1/4 w		5%
R16	323-0490-00	1.24 meg	1/2 w	Prec	1%
R17	323-0474-00	845 k	1/2 w	Prec	1%
R19	321-0305-00	14.7 k	1/8 w	Prec	1%
R21	315-0512-00	5.1 k	1/4 w		5%
R22	311-0497-00	50 k		Var	Bridge Volts
R24	323-0469-00	750 k	1/2 w	Prec	1%
R25	323-0498-00	1.5 meg	1/2 w	Prec	1%
R27	321-0305-00	14.7 k	1/8 w	Prec	1%
R30	311-0510-00	10 k		Var	Bridge Bal
R32	321-0324-00	23.2 k	1/8 w	Prec	1%
R33	321-0452-00	499 k	1/8 w	Prec	1%
R34	321-0381-00	90.9 k	1/8 w	Prec	1%
R36	317-0200-00	20 $\Omega$	1/8 w		5%
R38	308-0291-00	2 k	3 w	WW	5%
R39	321-0122-00	182 $\Omega$	1/8 w	Prec	1%
R42	321-0374-00	76.8 k	1/8 w	Prec	1%
R44	308-0310-00	12 k	5 w	WW	1%
R47	323-0404-00	158 k	1/2 w	Prec	1%

## Resistors (Cont'd)

Ckt. No.	Tektronix Part No.		Description		S/N Range
R49	315-0101-00	100 $\Omega$	$\frac{1}{4}$ w		5%
R51	308-0291-00	2 k	$\frac{3}{8}$ w	WW	5%
R52	321-0247-00	3.65 k	$\frac{1}{8}$ w	Prec	1%
R54	315-0101-00	100 $\Omega$	$\frac{1}{4}$ w		5%
R56†	311-0535-00	2.5 k		Var	SMOOTHING
R58A	321-0661-00	600 $\Omega$	$\frac{1}{8}$ w	Prec	1%
R58B	321-0126-00	200 $\Omega$	$\frac{1}{8}$ w	Prec	1%
R58C	321-0097-00	100 $\Omega$	$\frac{1}{8}$ w	Prec	1%
R58D	321-0657-00	60 $\Omega$	$\frac{1}{8}$ w	Prec	1%
R58E	321-0030-00	20 $\Omega$	$\frac{1}{8}$ w	Prec	1%
R58F	321-0001-00	10 $\Omega$	$\frac{1}{8}$ w	Prec	1%
R60A	321-0660-00	417 $\Omega$	$\frac{1}{8}$ w	Prec	1%
R60B	321-0659-00	139 $\Omega$	$\frac{1}{8}$ w	Prec	1%
R60C	321-0658-00	69.4 $\Omega$	$\frac{1}{8}$ w	Prec	1%
R60D	321-0656-00	21.3 $\Omega$	$\frac{1}{8}$ w	Prec	1%
R60E	321-0655-00	10.3 $\Omega$	$\frac{1}{8}$ w	Prec	1%
R60F	321-0654-00	10.1 $\Omega$	$\frac{1}{8}$ w	Prec	1%
R62	321-0193-00	1 k	$\frac{1}{8}$ w	Prec	1%
R64	323-0339-00	33.2 k	$\frac{1}{2}$ w	Prec	1%
R66	321-0250-00	3.92 k	$\frac{1}{8}$ w	Prec	1%
R67	321-0339-00	33.2 k	$\frac{1}{8}$ w	Prec	1%
R68	315-0183-00	18 k	$\frac{1}{4}$ w		5%
R69	315-0183-00	18 k	$\frac{1}{4}$ w		5%
R70	321-0342-00	35.7 k	$\frac{1}{8}$ w	Prec	1%
R72	315-0472-00	4.7 k	$\frac{1}{4}$ w		5%
R74	315-0101-00	100 $\Omega$	$\frac{1}{4}$ w		5%
R76	315-0750-00	75 $\Omega$	$\frac{1}{4}$ w		5%
R80	315-0510-00	51 $\Omega$	$\frac{1}{4}$ w		5%
R82	315-0471-00	470 $\Omega$	$\frac{1}{4}$ w		5%
R83	315-0100-00	10 $\Omega$	$\frac{1}{4}$ w		5%
R84	315-0390-00	39 $\Omega$	$\frac{1}{4}$ w		5%
R85	311-0323-00	1.5 k		Var	Snap-Off Current
R86	308-0299-00	300 $\Omega$	$\frac{3}{8}$ w	WW	1%
R87	315-0390-00	39 $\Omega$	$\frac{1}{4}$ w		5%
R88	315-0101-00	100 $\Omega$	$\frac{1}{4}$ w		5%
R89	315-0101-00	100 $\Omega$	$\frac{1}{4}$ w		5%
R92	315-0272-00	2.7 k	$\frac{1}{4}$ w		5%
R93	315-0100-00	10 $\Omega$	$\frac{1}{4}$ w		5%
R95	311-0497-00	50 k	$\frac{1}{4}$ w	Var	Memory Gate Width
R96	315-0432-00	4.3 k	$\frac{1}{4}$ w		5%
R98	315-0102-00	1 k	$\frac{1}{4}$ w		5%
R99	315-0392-00	3.9 k	$\frac{1}{4}$ w		5%
R101	321-0307-00	15.4 k	$\frac{1}{8}$ w	Prec	1%
R103	321-0222-00	2 k	$\frac{1}{8}$ w	Prec	1%
R105	323-0353-00	46.4 k	$\frac{1}{2}$ w	Prec	1%

†Furnished as a unit with R254, and SW254.

Parts List—Type 151

Resistors (Cont'd)

Ckt. No.	Tektronix Part No.	Description	S/N Range
R107	321-0222-00	2 k	1%
R109	321-0170-00	576 Ω	1%
R110	311-0480-00	500 Ω	Memory Bal
R111	323-0353-00	46.4 k	1%
R114	308-0258-00	6 k	5%
R115	301-0472-00	4.7 k	5%
R118	323-0353-00	46.4 k	1%
R120	321-0339-00	33.2 k	1%
R124	304-0104-00	100 k	
R126	315-0101-00	100 Ω	5%
R128	315-0563-00	56 k	5%
R130	308-0313-00	20 k	1%
R133	315-0101-00	100 Ω	5%
R139	321-0685-00	30 k	1/2%
R140	321-0684-00	15 k	1/2%
R145A	321-0665-00	2.16 k	1/2%
R145B	321-0683-00	182.5 k	1/2%
R145C	321-0682-00	60.83 k	1/2%
R145D	321-0677-00	30.4 k	1/2%
R145E	321-0675-00	18.25 k	1/2%
R145F	321-0669-00	6.08 k	1/2%
R145G	321-0666-00	3.04 k	1/2%
R145H	321-0663-00	1.07 k	1/2%
R145K	321-0680-00	35.3 k	1/2%
R145L	321-0674-00	17.4 k	1/2%
R145N	321-0707-00	16.5 k	1/2%
R145P	321-0706-00	25.5 k	1/2%
R153	303-0433-00	43 k	5%
R157	315-0201-00	200 Ω	5%
R159†	311-0529-00	2.5 k	DC OFFSET ± 1 V
R165	*311-0538-00	7 k	VARIABLE (mVolts/CM)
R167	301-0563-00	56 k	5%
R168	311-0329-00	50 k	VAR BAL
R170	321-0215-00	1.69 k	1%
R172	311-0449-00	1.5 k	VERT GAIN
R174	321-0286-00	9.31 k	1%
R175	315-0302-00	3 k	5%
R177	321-0328-00	25.5 k	1%
R180	323-0382-00	93.1 k	1%
R183	301-0303-00	30 k	5%
R185	315-0304-00	300 k	5%
R190	321-0434-00	324 k	1%
R192††	311-0529-00	2.5 k	VERT POSITION
R193	321-0392-00	118 k	1%
R194	311-0510-00	10 k	Position Range

†Furnished as a unit with R192.

††Furnished as a unit with R159.

## Resistors (Cont'd)

Ckt. No.	Tektronix Part No.		Description		S/N Range
R197	315-0101-00	100 $\Omega$	$\frac{1}{4}$ w		5%
R199	301-0303-00	30 k	$\frac{1}{2}$ w		5%
R203	316-0106-00	10 meg	$\frac{1}{4}$ w		
R205	315-0103-00	10 k	$\frac{1}{4}$ w		5%
R208	321-0267-00	5.9 k	$\frac{1}{8}$ w	Prec	1%
R210	315-0303-00	30 k	$\frac{1}{4}$ w		5%
R212	315-0101-00	100 $\Omega$	$\frac{1}{4}$ w		5%
R215	321-0267-00	5.9 k	$\frac{1}{8}$ w	Prec	1%
R220	315-0103-00	10 k	$\frac{1}{4}$ w		5%
R225	315-0272-00	2.7 k	$\frac{1}{4}$ w		5%
R228	315-0154-00	150 k	$\frac{1}{4}$ w		5%
R230	315-0102-00	1 k	$\frac{1}{4}$ w		5%
R232	315-0101-00	100 $\Omega$	$\frac{1}{4}$ w		5%
R235	315-0154-00	150 k	$\frac{1}{4}$ w		5%
R237	315-0123-00	12 k	$\frac{1}{4}$ w		5%
R240	315-0333-00	33 k	$\frac{1}{4}$ w		5%
R244	315-0272-00	2.7 k	$\frac{1}{4}$ w		5%
R246	315-0822-00	8.2 k	$\frac{1}{4}$ w		5%
R247	315-0123-00	12 k	$\frac{1}{4}$ w		5%
R250	315-0510-00	51 $\Omega$	$\frac{1}{4}$ w		5%
R252	315-0101-00	100 $\Omega$	$\frac{1}{4}$ w		5%
R254†	311-0535-00	20 k		Var	SAMPLES/CM
R255	315-0221-00	220 $\Omega$	$\frac{1}{4}$ w		5%
R256	321-0226-00	2.21 k	$\frac{1}{8}$ w	Prec	1%
R258	315-0152-00	1.5 k	$\frac{1}{4}$ w		5%
R260	315-0183-00	18 k	$\frac{1}{4}$ w		5%
R262	315-0390-00	39 $\Omega$	$\frac{1}{4}$ w		5%
R264	315-0101-00	100 $\Omega$	$\frac{1}{4}$ w		5%
R266	315-0101-00	100 $\Omega$	$\frac{1}{4}$ w		5%
R268	315-0101-00	100 $\Omega$	$\frac{1}{4}$ w		5%
R269	315-0103-00	10 k	$\frac{1}{4}$ w		5%
R270	311-0462-00	1 k		Var	Staircase DC level
R274	306-0184-00	180 k	2 w		
R276	315-0103-00	10 k	$\frac{1}{4}$ w		5%
R280	321-0365-00	61.9 k	$\frac{1}{8}$ w	Prec	1%
R283	315-0101-00	100 $\Omega$	$\frac{1}{4}$ w		5%
R285	315-0103-00	10 k	$\frac{1}{4}$ w		5%
R286	315-0471-00	470 $\Omega$	$\frac{1}{4}$ w		5%
R287	301-0202-00	2 k	$\frac{1}{2}$ w		5%
R290	311-0480-00	500 $\Omega$		Var	Sweep Length
R292	321-0366-00	63.4 k	$\frac{1}{8}$ w		1%
R293	311-0531-00	100 k		Var	MANUAL PREC SCAN EXT HORIZ ATTEN
R295	321-0306-00	15 k	$\frac{1}{8}$ w		1%
R297	315-0511-00	510 $\Omega$	$\frac{1}{4}$ w		5%
R298	315-0101-00	100 $\Omega$	$\frac{1}{4}$ w		5%

†Furnished as a unit with R56, and SW254.



Parts List—Type 151

Resistors (Cont'd)

Ckt. No.	Tektronix Part No.		Description		S/N Range
R299	315-0101-00	100 Ω	1/4 w		5%
R305	315-0471-00	470 Ω	1/4 w		5%
R306	317-0750-00	75 Ω	1/8 w		5%
R308	315-0202-00	2 k	1/4 w		5%
R309	315-0163-00	16 k	1/4 w		5%
R310	315-0330-00	33 Ω	1/4 w		5%
R313	321-0265-00	5.62 k	1/8 w		1%
R320	311-0442-00	250 Ω		Var	Prec
R326A	315-0510-00	51 Ω	1/4 w		5%
R326B	315-0510-00	51 Ω	1/4 w		5%
R328	315-0101-00	100 Ω	1/4 w		5%
R330	315-0100-00	10 Ω	1/4 w		5%
R334	308-0361-00	14.5 k	3 w		1%
R335	311-0540-00	2.5 k		Var	WW
R338	321-0085-00	75 Ω	1/8 w		Prec
R342	317-0391-00	390 Ω	1/8 w		5%
R344	315-0392-00	3.9 k	1/4 w		5%
R345	317-0200-00	20 Ω	1/8 w		5%
R350	315-0122-00	1.2 k	1/4 w		5%
R352	315-0152-00	1.5 k	1/4 w		5%
R353	315-0332-00	3.3 k	1/4 w		5%
R354	315-0682-00	6.8 k	1/4 w		5%
R356	315-0102-00	1 k	1/4 w		5%
R357	315-0101-00	100 Ω	1/4 w		5%
R365A } R365B }	311-0530-00	5 k 50 k		Var	TIME POSITION FINE
R366	323-0407-00	169 k	1/2 w		Prec
R367	301-0165-00	1.6 meg	1/2 w		5%
R370	311-0465-00	100 k		Var	
R372	321-0401-00	147 k	1/8 w		Prec
R375	321-0363-00	59 k	1/8 w		Prec
R377	321-0261-00	5.11 k	1/8 w		Prec
R380	311-0442-00	250 Ω		Var	
R383	321-0297-00	12.1 k	1/8 w		Prec
R385	315-0393-00	39 k	1/4 w		5%
R389	305-0273-00	27 k	2 w		5%
R391	315-0271-00	270 Ω	1/4 w		5%
R397	315-0270-00	27 Ω	1/4 w		5%
R399	315-0270-00	27 Ω	1/4 w		5%
R401	315-0101-00	100 Ω	1/4 w		5%
R402	315-0101-00	100 Ω	1/4 w		5%
R405	315-0101-00	100 Ω	1/4 w		5%
R406	315-0101-00	100 Ω	1/4 w		5%
R412	315-0101-00	100 Ω	1/4 w		5%
R413	315-0101-00	100 Ω	1/4 w		5%
R415	317-0390-00	39 Ω	1/8 w		5%

## Resistors (Cont'd)

Ckt. No.	Tektronix Part No.		Description			S/N Range
R418	322-0218-00	1.82 k	1/4 w		Prec	1%
R420	311-0496-00	2.5 k		Var		Int Trig Level
R423	321-0261-00	5.11 k	1/8 w		Prec	1%
R424	321-0204-00	1.3 k	1/8 w		Prec	1%
R428	317-0390-00	39 Ω	1/8 w			5%
R435†	311-0528-00	10 k		Var		TRIGGER SENSITIVITY
R437	322-0239-00	3.01 k	1/4 w		Prec	1%
R440	321-0210-00	1.5 k	1/8 w		Prec	1%
R444	317-0510-00	51 Ω	1/8 w			5%
R446	317-0101-00	100 Ω	1/8 w			5%
R448	315-0510-00	51 Ω	1/4 w			5%
R449	315-0390-00	39 Ω	1/4 w			5%
R450	315-0751-00	750 Ω	1/4 w			5%
R454	315-0330-00	33 Ω	1/4 w			5%
R456	315-0222-00	2.2 k	1/4 w			5%
R458	315-0102-00	1 k	1/4 w			5%
R460	311-0462-00	1 k		Var		Control TD Bias
R461	315-0751-00	750 Ω	1/4 w			5%
R464	307-0103-00	2.7 Ω	1/4 w			5%
R470	315-0102-00	1 k	1/4 w			5%
R473	301-0823-00	82 k	1/2 w			5%
R475††	311-0528-00	50 k		Var		Recovery Time
R478	316-0825-00	8.2 meg	1/4 w			
R480	316-0475-00	4.7 meg	1/4 w			
R483	323-0339-00	33.2 k	1/2 w		Prec	1%
R487	315-0102-00	1 k	1/4 w			5%
R489	315-0391-00	390 Ω	1/4 w			5%
R493	315-0123-00	12 k	1/4 w			5%
R495	321-0281-00	8.25 k	1/8 w		Prec	1%
R497	322-0349-00	42.2 k	1/4 w		Prec	1%
R499	315-0271-00	270 Ω	1/4 w			5%
R500A	311-0527-00	2 k		Var		VARIABLE (Time/CM)
R500B	321-0193-00	1 k	1/8 w		Prec	1%
R510A	321-0678-00	33.9 k	1/8 w		Prec	1/2%
R510B	321-0664-00	1.56 k	1/8 w		Prec	1/2%
R510C	321-0667-00	3.77 k	1/8 w		Prec	1/2%
R520A	321-0681-00	37.3 k	1/8 w		Prec	1/2%
R520B	321-0668-00	4.63 k	1/8 w		Prec	1/2%
R520C	321-0662-00	377 Ω	1/8 w		Prec	1/2%
R530A	321-0670-00	6.81 k	1/8 w		Prec	1/2%
R530B	321-0673-00	17 k	1/8 w		Prec	1/2%
R530C	321-0679-00	34 k	1/8 w		Prec	1/2%
R530E	321-0672-00	11.4 k	1/8 w		Prec	1/2%
R530F	321-0671-00	8.51 k	1/8 w		Prec	1/2%
R601	302-0393-00	39 k	1/2 w			

†Furnished as a unit with R475 and SW475.

††Furnished as a unit with R435 and SW475.

**Parts List—Type 151**

**Resistors (Cont'd)**

Ckt. No.	Tektronix Part No.		Description		S/N Range
R603	308-0082-00	3 k	5 w	WW	5%
R604	308-0003-00	2 k	5 w	WW	5%
R606	308-0209-00	100 Ω	5 w	WW	5%
R607	308-0223-00	35 Ω	3 w	WW	5%
R610	308-0075-00	100 Ω	3 w	WW	
R614	315-0333-00	33 k	1/4 w		5%
R616	315-0472-00	4.7 k	1/4 w		5%
R620	315-0203-00	20 k	1/4 w		5%
R623	323-0216-00	1.74 k	1/2 w	Prec	1%
R625	311-0433-00	100 Ω		Var	+19 v Cal
R626	323-0216-00	1.74 k	1/2 w	Prec	1%
R630	307-0103-00	2.7 Ω	1/4 w		5%
R632	307-0103-00	2.7 Ω	1/4 w		5%
R634	321-0277-00	7.5 k	1/8 w	Prec	1%
R640	308-0353-00	35 Ω	5 w	WW	5%
R645	308-0313-00	20 k	3 w	WW	1%
R650	315-0183-00	18 k	1/4 w		5%
R653	315-0103-00	10 k	1/4 w		5%
R656	323-0149-00	348 Ω	1/2 w	Prec	1%
R657	323-0195-00	1.05 k	1/2 w	Prec	1%
R658	311-0442-00	250 Ω		Var	-19 v Cal
R660	308-0267-00	7.5 k	5 w	WW	5%
R662	323-0122-00	182 Ω	1/2 w	Prec	1%

**Switches**

	Unwired	Wired		
SW60	260-0686-00	*262-0720-00	Rotary	mVOLTS/CM
SW203	260-0689-00		Push Button	START
SW215	260-0687-00	*262-0718-00	Rotary	DISPLAY MODE
SW254†	311-0535-00			SWEEP OFF
SW400	260-0685-00	*262-0719-00	Rotary	TRIGGER SOURCE
SW475††	311-0528-00			SYNC
SW500A } SW500B }	260-0684-00	*262-0721-00	Rotary	TIME POSITION RANGE TIME/CM

**Transformers**

T1	*120-0283-00	Toroid	7T bifilar
T80	*120-0286-00	Toroid	2T bifilar
T82	*120-0241-00	Toroid	2T-3T-4T
T88	*120-0403-00	Toroid	5T bifilar
T110	*120-0401-00	Toroid	20T

†Furnished as a unit with R56 and R254.

††Furnished as a unit with R435 and R475.

## Transformers (Cont'd)

Ckt. No.	Tektronix Part No.		Description	S/N Range
T340	*120-0374-00	Toroid	2T-4T	
T410	*120-0399-00	Toroid	8T	
T630	*120-0400-00	Power		

## Electron Tubes

V44	154-0413-00	8416	
V183	154-0413-00	8416	
V263	154-0417-00	8056	

## VOLTAGE AND WAVEFORM TEST CONDITIONS

Typical voltage measurements and waveform photographs (shown in blue) were obtained under the following conditions unless noted otherwise on the individual diagrams:

### Test Oscilloscope:

Bandpass	Dc to 30 Mc
Probe Input Impedance	10 Megohms, 7 picofarads
Probe Ground	Clipped to Type 1S1 chassis
Triggering	External from point indicated on diagram

### Dc Voltmeter:

Type	Volt-Ohmmeter
Sensitivity	20,000 ohms/volt

### Type 1S1 Conditions:

Installation	Connected to oscilloscope through 30-inch flexible extension
Vertical Input Signal	None
External Triggering Signal	None

### Type 1S1 Control Settings:





mVOLTS/CM	200
mVolts/Cm VARIABLE	CAL (at detent)
VERT POSITION	Centered
DC OFFSET	Zero volts at OFFSET OUTPUT
TIME/CM	50 nSEC
Time/Cm VARIABLE	CAL (at detent)
TIME POSITION RANGE	500 nS (locked to TIME/CM)
TIME POSITION	Centered
Time Position FINE	Centered
SMOOTHING	NORM (clockwise)
SAMPLES/CM	MIN (clockwise)
DISPLAY MODE	NORMAL
MANUAL SCAN	
EXT HORIZ ATTEN	Clockwise
TRIGGER SOURCE	INT +
TRIGGER SENSITIVITY	Clockwise
RECOVERY TIME	SYNC

(Continued on MEMORY  diagram)

Voltage readings are given in volts dc. Voltage measurements taken in any particular Type 1S1 may vary somewhat from those given, due to normal differences in component characteristics.

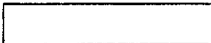
Waveform photographs were taken with a Tektronix Oscilloscope Camera System and Projected Graticule.

#### SCHEMATIC SYMBOLS

Front-panel title	 (around name)
Clockwise control rotation	
Screwdriver adjustment	
Electrical limit of etched-wiring board	 (blue line)
Solder connection to etched-wiring board	 (black dot)

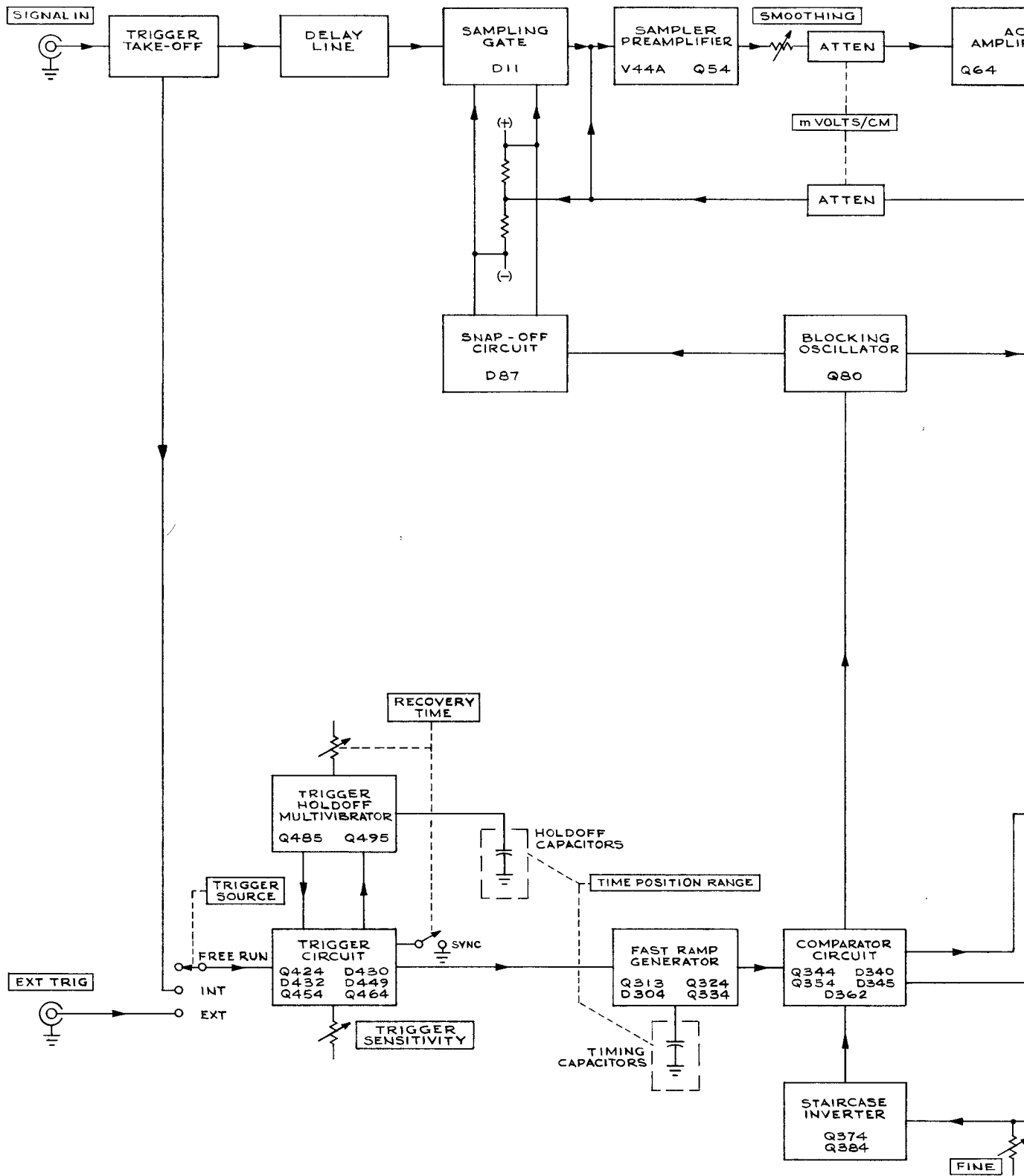

TYPE ISI SAMPLING UNIT

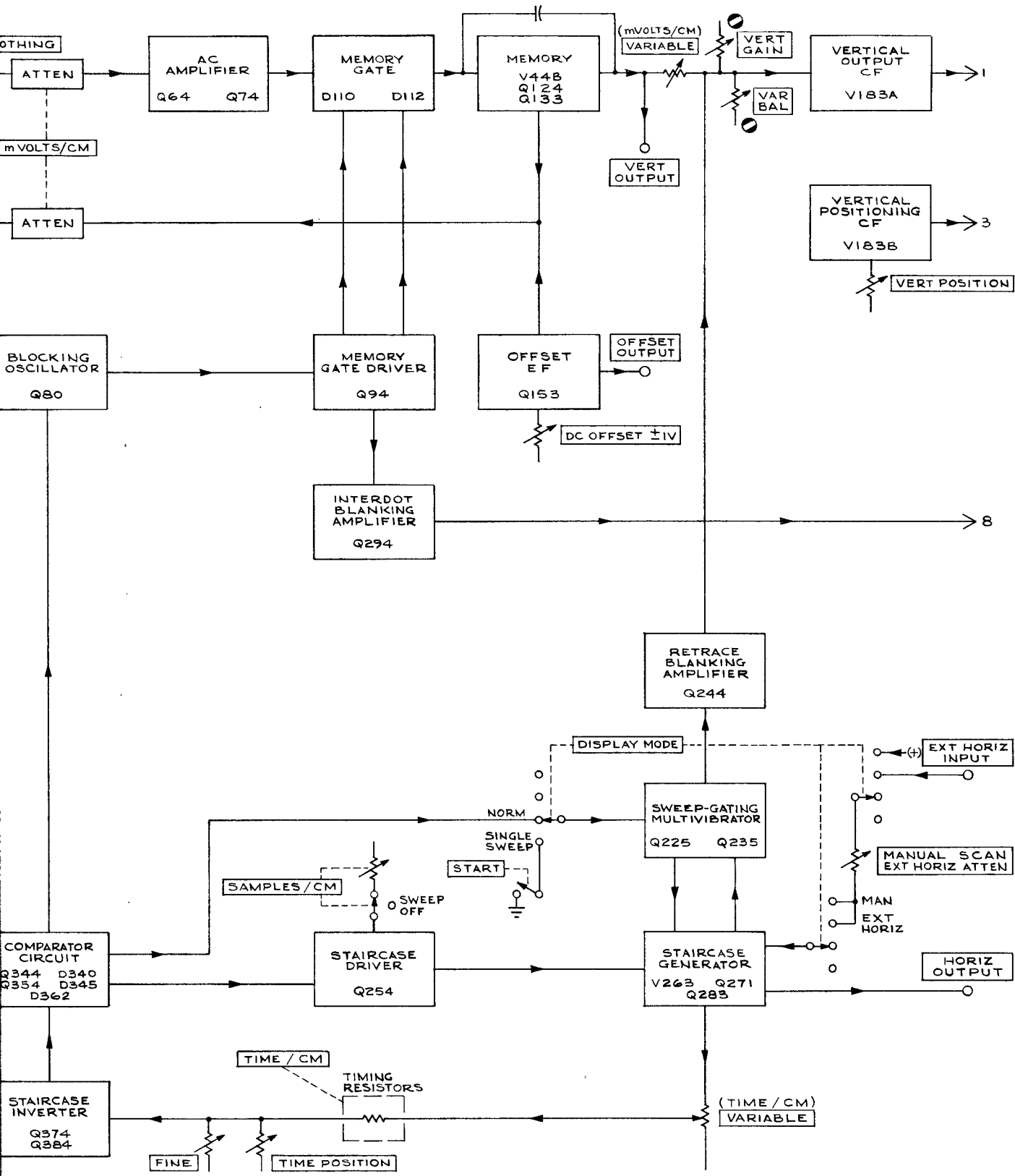

MRH  
565

BLOCK DIAGRAM

A



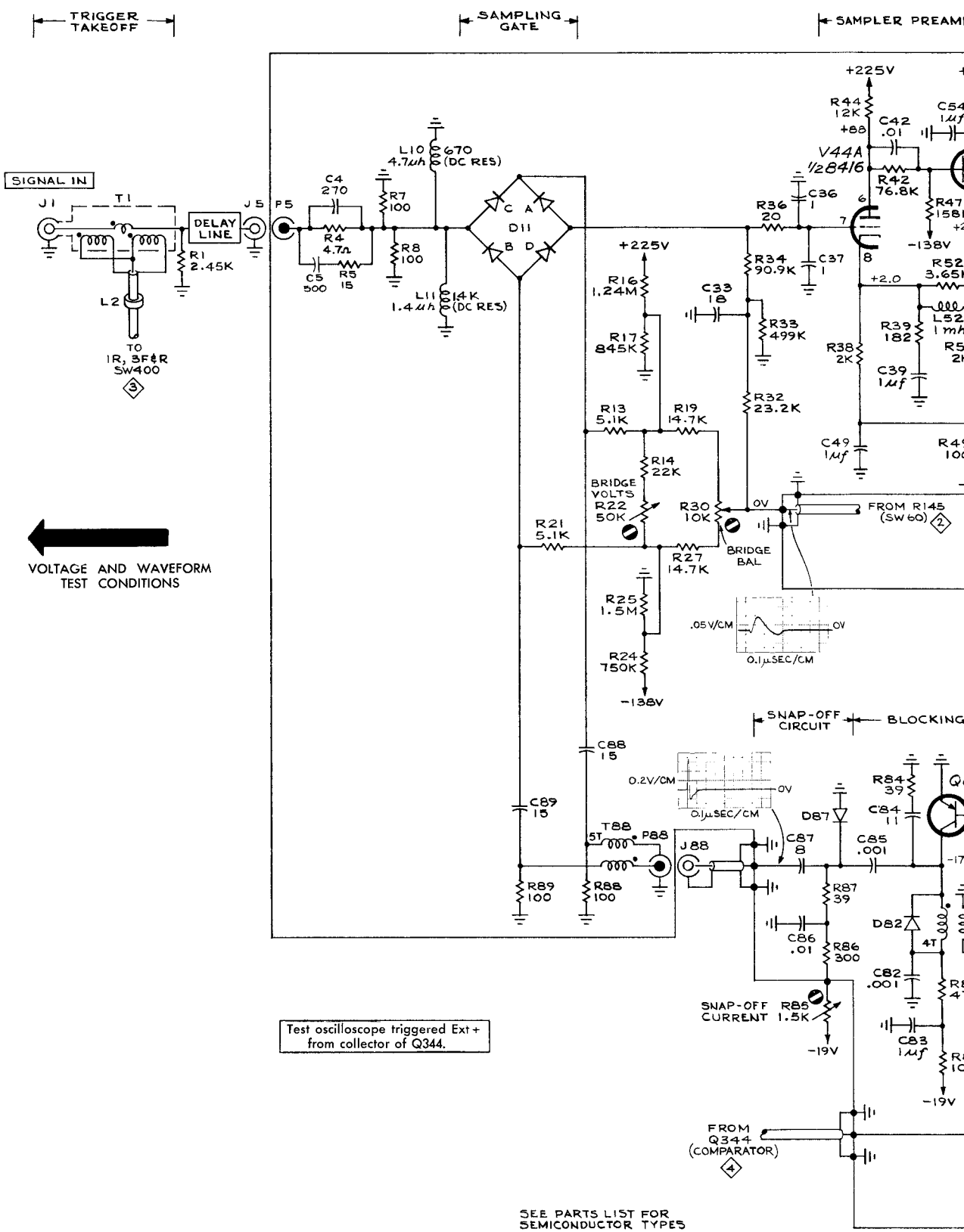

TYPE ISI SAMPLING UNIT

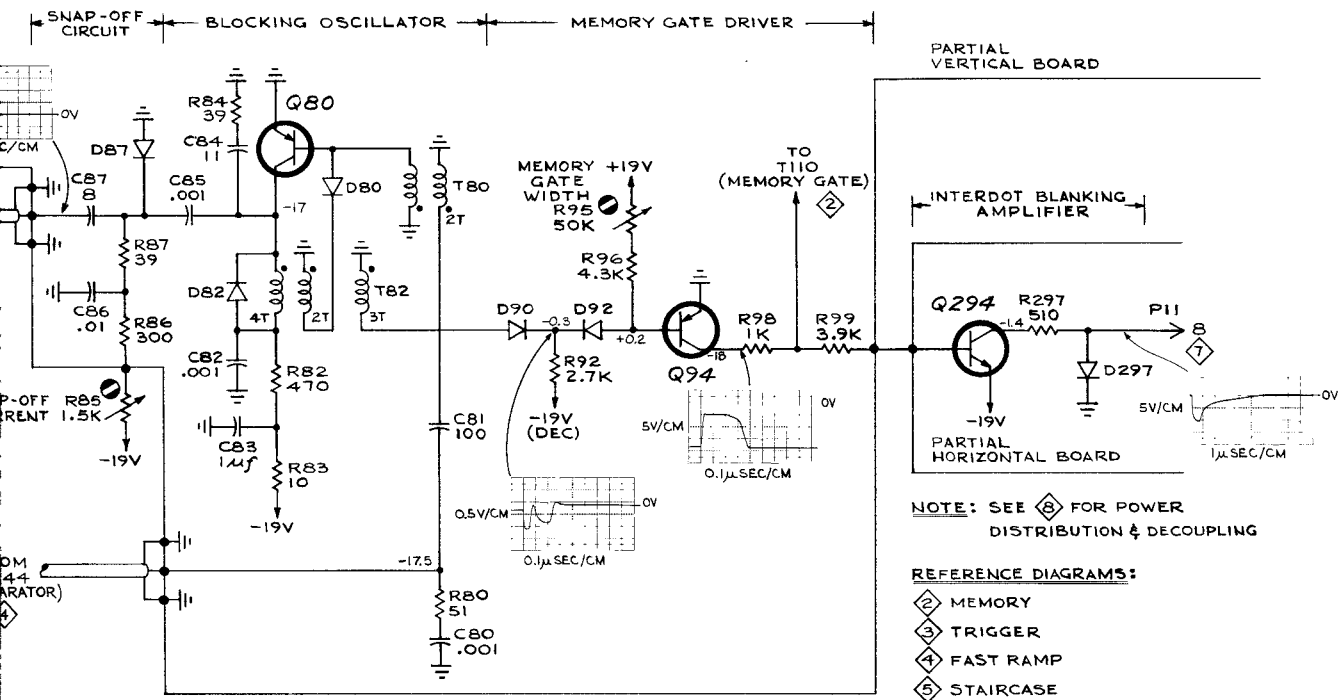
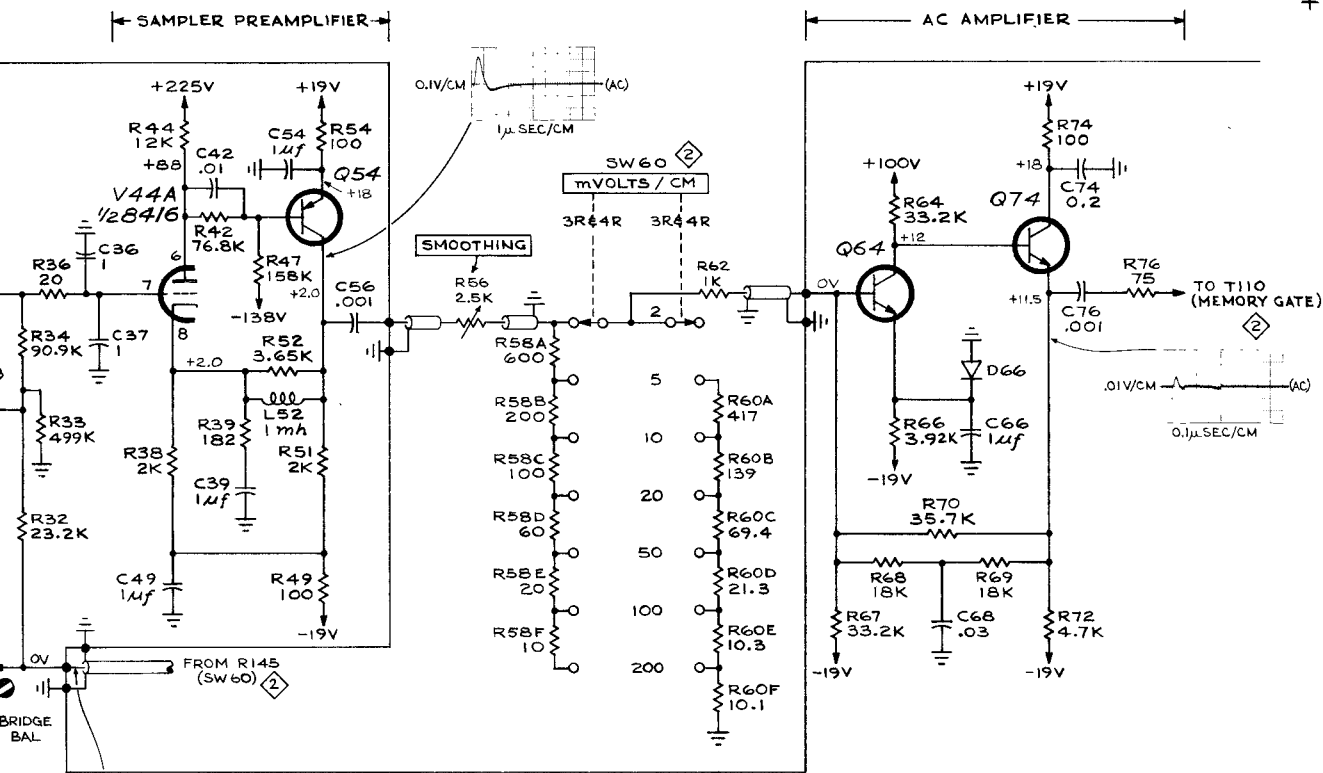

NOTE: SEE ⑧ FOR POWER DISTRIBUTION & DECOUPLING

**REFERENCE DIAGRAMS:**

- ② MEMORY
- ③ TRIGGER
- ④ FAST RAMP
- ⑤ STAIRCASE
- ⑦ POWER SUPPLY AND INTERCONNECTING PLUG

MRH  
465

SAMPLER ①

A

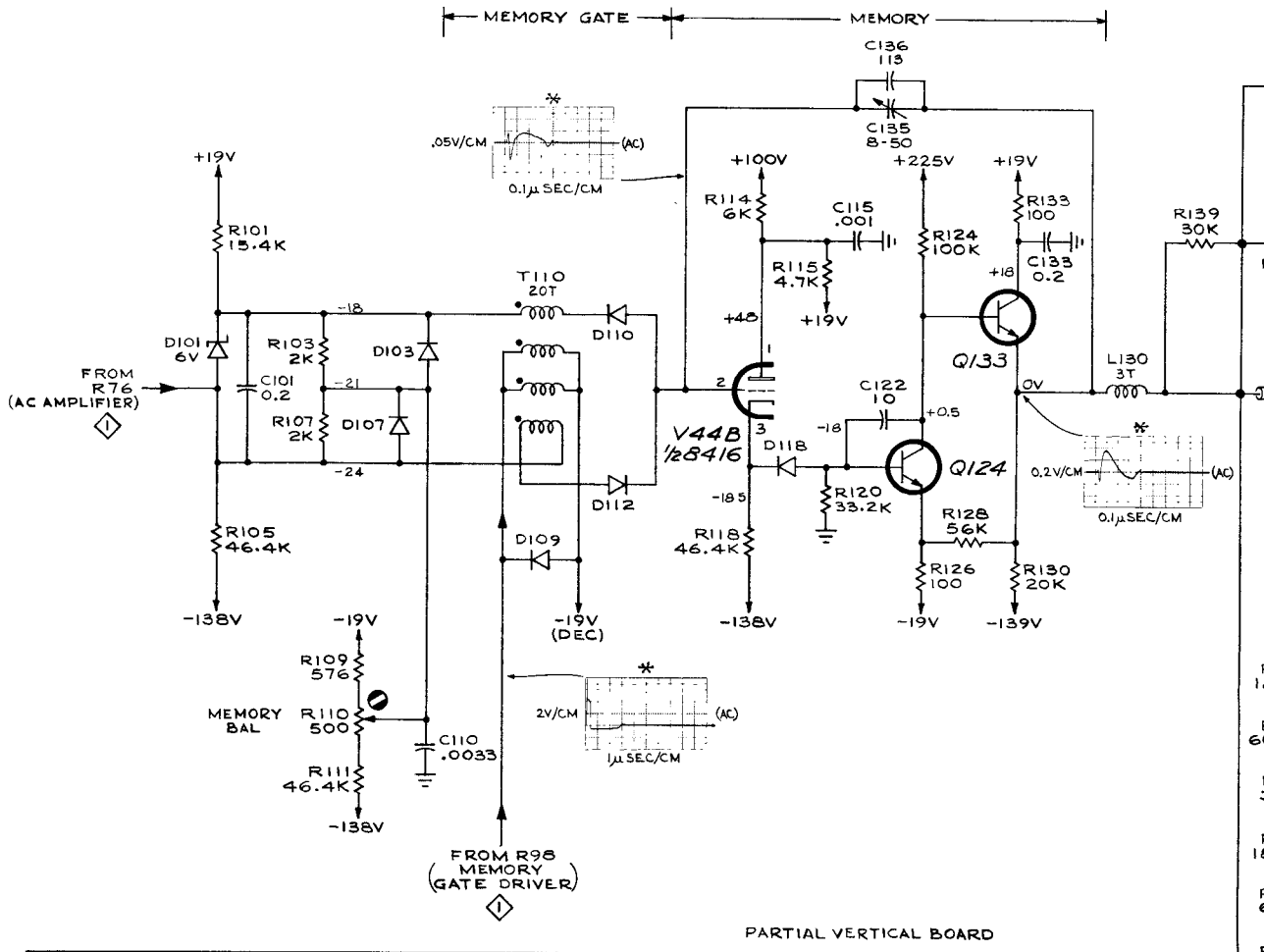

Test oscilloscope triggering:  
 \*Ext + from collector of Q344  
 \*\*Ext - from cathode of D285

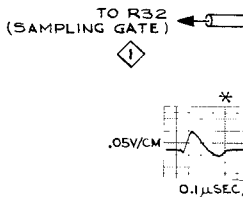

**NOTE:** SEE FOR POWER DISTRIBUTION & DECOUPLING

**REFERENCE DIAGRAMS:**

- SAMPLER
- STAIRCASE
- POWER SUPPLY & INTERCONNECTING PLUG

SEE PARTS LIST FOR SEMICONDUCTOR TYPES

TYPE ISI SAMPLING UNIT

A

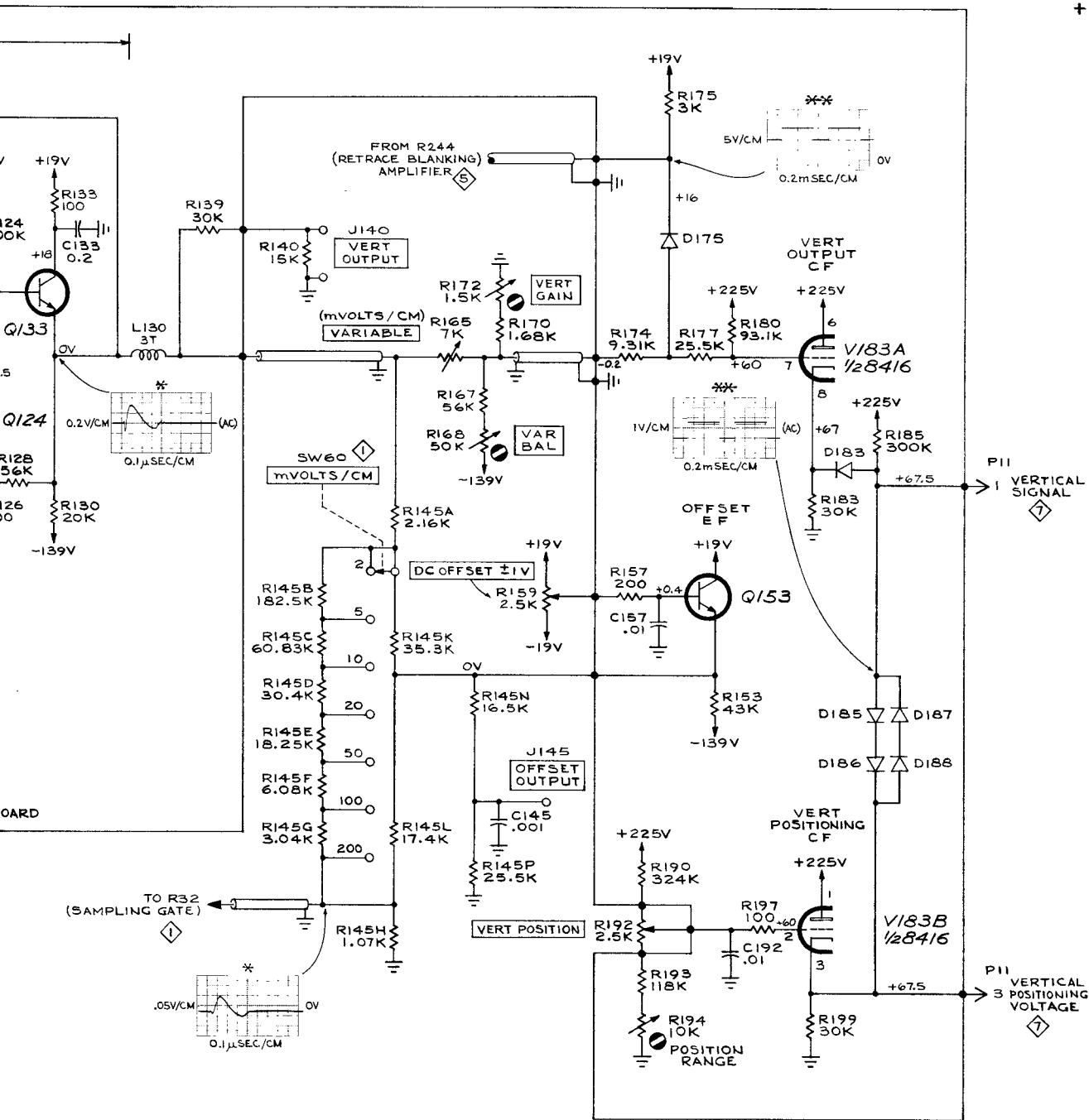

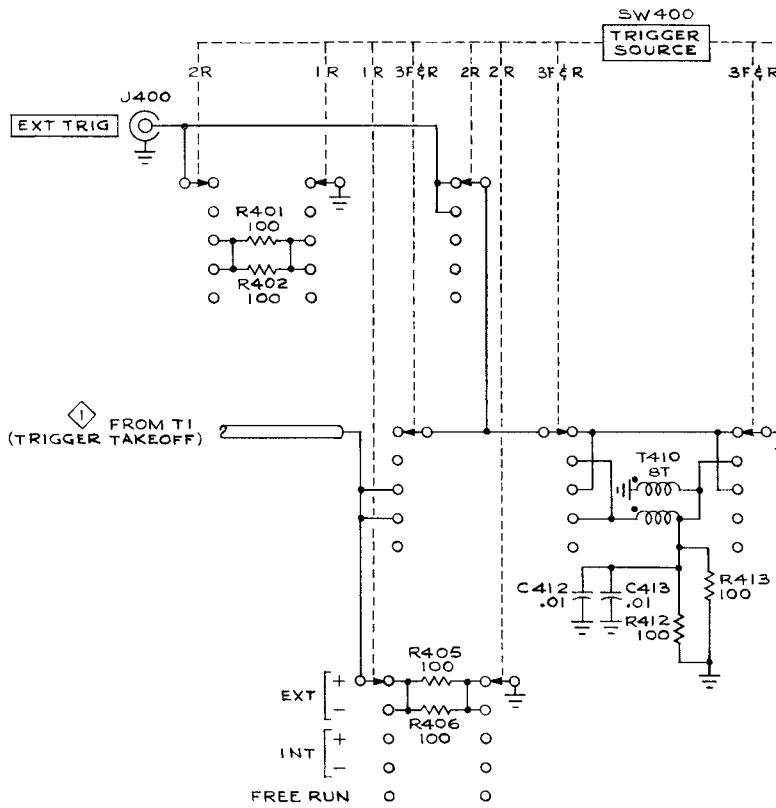

NOTE: SEE ⑧ FOR POWER DISTRIBUTION AND DECOUPLING

REFERENCE DIAGRAMS :

- ① SAMPLER
- ④ FAST RAMP
- ⑥ TIMING SWITCH

SEE PARTS LIST FOR SEMICONDUCTOR TYPES

TYPE ISI SAMPLING UNIT

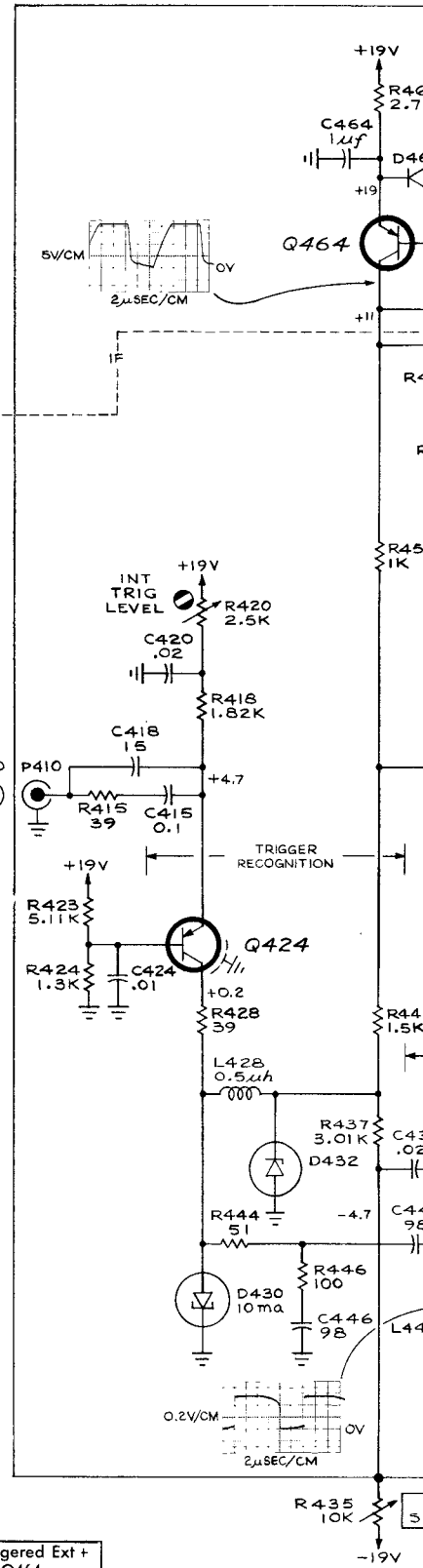

Test oscilloscope triggered Ext + from collector of Q464.

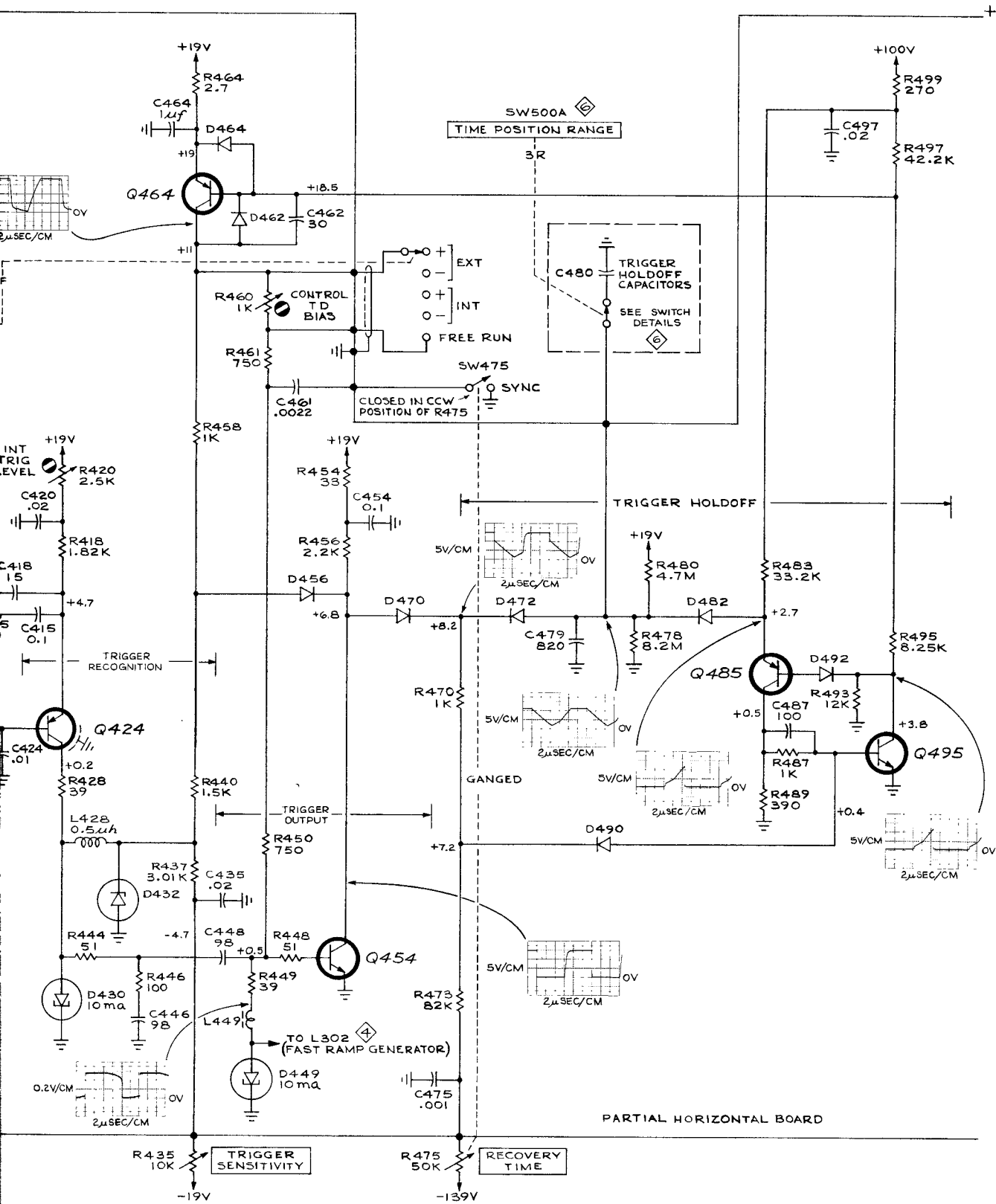

A

MRH  
465  
TRIGGER 3

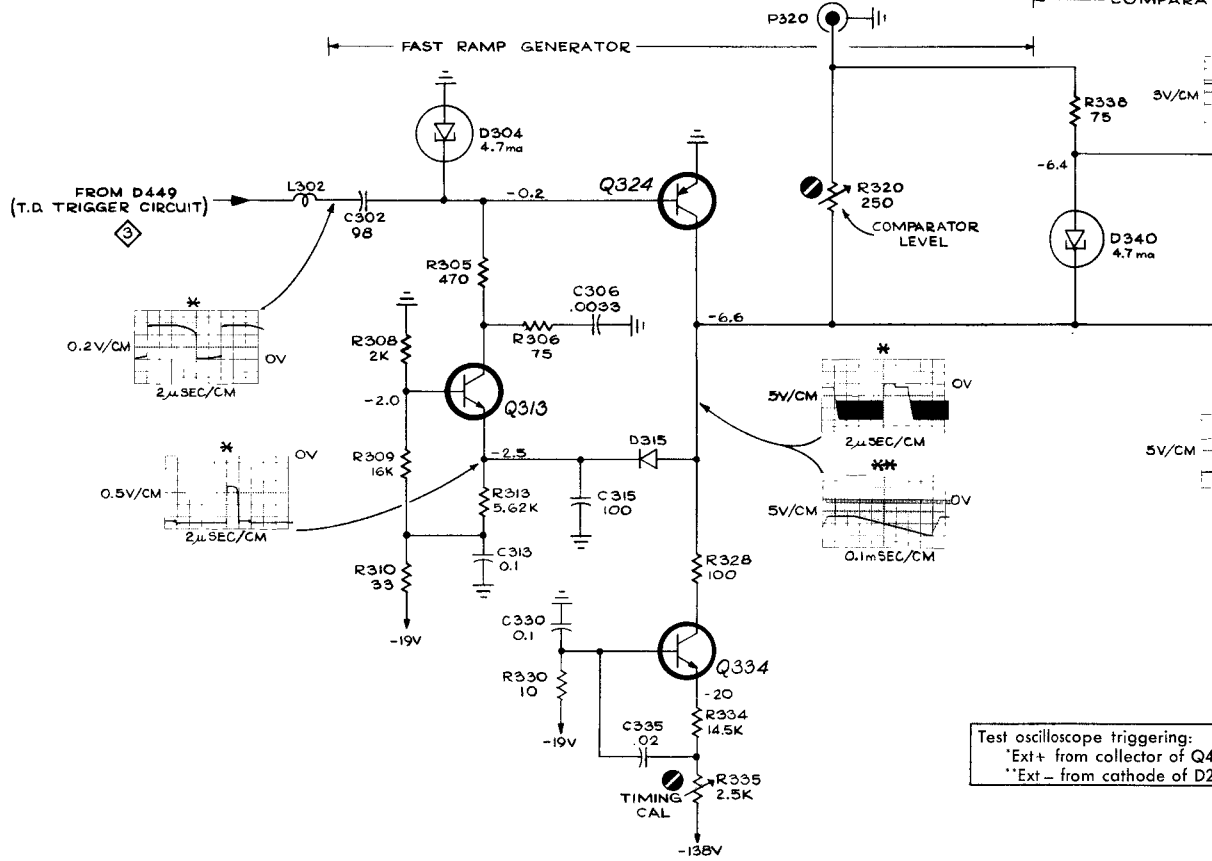
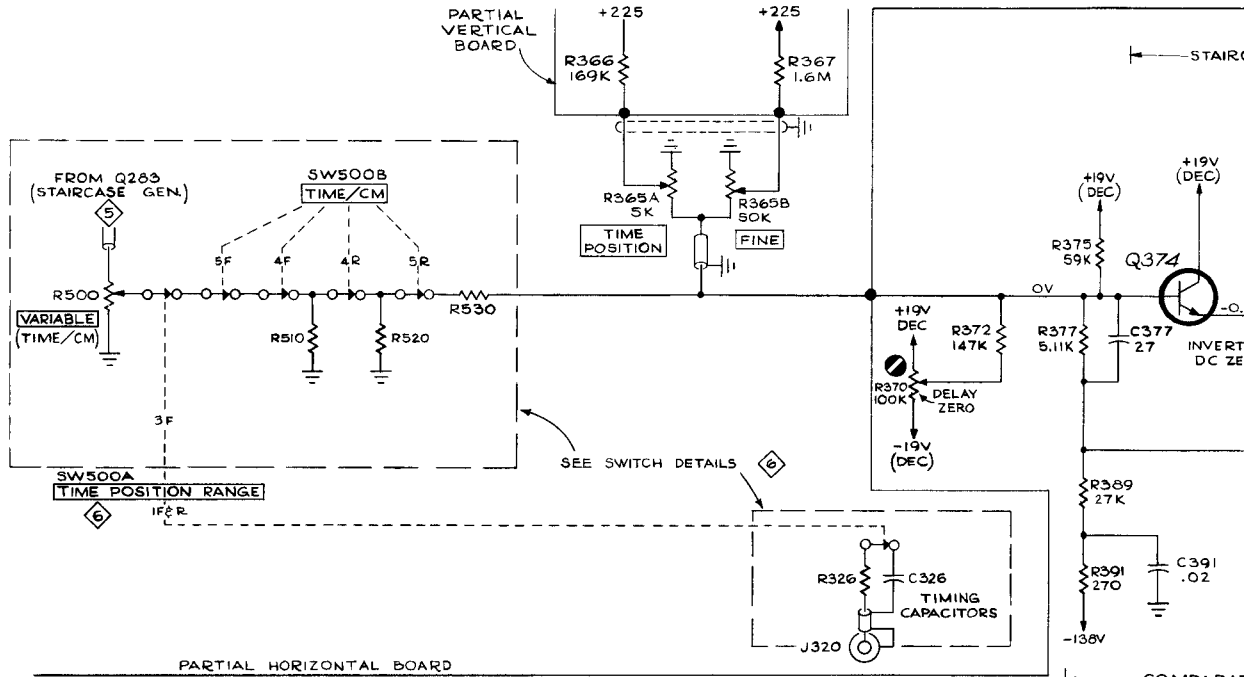

Test oscilloscope triggering:  
 \*Ext+ from collector of Q313  
 \*\*Ext- from cathode of D315

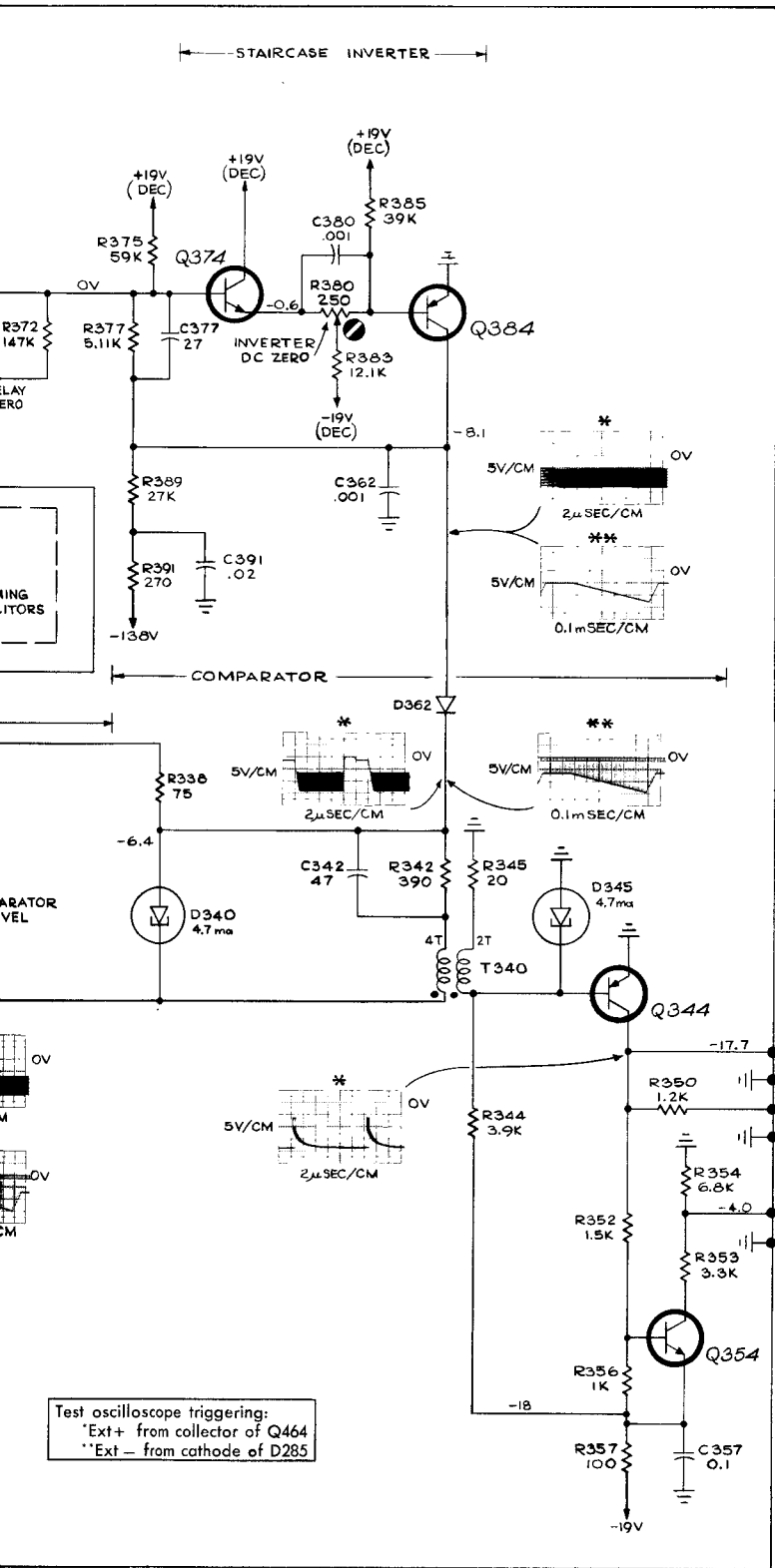

NOTE:  
SEE  $\diamond$  B FOR POWER DISTRIBUTION & DECOUPLING

SEE PARTS LIST FOR SEMICONDUCTOR TYPES

REFERENCE DIAGRAMS

- $\diamond$  1 SAMPLER
- $\diamond$  3 TRIGGER
- $\diamond$  5 STAIRCASE
- $\diamond$  6 TIMING SWITCH
- $\diamond$  8 POWER DISTRIBUTION

GTN  
465

FAST RAMP  $\diamond$  4



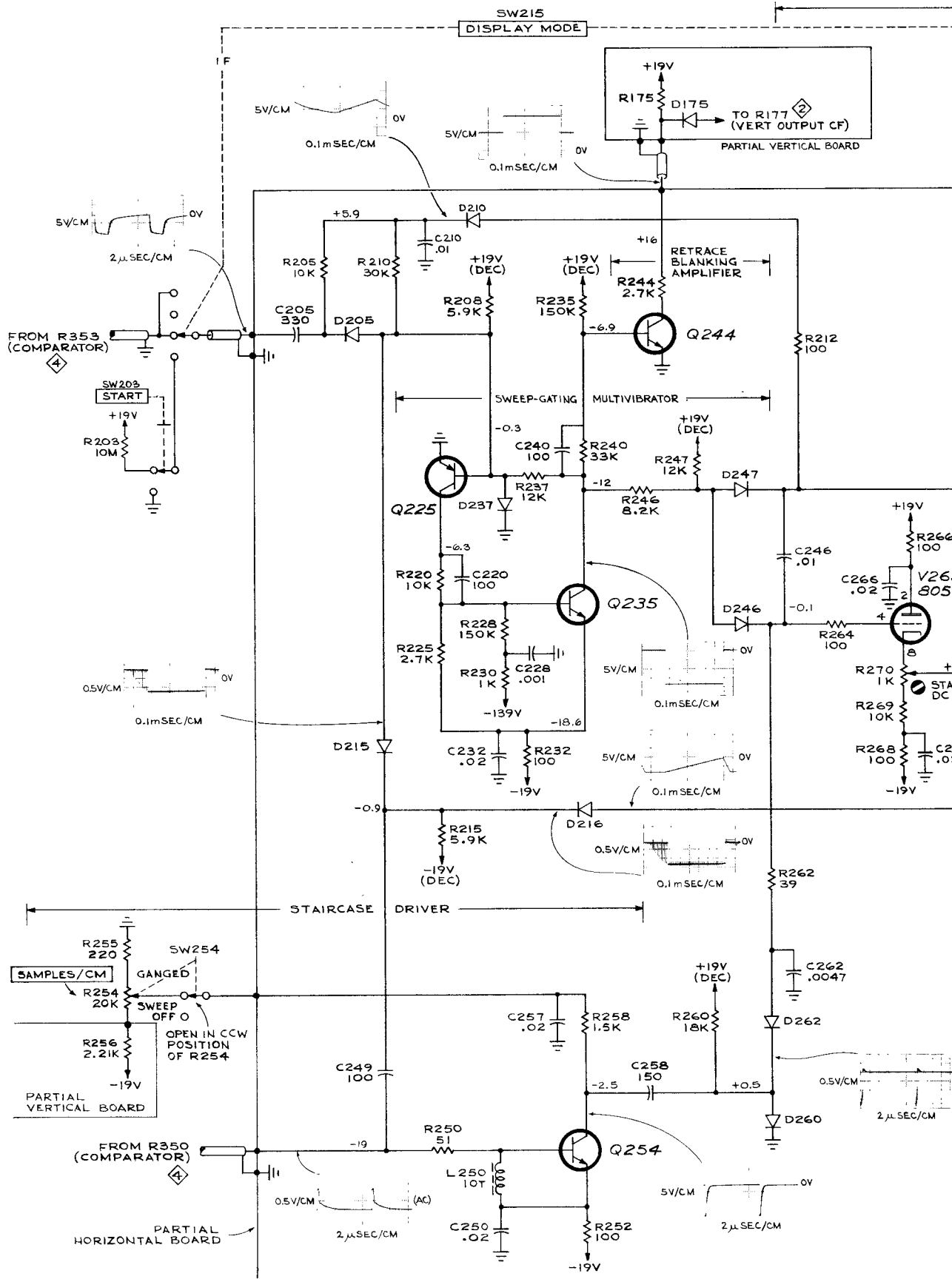

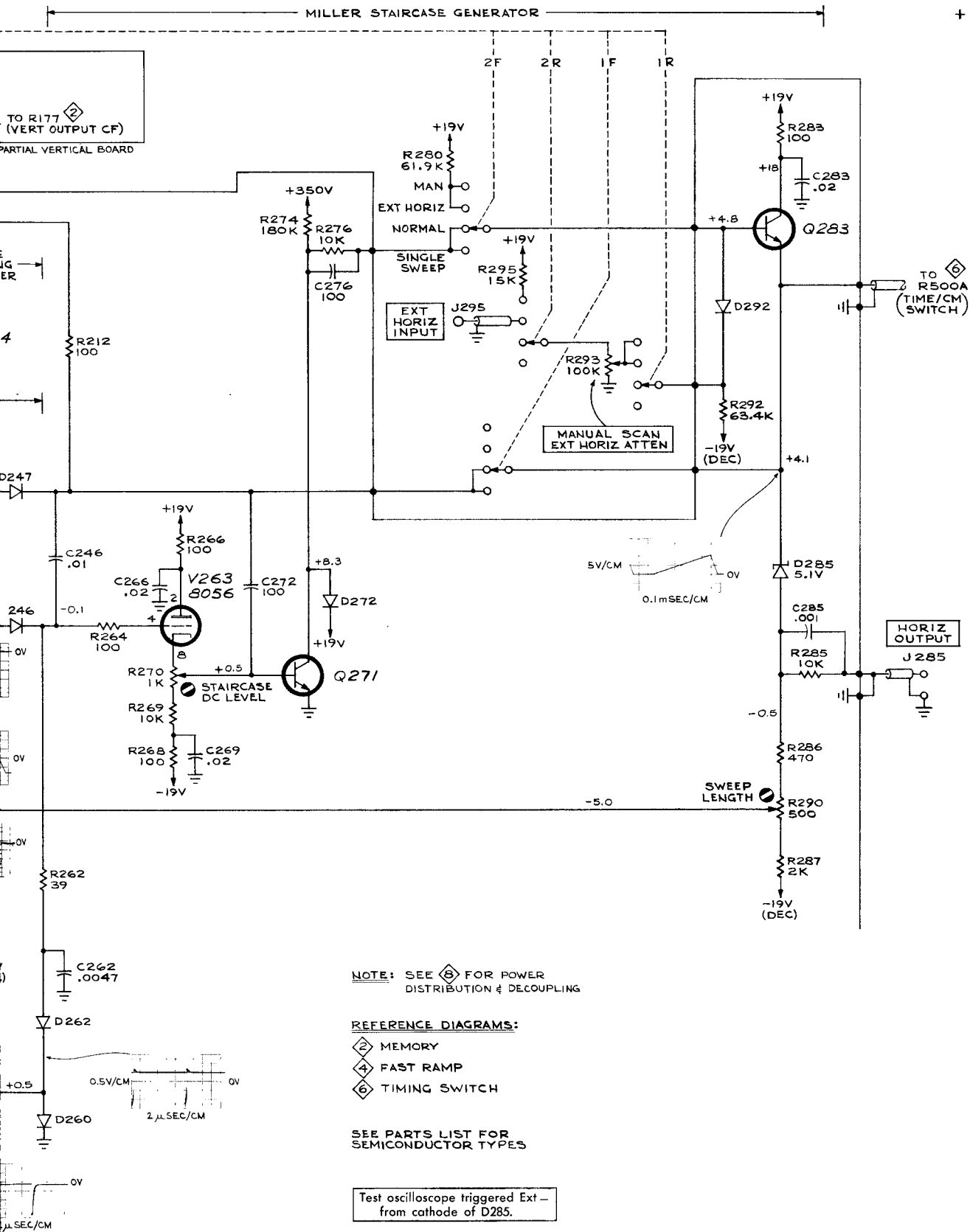

NOTE: SEE ⑤ FOR POWER DISTRIBUTION & DECOUPLING

REFERENCE DIAGRAMS:

- ② MEMORY
- ④ FAST RAMP
- ⑥ TIMING SWITCH

SEE PARTS LIST FOR SEMICONDUCTOR TYPES

Test oscilloscope triggered Ext - from cathode of D285.

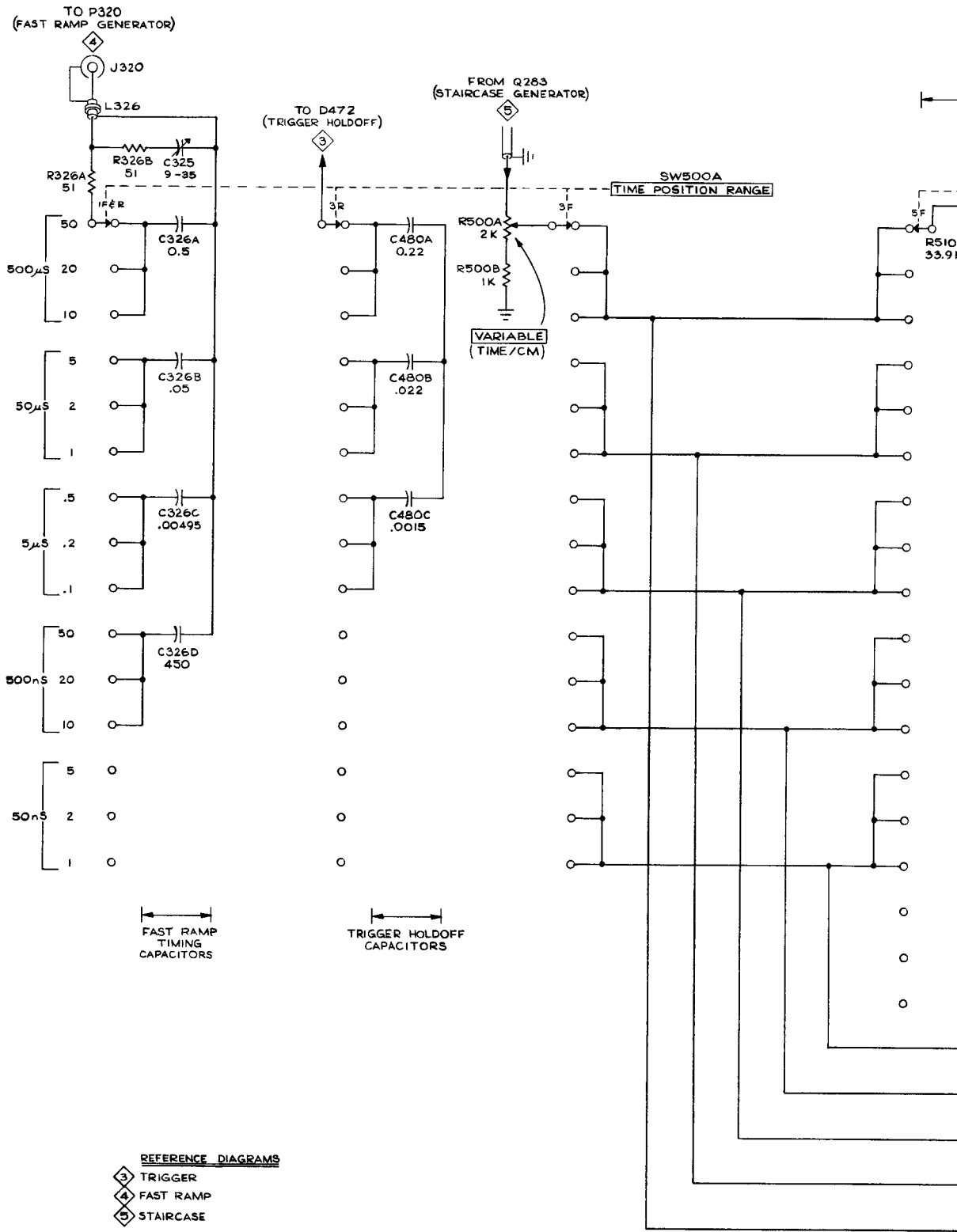

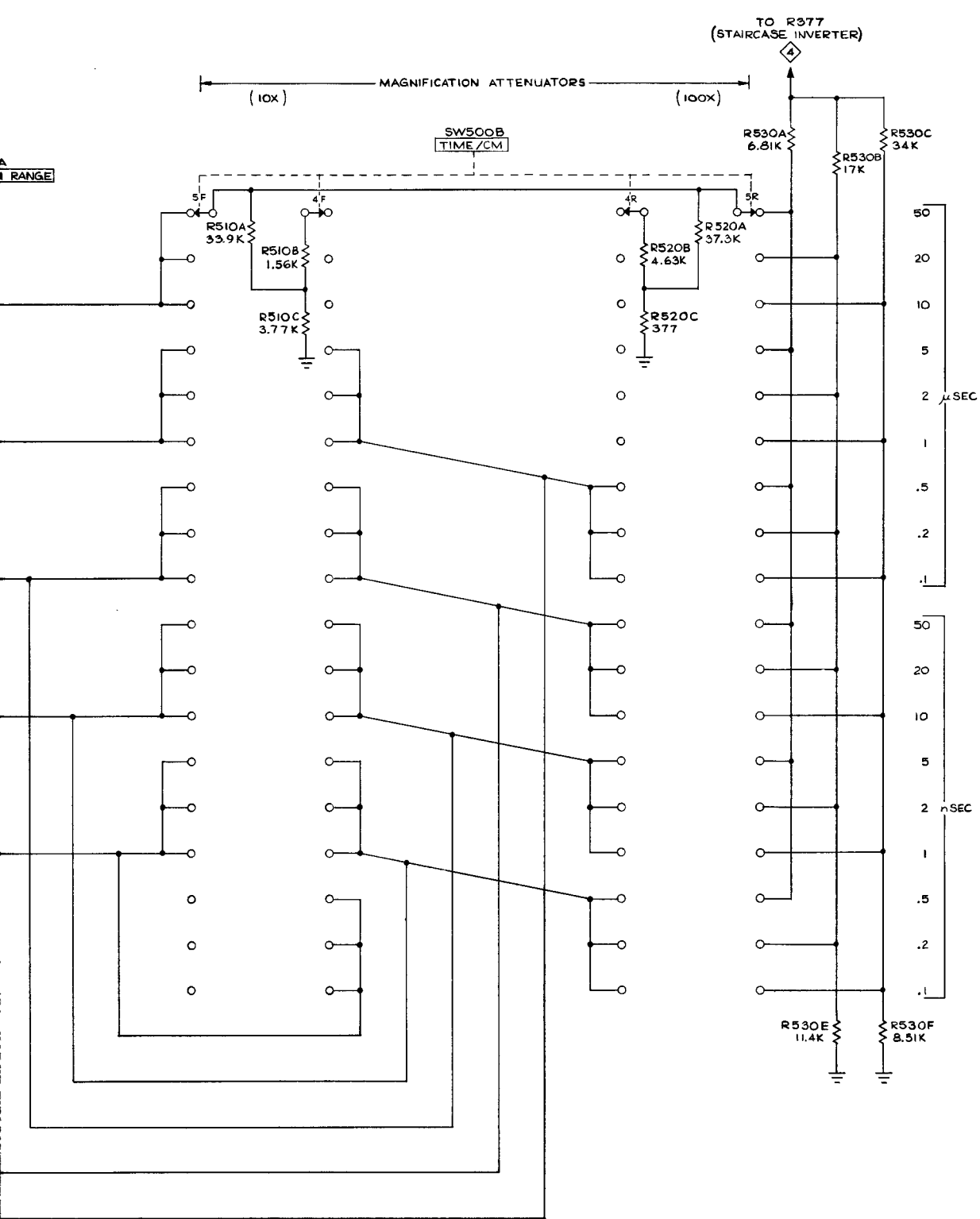

A

GTN  
465  
TIMING SWITCH ⑥



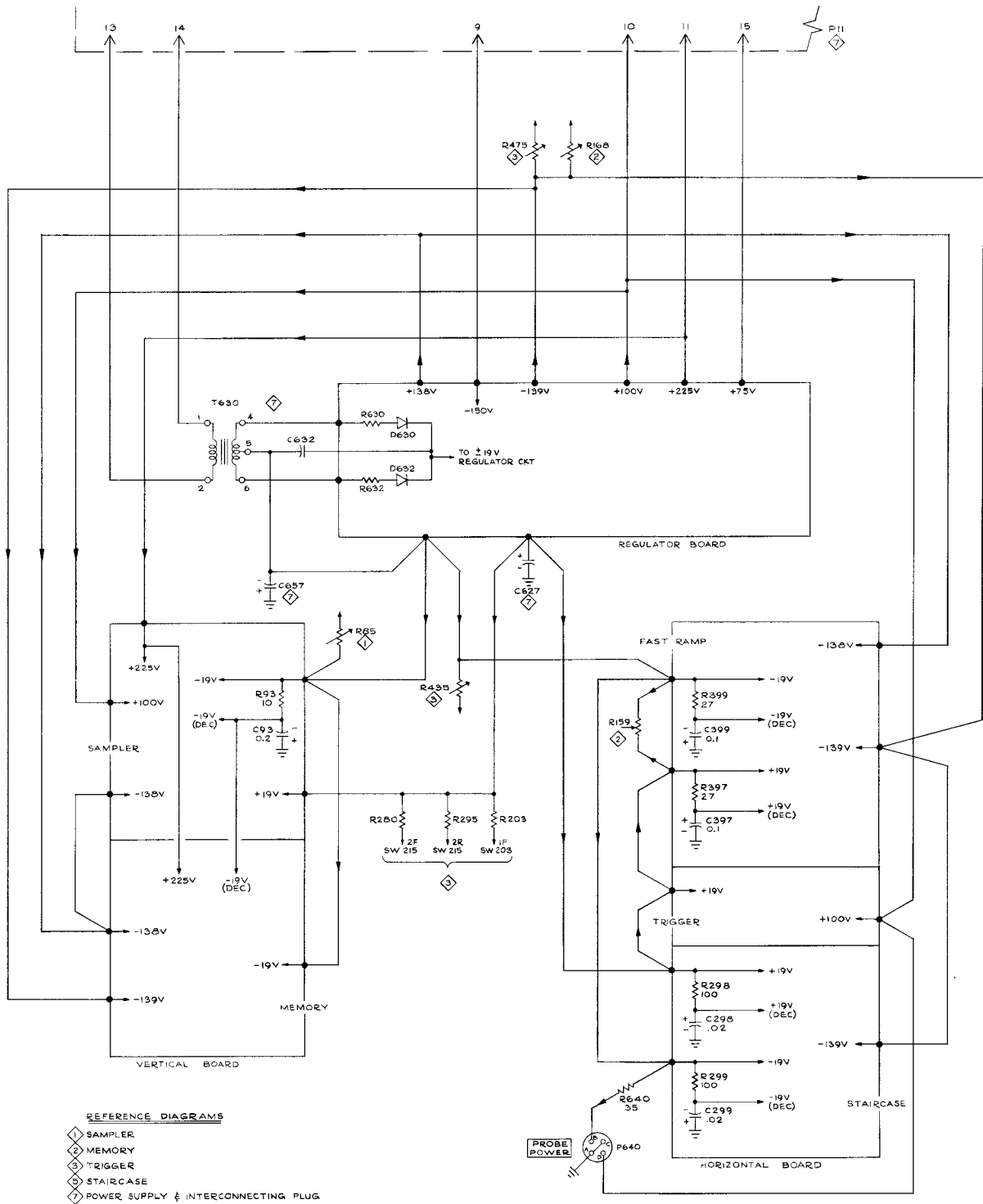

TYPE 1S1 SAMPLING UNIT

GTN 563  
POWER DISTRIBUTION

## **MANUAL CHANGE INFORMATION**

At Tektronix, we continually strive to keep up with latest electronic developments by adding circuit and component improvements to our instruments as soon as they are developed and tested.

Sometimes, due to printing and shipping requirements, we can't get these changes immediately into printed manuals. Hence, your manual may contain new change information on following pages. If it does not, your manual is correct as printed.

TYPE 1S1

PARTS LIST CORRECTION

CHANGE TO:

Q324 153-0532-00

2N1195 Checked



Type 1S1 Tent S/N 360

Parts List Correction

Change To:

D11, A, B, C & D<sup>1</sup>      153-0014-00      Diode      Checked

<sup>1</sup>Matched pairs of 152-0103-00

Type 1S1 Tent S/N 500

Parts List Correction

Change To:

Q667

151-0150-00

2N3440

Type 1S1 Tent S/N 500

Parts List Correction

Change To:

R76	Test Selected	Nominal Value	75 $\Omega$
-----	---------------	---------------	-------------